

## **Appendix 1 – Consultation on the proposed DCO Amendment**

**Appendix 2 – Photographs of Northampton Gateway SRFI**

**Appendix 3 – Latest site Illustrative masterplan (Ref. NGW-PHP-00-00-DR-A-4054-001-P27)**

**Appendix 4 – Draft DCO Amendment Order**

**Appendix 5 – Proposed revised Parameters Plan (Doc 2.10 Ref. 4054-R007 – Rev S4)**

**Appendix 6 – Transport Technical Note (by ADC Infrastructure)**

**Appendix 7 – Air Quality and Noise impacts Technical Note (by Vanguardia)**

## **Appendix 1 - Consultation**

The 2011 Regulations set out the process for publicising and consulting on non-material change applications. In summary, the 2011 Regulations initially require the Applicant to notify the Planning Inspectorate of its intention to submit an application and at the time of submission, to publicise the application, sending notices to relevant parties.

### **Duty to Consult (Regulation 7)**

The 2011 Regulations allow for a reduced schedule of consultees (i.e. those consulted at the time of the application submission) to be agreed with the Secretary of State. The Applicant has agreed a reduced list of consultees in relation to parties with an interest in the land because there were a number of parties who were previously consulted pursuant to section 56 of the Planning Act 2008 in 2018 who no longer hold an interest in the land. Those parties' interests have either been acquired by the Applicant for the development or for the delivery of highway land which is now adopted public highway.

Notices of the submission of the application were sent on 8<sup>th</sup> May 2025 to those consultees who were notified of the DCO application pursuant to section 56 of the Planning Act 2008, apart from:

- a) the reduced list of parties with an interest in the land as agreed with the Secretary of State as explained above;
- b) consultees who no longer exist;, or
- c) where the Applicant is aware of personnel changes, in which case notices are being sent to the known updated contact.

In addition to formally notifying the relevant consultees, the Applicant has also engaged with the following interested parties to give them advanced notice of the intention to submit the application:

- National Highways – using contacts secured during delivery of the project via specific dialogue regarding this proposed change starting in summer 2024;
- West Northamptonshire Council – the LPA and local highways authority through specific dialogue, specifically with regard to these changes starting in September 2024, and including an update briefing with Senior Officers in early April 2025;
- The Northampton Gateway Community Liaison Group (March 2025 meeting) including the following local Parish Council (PC) representatives, and via follow-up emailed letters in April 2025:
  - Blisworth PC

- Collingree PC;
  - Courteenhall Parish Meeting;
  - Grange Park PC;
  - Milton Malsor PC;
  - Roade PC
  - Stoke Bruerne PC
- The following wider Parish Councils who are not members of the Community Liaison Group, but are bodies which the Applicant was keen to engage with in advance of the application submission, to explain the proposals:
    - Wooton PC;
    - East Hunsbury PC
    - Rothersthorpe PC
    - Quinton PC
    - Gayton PC
- Other interested parties including, written to by email on 9<sup>th</sup> April 2025:
    - Mike Reader MP (Northampton South)
    - Sarah Bool MP (South Northamptonshire)

### **Statement of Consultation**

The above details of publicity and consultation have been provided to comply with the requirements of Regulation 7A of the 2011 Regulations and are intended as the Applicant's statement on the consultation undertaken for the non-material change application to the DCO.

**Appendix 2 – Photographs of Northampton Gateway SRFI**

# PROGRESS PHOTOS, March 2025



Plot 4 drone progress image, with rail terminal beyond

Plot 7 ground progress image





Rail track and terminal images



On-site roads, and other future plots (looking east towards A508)



**Appendix 3 – Latest site Illustrative masterplan (Ref. NGW-PHP-00-00-DR-A-4054-001-P27)**

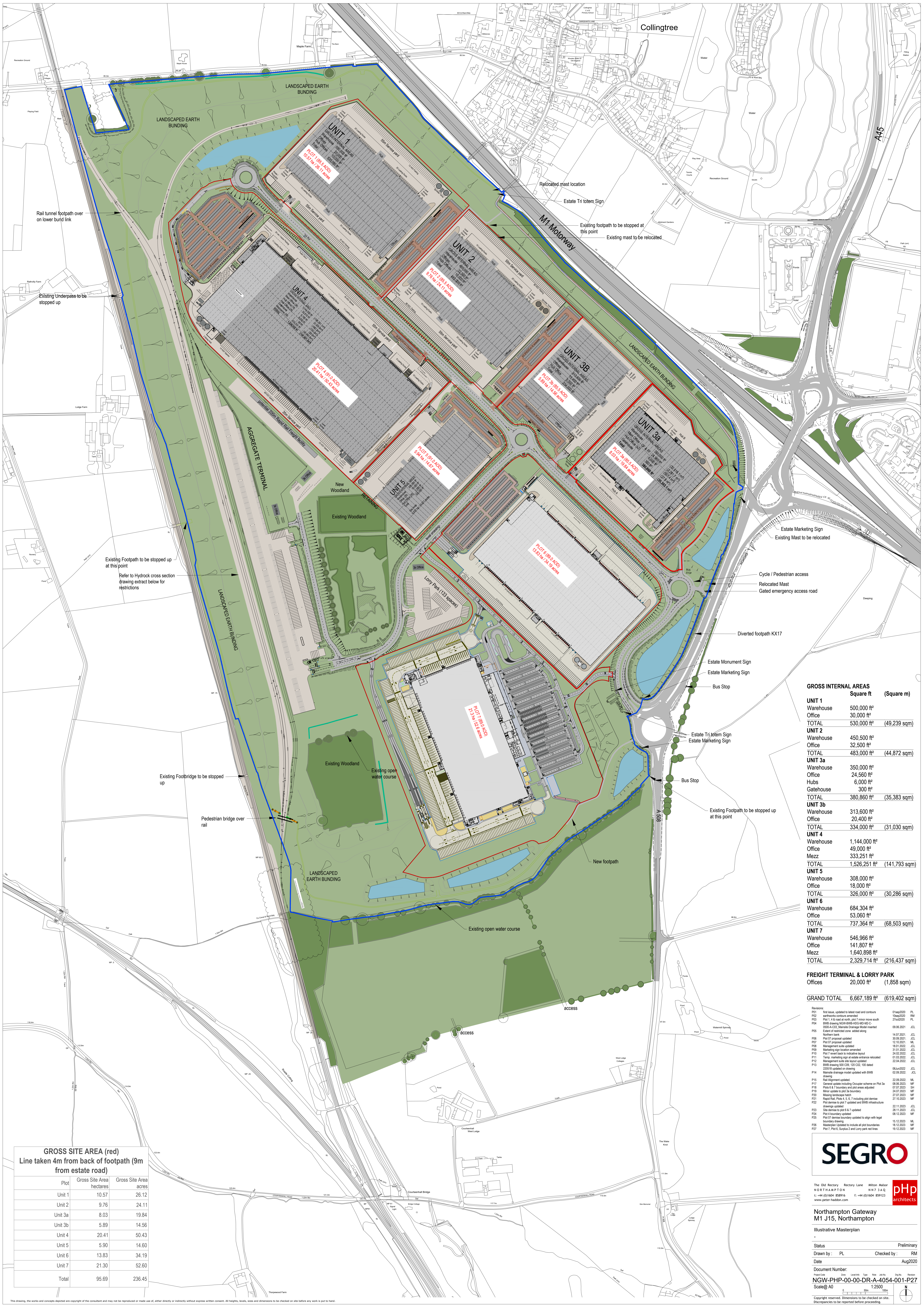

GROSS INTERNAL AREAS		
	Square ft	(Square m)
<b>UNIT 1</b>		
Warehouse	500,000 ft <sup>2</sup>	
Office	30,000 ft <sup>2</sup>	
<b>TOTAL</b>	<b>530,000 ft<sup>2</sup></b>	<b>(49,239 sqm)</b>
<b>UNIT 2</b>		
Warehouse	450,500 ft <sup>2</sup>	
Office	32,500 ft <sup>2</sup>	
<b>TOTAL</b>	<b>483,000 ft<sup>2</sup></b>	<b>(44,872 sqm)</b>
<b>UNIT 3a</b>		
Warehouse	350,000 ft <sup>2</sup>	
Office	24,560 ft <sup>2</sup>	
Hubs	6,000 ft <sup>2</sup>	
Gatehouse	300 ft <sup>2</sup>	
<b>TOTAL</b>	<b>380,860 ft<sup>2</sup></b>	<b>(35,383 sqm)</b>
<b>UNIT 3b</b>		
Warehouse	313,600 ft <sup>2</sup>	
Office	20,400 ft <sup>2</sup>	
<b>TOTAL</b>	<b>334,000 ft<sup>2</sup></b>	<b>(31,030 sqm)</b>
<b>UNIT 4</b>		
Warehouse	1,144,000 ft <sup>2</sup>	
Office	49,000 ft <sup>2</sup>	
Mezz	333,251 ft <sup>2</sup>	
<b>TOTAL</b>	<b>1,526,251 ft<sup>2</sup></b>	<b>(141,793 sqm)</b>
<b>UNIT 5</b>		
Warehouse	308,000 ft <sup>2</sup>	
Office	18,000 ft <sup>2</sup>	
<b>TOTAL</b>	<b>326,000 ft<sup>2</sup></b>	<b>(30,286 sqm)</b>
<b>UNIT 6</b>		
Warehouse	684,304 ft <sup>2</sup>	
Office	53,060 ft <sup>2</sup>	
<b>TOTAL</b>	<b>737,364 ft<sup>2</sup></b>	<b>(68,503 sqm)</b>
<b>UNIT 7</b>		
Warehouse	546,966 ft <sup>2</sup>	
Office	141,807 ft <sup>2</sup>	
Mezz	1,640,898 ft <sup>2</sup>	
<b>TOTAL</b>	<b>2,329,714 ft<sup>2</sup></b>	<b>(216,437 sqm)</b>
<b>FREIGHT TERMINAL &amp; LORRY PARK</b>		
Offices	20,000 ft <sup>2</sup>	(1,858 sqm)
<b>GRAND TOTAL</b>	<b>6,667,189 ft<sup>2</sup></b>	<b>(619,402 sqm)</b>

Revisions	Date	By
R001	07/04/2020	PL
R002	07/04/2020	RM
R003	27/04/2020	PL
R004	09/06/2020	JCL
R005	14/02/2021	JCL
R006	30/08/2021	JCL
R007	12/10/2021	ML
R008	18/01/2022	JCL
R009	31/01/2022	JCL
R010	24/02/2022	JCL
R011	01/03/2022	JCL
R012	22/04/2022	JCL
R013	05/04/2022	JCL
R014	02/08/2022	JCL
R015	22/09/2022	ML
R016	08/10/2022	MF
R017	07/07/2023	SH
R018	24/02/2023	MF
R019	27/07/2023	MF
R020	27/07/2023	MF
R021	27/07/2023	MF
R022	27/07/2023	MF
R023	27/07/2023	JCL
R024	27/07/2023	JCL
R025	08/12/2023	MF
R026	15/12/2023	ML
R027	18/12/2023	MF
R028	19/12/2023	MF

GROSS SITE AREA (red) Line taken 4m from back of footpath (9m from estate road)		
Plot	Gross Site Area hectares	Gross Site Area acres
Unit 1	10.57	26.12
Unit 2	9.76	24.11
Unit 3a	8.03	19.84
Unit 3b	5.89	14.56
Unit 4	20.41	50.43
Unit 5	5.90	14.60
Unit 6	13.83	34.19
Unit 7	21.30	52.60
<b>Total</b>	<b>95.69</b>	<b>236.45</b>



Northampton Gateway  
M1 J15, Northampton  
Illustrative Masterplan

Status	Preliminary
Drawn by	PL
Checked by	RM
Date	Aug 2020
Document Number	NGW-PHP-00-00-DR-A-4054-001-P27
Scale	1:2500

Copyright reserved. Dimensions to be checked on site. Discrepancies to be reported before proceeding.

## Appendix 4 – Draft DCO Amendment Order

**2025 No. 000**

**INFRASTRUCTURE PLANNING**

**The Northampton Gateway Rail Freight Interchange  
(Amendment No.2) Order 2025**

*Made* - - - - - \*\*\*

*Coming into force* - - - - - \*\*\*

An application has been submitted under paragraph 2 of Schedule 6 to the Planning Act 2008(a) to the Secretary of State in accordance with the Infrastructure Planning (Changes to, and Revocation of, Development Consent Orders) Regulations 2011(b) for a non-material change to the Northampton Gateway Rail Freight Interchange Order 2019(c).

The Secretary of State, having considered the responses to the publicity and consultation carried out in accordance with regulations 6 and 7 of the Infrastructure Planning (Changes to, and Revocation of, Development Consent Orders) Regulations 2011, has decided to make this Order amending the Northampton Gateway Rail Freight Interchange Order 2019 (as amended by the Northampton Gateway Rail Freight Interchange (Correction) Order 2020 and the Northampton Gateway Rail Freight Interchange (Amendment) Order 2023).

The Secretary of State, in exercise of the powers conferred by paragraph 2 of Schedule 6 to the Planning Act 2008, makes the following Order—

**Citation and commencement**

1. This Order may be cited as the Northampton Gateway Rail Freight Interchange (Amendment No.2) Order 2025 and shall come into force on [DATE] 2025.

**Amendment of The Northampton Gateway Rail Freight Interchange Order 2019**

2. The Northampton Gateway Rail Freight Interchange Order 2019 (as amended by the Northampton Gateway Rail Freight Interchange (Correction) Order 2020 and the Northampton Gateway Rail Freight Interchange (Amendment) Order 2023) is amended by this Order as follows—

- (1) in article 2(1), for the definition of “highway works” substitute—  
““highway works” means the works comprised in Work Nos. 7, 7A, 8, 9, 11, 12, 13, 14, 15, 16 and 17;”
- (2) In Schedule 1 (Authorised Development) Part 1 (NSIP: The construction of a Rail Freight Interchange), in the appropriate numerical place, insert—

---

(a) 2008 c. 29.  
(b) S.I. 2011/2055.  
(c) S.I. 2019/1358 as corrected by S.I. 2020/1670 and as amended by S.I. 2023/418.

**“Works No. 7A**

Within the area of land described on the works plans as Works No. 2A—

(1) Works to the A508 roundabout that forms the access to the main site (constructed as Works No. 7) the general arrangement of which is shown on the highway plans (Document 2.4V) including—

- (a) works to signalise the A508 southbound entry-arm to the roundabout;
- (b) relocation of controlled pedestrian crossing; and
- (c) relocation of the maintenance hardstanding within the central island of the roundabout.”

(3) In Schedule 2 (requirements) Part 1 (requirements)—

- (a) in the table referred to in requirement 6, in the appropriate numerical place, insert—

<i>(1) Works as described in Schedule 1</i>	<i>(2) Description</i>	<i>(3) Stage of Development</i>	<i>(4) Relevant Body</i>
Works No. 7A(1)	Signalising of A508 southbound approach	To be completed prior to the first occupation of more than 623,000 square metres of warehousing floorspace (including 155,000 square metres of mezzanine floorspace) to be occupied.	Local highway authority

- (b) in requirement 25(1) add “save for Works No. 7A” after “None of the authorised development”;
- (c) in requirement 26(1) add “save for Works No. 7A” after “Prior to the use of any part of the completed authorised development”; and
- (d) in requirement 28(1) add “save for Works No. 7A” after “Prior to the commencement of the construction of any part of the authorised development”.

(4) In Schedule 13 (Protective Provisions) Part 3 (For the protection of the Local Highway Authority), paragraph 2(2), for the definition of “county highway works”, substitute—

““county highway works” means those parts of the authorised development to be carried out in the areas identified as Works Nos. 7, 7A, 9, 12, 13, 14, 15, 16 and 17 on the works plans, the general arrangement of which is shown on the highway plans, and any ancillary works;”

(5) In Schedule 16 (certification of plans and documents), in relation to the entry in the table for “the highway plans”—

- (a) for the Key Plan (Document number 2.4), replace the plan number in column 3 with NGW-BWB-HGN-XX-DR-C-100-P7; and
- (b) in the appropriate numerical place, insert General Arrangement Sheet 7; Document number 2.4V; plan number NGW-BWB-HGN-07-DR-C-147-P2.

(6) In Schedule 16 (certification of plans and documents), in relation to the entry in the table for “the parameters plan” (Document number 2.10), replace the plan number in column 3 with 4054-R007-S4.

(7) In Schedule 16 (certification of plans and documents), in relation to the entry in the table for “the works plans”—

- (a) for the Key Plan (Document 2.2), replace the plan number in column 3 with NGW-BWB-LSI-XX-DR-C-00160-P16; and

(b) in the appropriate numerical place, insert Sheet 8; Document 2.2H; plan number NGW-BWB-LSI-07-DR-C-00168-P4.

Signed by the authority of the Secretary of State for Transport

	<i>Name</i>
Address	Head of the Transport and Works Act Order Unit
Date	Department for Transport

**EXPLANATORY NOTE**

*(This note is not part of the Order)*

This Order amends The Northampton Gateway Rail Freight Interchange Order 2019 (as amended by the Northampton Gateway Rail Freight Interchange (Correction) Order 2020 and the Northampton Gateway Rail Freight Interchange (Amendment) Order 2023), a development consent order under the Planning Act 2008.

This Order follows an application under paragraph 2 of Schedule 6 to the Planning Act 2008 for a non-material change to allow for an increase in the amount of mezzanine floor space to be provided as part of the authorised development (with the increase being 1.2 million sqft (111,480 sqm)) and the carrying out of certain highway improvement works in respect of the southbound approach to the site access roundabout on the A508.

**Appendix 5 – Proposed revised Parameters Plan (Doc 2.10 Ref. 4054-R007 – Rev S4)**

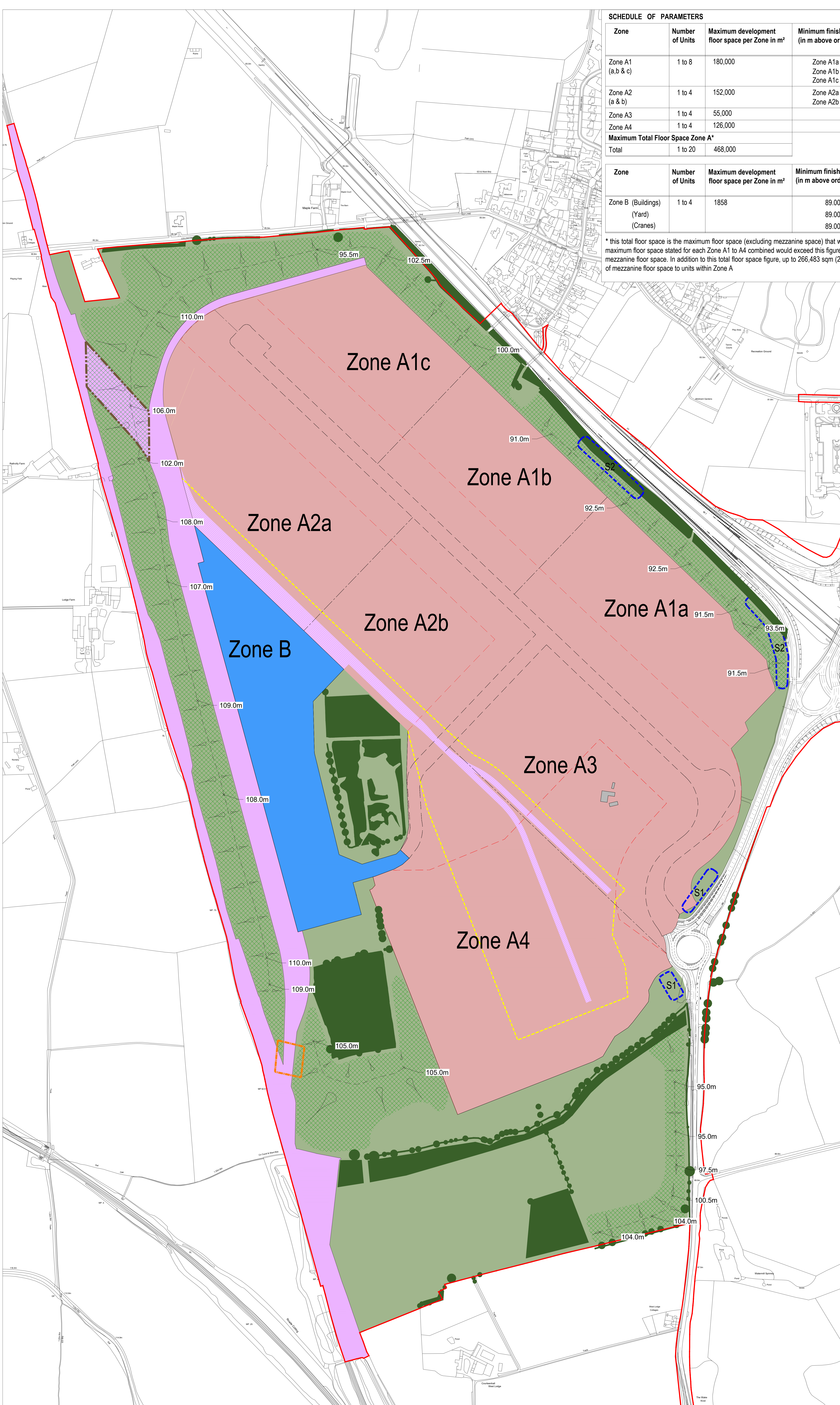

SCHEDULE OF PARAMETERS				
Zone	Number of Units	Maximum development floor space per Zone in m <sup>2</sup>	Minimum finished floor level (in m above ordnance datum)	Maximum building height measured to roof ridge / highest point (in metres above ordnance datum)
Zone A1 (a, b & c)	1 to 8	180,000	Zone A1a 81.50 Zone A1b 83.50 Zone A1c 84.00	104.00 104.00 104.00
Zone A2 (a & b)	1 to 4	152,000	Zone A2a 90.00 Zone A2b 89.50	109.50 109.50
Zone A3	1 to 4	55,000	89.00	109.50
Zone A4	1 to 4	126,000	88.50	109.00
<b>Maximum Total Floor Space Zone A*</b>				
Total	1 to 20	468,000		

Zone	Number of Units	Maximum development floor space per Zone in m <sup>2</sup>	Minimum finished ground level (in m above ordnance datum)	Maximum height measured to roof ridge / highest point (in metres above ordnance datum)
Zone B (Buildings)	1 to 4	1858	89.00	Buildings 103.00
(Yard)			89.00	Yard 105.00
(Cranes)			89.00	Gantry Cranes 110.50

\* this total floor space is the maximum floor space (excluding mezzanine space) that will be developed across Zone A notwithstanding that the maximum floor space stated for each Zone A1 to A4 combined would exceed this figure i.e. it is the overall floor space cap for Zone A excluding mezzanine floor space. In addition to this total floor space figure, up to 266,483 sqm (2,868,399 sqft) of floor space can be provided in the form of mezzanine floor space to units within Zone A

- LEGEND**
- Open Land / Landscaping including landscape screen bunding, attenuation ponds & retained agricultural land
  - Existing woodland to be retained
  - Estate roads
  - Limits of deviation to Estate roads
  - Rail corridor including new rail line and landscaping
  - Rail corridor within development zones
  - Limits of deviation to rail corridor within development zones
  - Zone A development area
  - Zone boundaries within development area
  - Zone B rail freight interchange
  - Order Limits
  - S1 = Sign Board max size (including supporting frame) 7.5m High x 18.3m Wide x 1.3m Deep
  - S2 = Totem Sign max size (including supporting frame) 15.5m High x 4.0m Wide x 4.0m Deep
  - Farm buildings to be demolished
  - Areas within which strategic screen bunding is to be provided
  - Fixed spot heights in metres above ordnance datum, identified along the ridgeline of each length of strategic screen bund
  - 107.0m
  - 109.0m
  - Between any two consecutive spot heights marked on the ridge, the height of the bund, at its ridge, will be no lower than the lower of the two spot heights and no higher than the higher of the two spot heights
  - 108.0m
  - Corridor for rail tunnel through strategic screen bunding
  - Corridor for pedestrian footbridge over new rail line

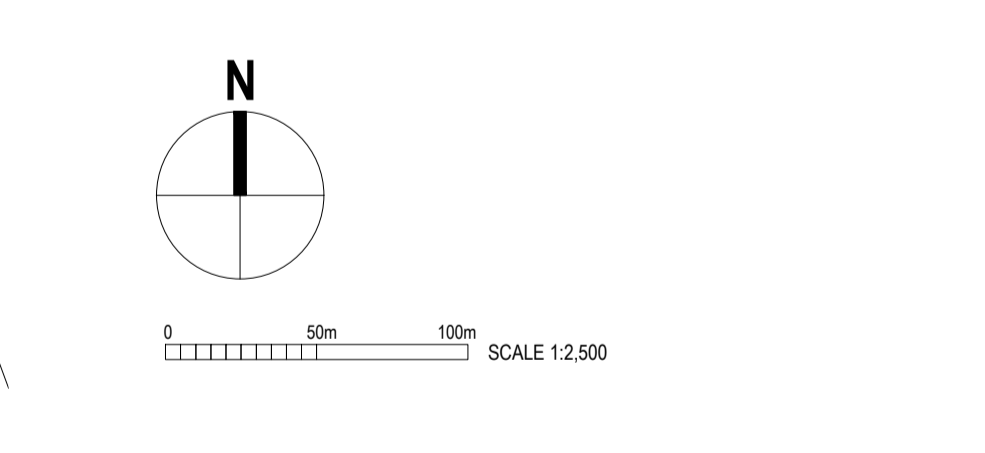

Rev	Date	Details of issue / revision	Drawn	Rev
S2	11.02.2019	Rail tunnel corridor re-aligned, top of bund spot heights		2.10
S3	18.03.2020	Mezzanine floor area figure amended		2.10
S4	09.04.2020	Roundoff logs removed		2.10

**ISSUES & REVISIONS**

**SEGRO**

**NORTHAMPTON GATEWAY**  
STRATEGIC RAIL FREIGHT INTERCHANGE

**THE NORTHAMPTON GATEWAY RAIL FREIGHT INTERCHANGE ORDER 201X**

Drawing Title:  
**PARAMETERS PLAN**

Scale	1:2,500	Drawn	RM
Size	A0	Reviewed	SH
Regulation	Document		
<b>Reg 5(2)(o)</b>	<b>2.10</b>		

Drawing Status:  
**SUBMISSION**

Drawing No.	4054 - R007	Revision	S4
-------------	-------------	----------	----

**Appendix 6 – Transport Technical Note (by ADC Infrastructure)**



# **SUMMARY STATEMENT ON TRAFFIC AND TRANSPORT**

**NORTHAMPTON GATEWAY SRFI  
DCO AMENDMENT TO INCREASE MEZZANINE FLOOR SPACE**

## DOCUMENT CONTROL

project number: ADC3519			report reference: ADC3519-RP-B	
version	date	author	reviewer	comments
1	07/03/2025	Stuart Dunhill		draft issued for comment
2	28/03/2025	Stuart Dunhill	Mark Higgins	issued for submission
3	01/05/2025	Stuart Dunhill	Mark Higgins	updated and issued for submission

## CONTENTS

<b>1.0 INTRODUCTION .....</b>	<b>4</b>
<b>2.0 TRANSPORT ASSESSEMENT ADDENDUM .....</b>	<b>5</b>
<b>3.0 CONSULTATION WITH HIGHWAY AUTHORITIES .....</b>	<b>6</b>
National Highways .....	6
West Northampton Council .....	6

## APPENDICES

Appendix 1	Transport Assessment Addendum
Appendix 2	Supporting letter
Appendix 3	National Highways correspondence

## 1.0 INTRODUCTION

- 1.1 SEGRO Plc (the Applicant) have commissioned ADC Infrastructure Ltd to provide transport advice with regards to an application to amend the Development Consent Order (DCO) for their Northampton Gateway Strategic Rail Freight Interchange (SRFI) development.
- 1.2 The amendment to the DCO is required in response to changes in market demand, as occupiers now require much greater volumes of mezzanine floor space than was previously the case. SEGRO are therefore seeking to amend the maximum amount of mezzanine floor space that is permitted under the DCO. This will safeguard the future build out of the SRFI site by ensuring that it can provide an appropriate mix of floor space and hence remain attractive to occupiers, whilst also maximising the floor space available in proximity to the rail terminal.
- 1.3 SEGRO are seeking to increase the amount of site wide mezzanine floor space that can be constructed at Northampton Gateway SRFI by 1.2 million sqft (111,480 sqm).
- 1.4 This summary statement, brings together the assessment work undertaken to consider the likely transport impacts of the proposed amendment to the DCO, including a summary of the position agreed with National Highways and the ongoing dialogue with West Northamptonshire Council (WNC). It concludes that the proposed amendment will have no severe traffic impacts, and no additional significant environmental effects as compared to the scheme as consented.

## 2.0 TRANSPORT ASSESSEMENT ADDENDUM

2.1 A Transport Assessment (TA) Addendum (**Appendix 1**) has been prepared to assess the transport impact of the proposed amendment to increase the mezzanine floor space allowance at Northampton Gateway SRFI.

2.2 The key findings of the TA Addendum are:

- As part of the DCO for Northampton Gateway, a comprehensive package of highway mitigation measures is approved and consented. The highway improvement measures include a major upgrade to M1 Junction 15 and the A45, improvements to M1 Junction 15A, a bypass for the village of Roade, the implementation of environmental weight restrictions, improvements along the A508 as part of the A508 route upgrade, and financial contributions towards improvements to the A45 Queen Eleanor Interchange, and junctions along the A5076, and a Knock Lane and Blisworth Road maintenance and minor works fund.
- The construction of the offsite highway works commenced in 2021, and all the highway improvements are now complete and open to traffic.
- Walking and cycling strategies were developed in agreement with the highway authorities as part of the DCO. These are in the process of being put in place both within the development and off-site on the highway network, to provide enhanced connectivity from the SRFI site for pedestrians and cyclists to Collingtree, Northampton, and Roade.
- The internal and external footway/cycleway network provides significantly improved connections to the residential areas within the walking and cycling catchments and therefore, there are direct and safe walking and cycling routes to and from the SRFI.
- As part of the DCO, a public transport strategy was developed which includes the introduction of a new bus service specifically serving the SRFI site, as well as building on the existing local bus network and providing additional bus stops on the A508 to the north and south of the A508/site access roundabout.
- The proposal to increase the mezzanine floor space allowance at the SRFI site could increase the off-site vehicle trips by 105 two-way trips in the morning peak hour and 128 two-way vehicle trips in the evening peak hour. The assessment of the traffic impact has not considered the beneficial effect of the Travel Plan in reducing vehicle trips and therefore represents a robust position.
- The additional mezzanine floor space could generate up to 11 additional public transport trips, and five additional walking and cycling trips during a peak hour period.

2.3 The TA Addendum assessed the impact of the additional trips on the transport infrastructure. It concluded, subject to a minor improvement scheme at the SRFI site access roundabout on the A508, that the transport impacts arising from the increased mezzanine floor space would continue to be mitigated by the infrastructure improvements consented and delivered as part of the DCO, with residual impacts reduced to acceptable levels.

2.4 Accordingly, the proposed amendment will have no severe traffic impacts, and no additional significant environmental effects as compared to the scheme as consented.

### 3.0 CONSULTATION WITH HIGHWAY AUTHORITIES

- 3.1 The TA Addendum report was submitted on 19 September 2024 to National Highways, who are responsible for the Strategic Road Network, and WNC who are the local highway authority.
- 3.2 As part of their review process, National Highways requested additional information. This was provided via a letter submission to National Highways dated 29 November 2024 (**Appendix 2**).

#### National Highways

- 3.3 Following their review of the TA Addendum and the additional information, National Highways confirmed in their email dated 15 January 2025 (**Appendix 3**) that they have no objection to the proposed amendment to the DCO to increase the mezzanine floor space at Northampton Gateway SRFI.

#### West Northampton Council

- 3.4 Confirmation of the National Highways position, along with the additional information submitted to National Highways, was also submitted to WNC on 28 January 2025.
- 3.5 WNC provided a response on 11 April 2025. However, the response received considered only the original information submitted during September 2024 but did not consider the more recent submission to them made during January 2025 and the agreement reached with National Highways. The Applicant therefore met with WNC on 1 May 2025 to discuss the proposed DCO amendment and have agreed to submit additional information to allow WNC to confirm agreement to the findings of the TA Addendum. Given the length of time (7 months) taken for WNC to respond, the Applicant does not wish to delay submission of the DCO amendment application any further. Therefore, the dialogue with WNC will continue and an update will be provided in due course.

## APPENDIX 1

# TRANSPORT ASSESSMENT ADDENDUM



# **TRANSPORT ASSESSMENT ADDENDUM**

**NORTHAMPTON GATEWAY SRFI  
DCO AMENDMENT TO INCREASE MEZZANINE FLOOR SPACE**

## DOCUMENT CONTROL

project number: ADC3519			report reference: ADC3519-RP-A	
version	date	author(s)	reviewer	comments
1	22/05/2024	Stuart Dunhill and Mark Higgins	Mark Higgins	internal draft
2	23/05/2024	Stuart Dunhill and Mark Higgins	Mark Higgins	issued to client

## CONTENTS

<b>1.0</b>	<b>INTRODUCTION .....</b>	<b>4</b>
<b>2.0</b>	<b>CONSENTED DEVELOPMENT AND INFRASTRUCTURE .....</b>	<b>5</b>
	Site location.....	5
	Highway network .....	5
	Highway mitigation .....	6
	Walking and cycling infrastructure improvements.....	7
	Public Transport Strategy .....	11
	Summary .....	13
<b>3.0</b>	<b>TRIP GENERATION.....</b>	<b>15</b>
	Development Proposals.....	15
	Assessment of mezzanine floor space .....	15
	Vehicle trip generation .....	15
	Person trip generation .....	16
<b>4.0</b>	<b>TRIP DISTRIBUTION AND ASSIGNMENT .....</b>	<b>18</b>
	Vehicle trip distribution .....	18
	Vehicle trip assignment.....	18
<b>5.0</b>	<b>ASSESSMENT OF IMPACTS.....</b>	<b>19</b>
	Introduction.....	19
	Assessment flows .....	19
	A508 site access roundabout .....	19
	M1 Junction 15 .....	21
	Impact of additional person trips .....	22
<b>6.0</b>	<b>SUMMARY AND CONCLUSIONS .....</b>	<b>23</b>

## DIAGRAMS

Diagram 1	Trip distribution – AM peak hour
Diagram 2	Trip distribution – PM peak hour
Diagram 3	Additional mezzanine floor space development traffic – AM peak hour
Diagram 4	Additional mezzanine floor space development traffic – PM peak hour
Diagram 5	2031 background traffic flows with SRFI in place – AM peak hour
Diagram 6	2031 background traffic flows with SRFI in place – PM peak hour
Diagram 7	2031 total traffic flow – AM peak hour
Diagram 8	2031 total traffic flow – PM peak hour

## APPENDICES

Appendix A	DCO Parameters Plan
Appendix B	A508/site access LinSig assessment results
Appendix C	M1 Junction 15 LinSig assessment results

## 1.0 INTRODUCTION

- 1.1 SEGRO Plc have commissioned ADC Infrastructure Ltd to prepare a Transport Assessment (TA) Addendum to support an application to amend the Development Consent Order (DCO) for their Northampton Gateway Strategic Rail Freight Interchange (SRFI) development.
- 1.2 The amendment is required in response to changes in market demand, as occupiers now require much greater volumes of mezzanine floor space than was previously the case. SEGRO are therefore seeking to amend the maximum amount of mezzanine floor space that is permitted under the DCO. This will safeguard the future build out of the SRFI site by ensuring that it can provide an appropriate mix of floor space and hence remain attractive to occupiers.
- 1.3 In addition, West Northamptonshire Council are preparing their New Local Plan, which will guide development in the period up to 2041. Their Regulation 18 consultation draft document identifies a short fall of strategic warehousing space within West Northamptonshire during the plan period (this shortfall is notwithstanding the permitted development at the SRFI).
- 1.4 To meet this shortfall, draft Policy N8 identifies a single site for B8 warehousing located opposite Northampton Gateway SRFI. In identifying the most appropriate location for such development, paragraph 5.7.6 of the Regulation 18 consultation draft document notes the opportunity to provide a “...facility in close proximity to the motorway and adjacent to the rail freight terminal which is currently being constructed”. Paragraph 5.7.7 notes that “...connection to a strategic railfreight interchange will allow the industry to perform and progress in a sustainable manner.”
- 1.5 The location of the draft B8 allocation, adjacent to Northampton Gateway SRFI, demonstrates the importance of the SRFI site. This reinforces that opportunities to realise the development potential at the SRFI site should be maximised.
- 1.6 SEGRO are seeking to increase the amount of mezzanine floor space that can be delivered at Northampton Gateway SRFI by 1.2 million sqft (111,480 sqm).
- 1.7 This TA Addendum report has therefore been prepared to assess the implications of increasing the maximum mezzanine floor space permitted at Northampton Gateway SRFI by this amount. The DCO was supported by the approved TA<sup>1</sup>. This TA Addendum therefore revisits the approved TA work. It is structured as follows:
  - Section 2 provides a summary of development and highway infrastructure improvements consented under the Northampton Gateway SRFI DCO.
  - Section 3 considers the trip generation associated with the increased mezzanine floor space (based on the assumptions in the approved TA).
  - Section 4 assigns the additional development traffic to the highway network using the distributions from the approved TA.
  - Section 5 examines the impact of the additional development trips on the transport network.
- 1.8 Subject to an improvement scheme at the SRFI site access roundabout on the A508, Section 6 concludes that the transport impacts arising of the increased mezzanine floor space would continue to be mitigated by the consented highway infrastructure, and that the residual impacts are reduced to acceptable levels. Accordingly, there should be no objection to the proposed DCO amendment.

---

<sup>1</sup> Northampton Gateway Strategic Rail Freight Interchange Transport Assessment, report reference ADC1475 TA ver 4, ADC Infrastructure, 8 May 2018. ([planninginspectorate.gov.uk](http://planninginspectorate.gov.uk))

## 2.0 CONSENTED DEVELOPMENT AND INFRASTRUCTURE

- 2.1 The DCO for Northampton Gateway SRFI was granted in October 2019. It consents for the following development at the Northampton Gateway SRFI site:
- an intermodal freight terminal including container and HGV parking, rail sidings to serve individual warehouses, and the provision of an aggregates facility as part of the intermodal freight terminal, with the capability to also provide a rapid rail freight facility;
  - up to 468,0000 sqm of warehousing and ancillary buildings, with additional floorspace provided in the form of mezzanines;
  - a secure, dedicated, HGV parking area of approximately 120 spaces including driver welfare facilities to meet the needs of HGVs visiting the site or intermodal terminal;
  - new road infrastructure and works to the existing road network, including the provision of a new access and associated works to the A508, a new bypass to the village of Roade, improvements to Junction 15 and to J15A of the M1 motorway, the A45, and other highway improvements at junctions on the local highway network and related traffic management measures;
  - strategic landscaping and tree planting, including diverted public rights of way;
  - earthworks and demolition of existing structures on the SRFI site.
- 2.2 The maximum mezzanine floor space permitted under the DCO is given on the DCO Parameters Plan (**Appendix A**). This permits up to 155,000 sqm of mezzanine floor space across the site.

### Site location

- 2.3 The Northampton Gateway SRFI site is located within the administrative area of West Northamptonshire Council. It is located to the west of M1 Junction 15, approximately 6km from Northampton Town Centre. A general site location plan is shown at **Figure 1**. It is bounded to the northeast by the M1 motorway, to the southeast by the A508, to the north by Collingtree Road, and by the Northampton Loop line of the West Coast Main Line (WCML) railway to the west.
- 2.4 West Northamptonshire Council is the local highway authority (formally Northamptonshire County Council), and National Highways has responsibility for the Strategic Road Network (SRN), which near the site comprises the M1 motorway, M1 Junctions 15 and 15A, the A45, and the A43.

### Highway network

- 2.5 The highway network adjacent to the site is shown in **Figure 1**, which is described in detail in the approved TA for the DCO.
- 2.6 The Northampton Gateway SRFI site access is located on the A508. The A508 runs from its junction with the M1 and the A45 (M1 Junction 15) in the north, to the A5 at the A5/ A508/ A422/ Towcester Road roundabout in Old Stratford to the south.
- 2.7 The M1 motorway is a strategic route for local, regional, and international traffic and plays an important role as a direct motorway between the north and south and a major route connecting some of the largest conurbations in the UK. The A45 provides a route around the eastern edge of Northampton and connects with the A14 to the north.
- 2.8 Hence in terms of the SRN, the Northampton Gateway SRFI site provides excellent connection opportunities with the rest of the UK, via the M1, A45, A14 and A43.



Figure 1: general site location

### Highway mitigation

2.9 As part of the DCO for the Northampton Gateway SRFI, a comprehensive package of highway mitigation measures was approved and consented. The full package of works comprises the following:

- A new roundabout on the A508 Northampton Road to serve as the access to the development, configured to require all departing HGVs to travel north to M1 Junction 15;
- Dualling of the A508 between the new site access roundabout and M1 Junction 15;
- Significant enlargement and reconfiguration of M1 Junction 15;
- Widening of the A45 to the north of M1 Junction 15 and the signalisation of the Watering Lane junction;
- Alteration of M1 Junction 15A to provide an additional lane and signalisation on the A43 northbound approach, signal control and additional flared lane on the A43 eastbound approach, an additional lane on the A5123 southbound approach and circulatory carriageway widening;
- Construction of a new bypass west of Roade between the A508 Northampton Road to the north of Roade and the A508 Stratford Road to the south of Roade, including a four-arm roundabout connecting the Bypass to Blisworth Road;
- 7.5T environmental weight restrictions (with access permitted for loading):
  - throughout Roade;
  - along Knock Lane/Blisworth Road between Roade Bypass and Stoke Road;

- along Blisworth Road (Courteenhall Road) between the A508 and High Street, including parts of Blisworth;
- along the unnamed road between the A508 and Quinton;
- throughout Stoke Bruerne and Shutlanger; and
- Wootton & East Hunsbury, to the west of the A45, east of Towcester Road and south of the A5076.
- Improvements at key locations along the A508 as part of an ‘A508 route upgrade’; comprising:
  - Blisworth Road (Courteenhall) junction improvement;
  - C26 Rookery Lane/Ashton Road junction improvement;
  - C85 Pury Road junction improvement;
  - C27 Stoke Road/Knock Lane junction improvement and additional widening to Knock Lane/Blisworth Road (although not on the A508, this is required because of changing traffic volumes on the A508); and
  - Provision of a pedestrian crossing at a bus stop and ghost island in Grafton Regis.
- A financial contribution provided for:
  - improvement schemes at the A45 Queen Eleanor Interchange and at junctions along the A5076, extending between the A45 and A5123; and
  - a Knock Lane and Blisworth Road maintenance and minor works fund, to be used in the event that the increased use of the roads should advance the need for maintenance or other remedial works.

2.10 The approved highway mitigation measures are necessary to provide satisfactory access to the Northampton Gateway SRFI as a whole and to mitigate the traffic impacts of the development. It was demonstrated via the DCO that the highway mitigation works also release existing constraints on the A508, M1 and A45 corridors, allowing the highway network to function in a safer and more efficient manner, and allowing the benefits of the proximity of the SRFI site to M1 Junction 15 to be fully realised.

2.11 The phased construction of the offsite highway works described above also commenced in 2021 and are now largely complete. The new site access roundabout on the A508 Northampton Road, dualling of the A508 between the new site access roundabout and M1 Junction 15, the significant enlargement and reconfiguration of M1 Junction 15, the Roade Bypass, and the upgrade of M1 Junction 15A are all open to traffic. Except for works on the A508 associated with the access to the Courteenhall Estate, all the A508 route upgrade highway works are also complete and open to traffic.

### **Walking and cycling infrastructure improvements**

2.12 The conditions for pedestrians and cyclists prior to the development of the SRFI are described in detail in the Walking, Cycling & Horse-Riding Assessment review (WCHAR) Report that is part of the Transport Assessment for the Northampton Gateway SRFI development.

2.13 It was concluded that there are good opportunities for pedestrian and cycle travel associated with the SRFI. However, the WCHAR found that the M1 could provide a barrier to pedestrian and cycle travel to/from the northeast of the site, where the residential areas within walking distance are located.

2.14 Therefore, as part of the DCO for the wider site, walking and cycling strategies were developed in agreement with the highway authorities, both within the development and off-site on the local highway network, to provide further connectivity from the SRFI site to Collingtree, Northampton, and Roade. These improvements have now been implemented or are under construction.

- 2.15 The SRFI access roundabout is now constructed and provides a puffin crossing on the A508 northern arm of the roundabout to facilitate access to the new southbound bus stop. A Toucan crossing is provided on the segregated left-turn exit lane of the SRFI site access arm, with uncontrolled crossings provided on the right turn exit and entry arm to the SRFI site. A shared footway/cycleway runs around the roundabout and connects into the site access. The footway/cycleway provides a connection to the new northbound bus stop that has been provided to the south of the site access roundabout on the A508.
- 2.16 This new footway/cycleway extends alongside the west side of the A508, linking the site access roundabout with M1 Junction 15 to the north. The footway/cycleway also extends south, providing a connection to the footway/cycleway facility that is provided alongside the western side of the A508 Road Bypass. When taken together, the new facilities provide a shared use footway/cycleway connecting Road with the site and the existing Northampton footway/cycleway network to the north.
- 2.17 At the southwest corner of M1 Junction 15, a direct pedestrian and cycle connection to Northampton Gateway SRFI is provided. This pedestrian and cycle access links to the internal off-street footway/cycleway network and connects to the estate road at the first internal roundabout. A further pedestrian and cycle access (and emergency access) to the SRFI is provided approximately halfway between the site access roundabout and M1 Junction 15, providing further direct access.
- 2.18 Within the Northampton Gateway SRFI site, a shared footway/cycleway is provided between the A508/site access roundabout and the first internal roundabout, with shared footway/cycleway facilities provided on both sides of the main estate road. In due course, pending the development of Zones A1b/c of the SRFI site, a further shared footway/cycleway will be provided linking directly from the estate road to the Collingtree bridge over the M1.
- 2.19 Guidelines for Providing Journeys on Foot<sup>2</sup> describes acceptable walking distances for pedestrians without mobility impairment. They suggest that for commuters up to 500m is the desirable walking distance, up to 1km is an acceptable walking distance, and up to 2km is the preferred maximum walking distance. As shown in **Figure 2**, a 2km catchment from the site includes Collingtree, Milton Malsor, and Grange Park.
- 2.20 The South Northampton Sustainable Urban Extension (SUE), which is a committed development of some 1,000 dwellings, is located just outside the preferred maximum walking distance. However, with the new non-motorised strategies that the DCO consents, the SUE development will be within an acceptable walking distance.

---

<sup>2</sup> Guidelines for Providing for Journeys on Foot, Institution of Highways and Transportation, 2000

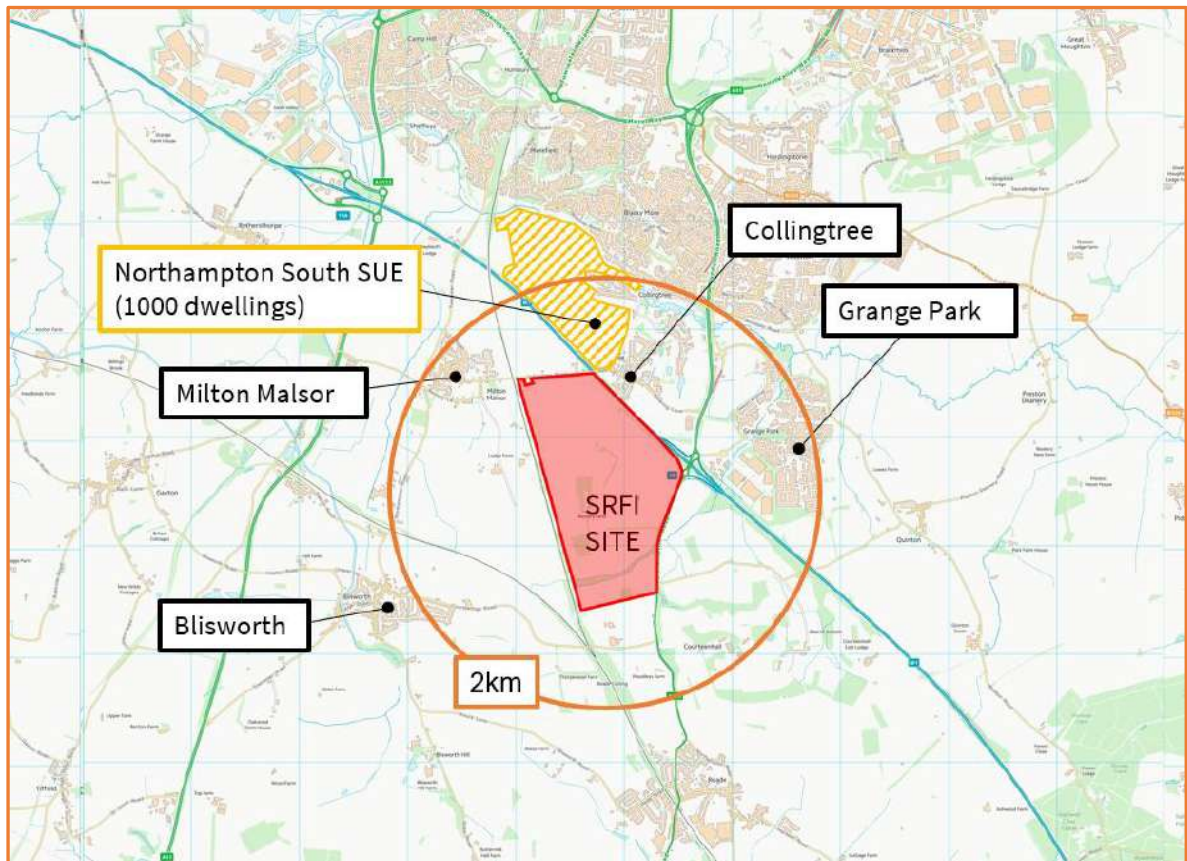

Figure 2: pedestrian catchment area

- 2.21 Two public footpaths previously ran through the wider Northampton Gateway SRFI development site (KX13 and KX17). These public rights of way have been diverted in accordance with the DCO consent, providing new routes around the SRFI site.
- 2.22 Cyclists are typically prepared to cycle up to 5km for non-leisure journeys, such as those to work. However, statistics published in the National Travel Survey showed that commuting cyclists typically cycled 23 minutes from their home to their place of work. Typical guidance also suggests an average cycle speed of 12mph. Combining these two factors, a cyclist travelling at 12mph for 23 minutes will cover a distance of 7.4km. **Figure 3** therefore shows a 5km and 7.4km cycle catchment from the centre of the site.
- 2.23 A 5km cycle catchment includes a large portion of southern Northampton and the surrounding villages, including Road to the south. Northampton Railway Station falls just outside the 5km catchment but would still be within an acceptable cycle distance for regular commuters. A 7.4km cycle catchment also includes Northampton Town Centre.

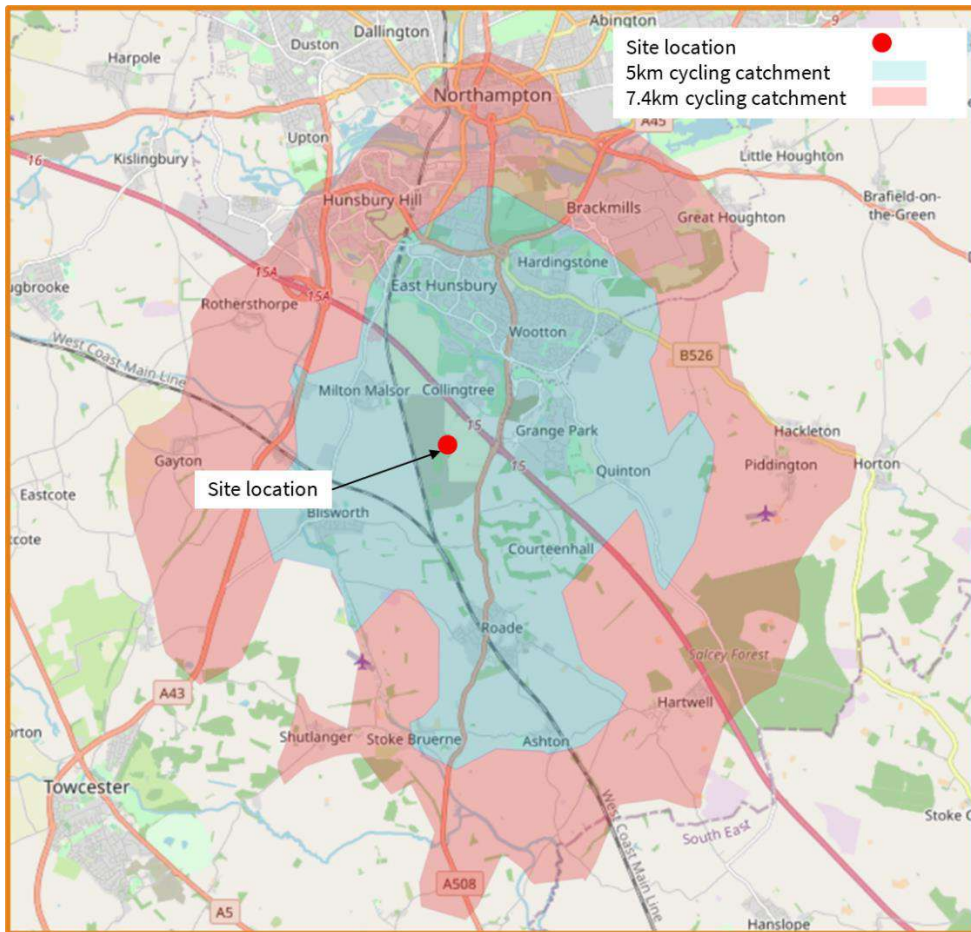

Figure 3: cycle catchment area

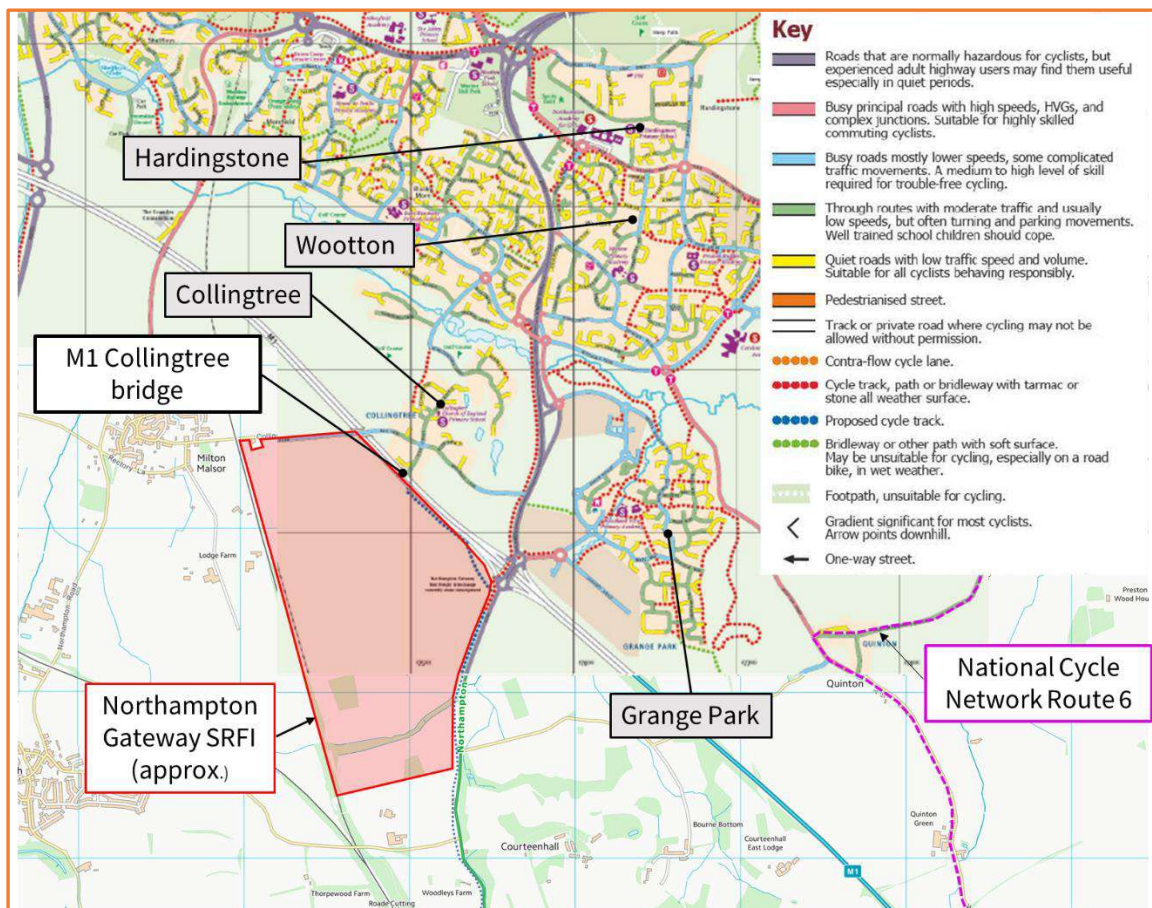

Figure 4: cycle routes (composite based on extract of Northampton cycle map)

- 2.24 As shown in **Figure 4**, there are a network of cycle facilities and Advisory Routes within East Hunsbury that provide onwards connection to Northampton and are accessible via Collingtree. There is also a network of cycle facilities within Grange Park, providing onwards links to the Wootton and Hardingstone residential area. **Figure 4** also shows some of the cycle improvements consented as part of the DCO (proposed cycle track on the NCC map).
- 2.25 National Cycle Network Route 6 is located to the east of the site as shown on **Figures 4 and 5**. The route encompasses Quinton, Hardingstone (including the Hardingstone SUE), and Brackmills Industrial Estate, en-route to Northampton Town Centre.

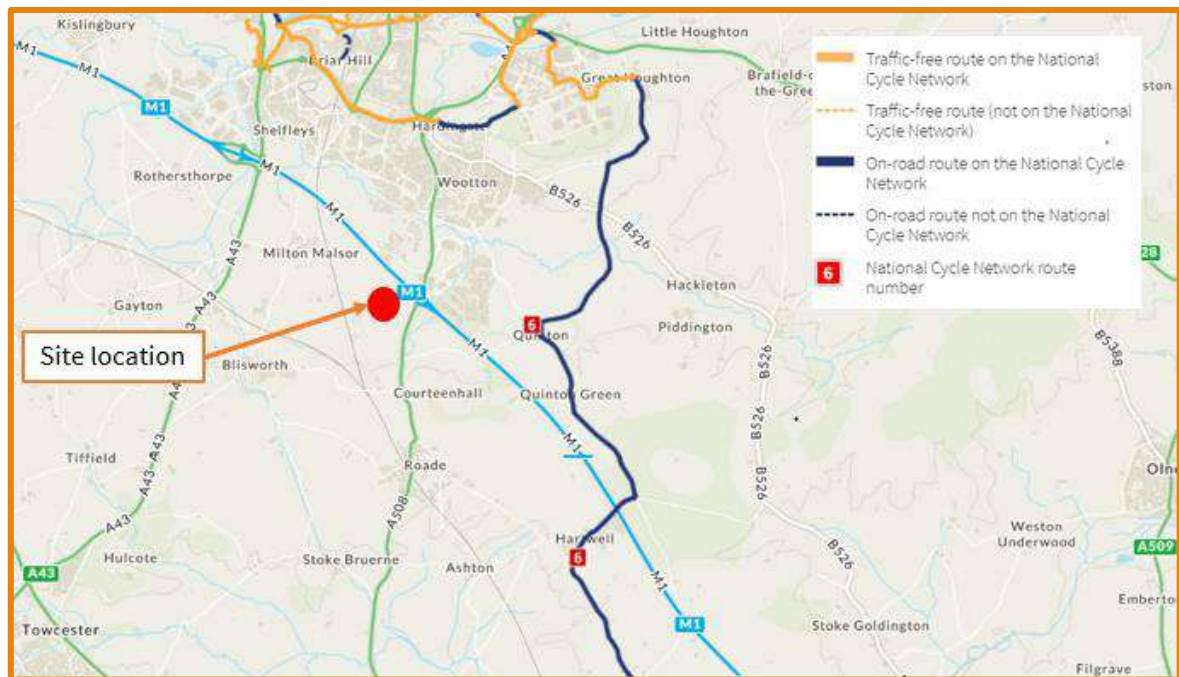

Figure 5: extract of national cycle map

- 2.26 The improvement works at M1 Junction 15 provide traffic signal-controlled facilities at each crossing location. A new shared use pedestrian and cycle link has been provided from M1 Junction 15 along the A45, linking with the Watering Lane to the north.
- 2.27 The consented improvements at the Watering Lane junction with the A45 have been completed, with Toucan crossings provided on the Watering Lane arm to assist pedestrians and cyclists accessing the shared footway/cycleway facility on the northern side of Watering Lane. In addition, an uncontrolled crossing is provided between the hotel and the footway on the northern side of Watering Lane, west of the A45 junction.
- 2.28 The internal and external footway/cycleway network therefore provides significantly improved connections to the residential areas within the walking and cycling catchments with appropriate crossing facilities provided. Therefore, there are direct and safe walking and cycling routes to and from the SRFI.

### Public Transport Strategy

- 2.29 The existing bus services near to the site are shown in **Figure 6**, with the 33, the 33A and the X6 currently passing immediately in front of the site on the A508. All services provide a route from Northampton to Milton Keynes.



Figure 6: bus routes

- 2.30 The number 33 bus provides two services in the morning and two in the evening. The X6 runs from 06:31 (at the bus stop in Road) with seven services between 06:31 to 10:24 and then roughly every half an hour until 20:12. All services provide a connection to Northampton bus interchange.
- 2.31 As part of the DCO for the Northampton Gateway SRFI development, a public transport strategy was developed which includes the introduction of a new bus service specifically serving the SRFI site, as well as building on the existing local bus network and providing additional bus stops on the A508 to the north and south of the A508/SRFI site access roundabout, giving access to the 33/33A and the X6 services. The strategy is explained in detail in the TA that accompanied the DCO and is summarised below.
- 2.32 The new bus service to/from Northampton Gateway SRFI will be introduced in four phases. The initial phase will involve the introduction of the service at key shift times, most likely around 0600-1400-2200 hours, but will be flexible to end users' requirements. A requirement of the DCO is that prior to commencement of the construction of any warehousing, the Sustainable Transport Working Group will be established, who will have oversight of the Framework Travel Plan and Public Transport Strategy.
- 2.33 Once the first phase of the bus service has been established, the Sustainable Transport Working Group will monitor the opportunity of continuing the bus service between peaks, to develop a

regular bus service for users throughout the day, and as demand grows, to increase the service frequency from hourly to half hourly.

- 2.34 The proposed bus service will offer direct access from the SRFI site to Northampton Town Centre. The most direct route would see the service following the A508/A45/A508 to The Drapery (or North Gate Bus Station). As well as serving the town centre, the service could also serve stops on London Road (A508). On the SRFI site, the service would use the SRFI access on the A508, enter the site, serving the bus stops on the estate road and use the turning circle (roundabout) at the westerly end of the site.
- 2.35 The nearest railway station is Northampton which is approximately 6km to the north of the proposed development and on the WCML loop from Birmingham to London. The station can be accessed via cycle or a bus to the North Gate Bus Station and the railway station is within a 10 minutes' walk of the bus station. There is a traffic free/lightly trafficked cycle route to the station. The railway station is served by a good service to and from Rugby, at least every 20 minutes at peak times, together with direct trains to London and Birmingham. The opportunity will therefore exist for staff to travel by train to Northampton and complete their journey either by cycle or via the connecting bus services.

### Summary

- 2.36 The principle that Northampton Gateway SRFI is a suitable location for B8 employment use was established as part of the DCO for the scheme. This is reinforced by West Northamptonshire Council's New Local Plan Regulation 18 document, which puts forward the land adjacent to Northampton Gateway SRFI as suitable for B8 development.
- 2.37 Northampton Gateway SRFI is located adjacent to M1 Junction 15 and hence provides excellent connection opportunities with the whole of the UK, via the M1, A45, A14, A43 and A5.
- 2.38 As part of the DCO for Northampton Gateway, a comprehensive package of highway mitigation measures is approved and consented. The highway improvement measures include a major upgrade to M1 Junction 15 and the A45, improvements to M1 Junction 15A, a bypass for the village of Roade, the implementation of environmental weight restrictions, improvements along the A508 as part of the A508 route upgrade, and financial contributions towards improvements to the A45 Queen Eleanor Interchange, and junctions along the A5076, and a Knock Lane and Blisworth Road maintenance and minor works fund.
- 2.39 The construction of the offsite highway works commenced in 2021 and are now largely complete. The new site access roundabout on the A508 Northampton Road, dualling of the A508 between the new site access roundabout and M1 Junction 15, the significant enlargement and reconfiguration of M1 Junction 15, the Roade Bypass, and the upgrade of M1 Junction 15A are all open to traffic. Except for works on the A508 associated with the access to the Courteenhall Estate, all the A508 route upgrade highway works are also complete and open to traffic.
- 2.40 Walking and cycling strategies were developed in agreement with the highway authorities as part of the DCO. These are in the process of being put in place both within the development and off-site on the highway network, to provide enhanced connectivity from the SRFI site for pedestrians and cyclists to Collingtree, Northampton, and Roade. The measures are summarised as follows:
- A comprehensive network of both on street and off-street shared footway/cycleways throughout the SRFI site with appropriate crossing points provided.

- New footway/cycleway facilities alongside the A508, linking the site access roundabout with the Roade bypass to the south and M1 Junction 15 to the north, with signal controlled crossing facilities at the site access roundabout providing access to new bus stops.
- A comprehensive upgrade of walking and cycling facilities at M1 Junction 15 including Toucan crossings at all crossing points.
- New footway/cycleway between M1 Junction 15 and the junction with Watering Lane, with Toucan crossing to connect to the existing facilities to the north.
- Public footpaths KX17 and KX13 that cross the SRFI site have been diverted and extended to form a loop within the landscape bunding.
- A cycle track (for use by pedestrians and cyclists) connecting the development to Collingtree, and the wider Northampton area, via the existing bridge over the M1.

2.41 The internal and external footway/cycleway network provides significantly improved connections to the residential areas within the walking and cycling catchments and therefore, there are direct and safe walking and cycling routes to and from the SRFI.

2.42 As part of the DCO, a public transport strategy was developed which includes the introduction of a new bus service specifically serving the SRFI site, as well as building on the existing local bus network and providing additional bus stops on the A508 to the north and south of the A508/site access roundabout.

### 3.0 TRIP GENERATION

#### Development Proposals

- 3.1 The amendment to the DCO is required in response to changes in market demand, as occupiers now require much greater volumes of mezzanine floor space than was previously the case. SEGRO are therefore seeking to amend the maximum amount of mezzanine floor space that is permitted under the DCO. This will safeguard the future build out of the SRFI site by ensuring that it can provide an appropriate mix of floor space and hence remain attractive to occupiers.
- 3.2 SEGRO are seeking to increase the amount of site-wide mezzanine floor space that can be delivered at Northampton Gateway SRFI by 1.2 million sqft (111,480 sqm).

#### Assessment of mezzanine floor space

- 3.3 Mezzanine floor space does not generate trips on a pro-rata basis with conventional floor space and it is appropriate that the mezzanine floor space is not treated in a conventional way in terms of trip generation.
- 3.4 This is because mezzanines are typically introduced to enhance access to existing high-level storage areas, or to house automated operations. In each case, these functions do not result in a pro-rata increase in staff numbers compared to conventional floor space. The former, because, in the absence of mezzanine levels, high-level storage is typically used to access the warehouse space. The latter because automated operations are less staff intensive.
- 3.5 The employment densities for B8 uses given in the Homes and Communities Agency's (HCA) employment density guide (3rd edition 2015) are based on gross external area (GEA) and not GFA<sup>3</sup>. The GEA of a unit is not influenced by mezzanine floor space and therefore this supports the above position that mezzanine levels do not result in a pro-rata increase in staff.
- 3.6 Importantly, HGV generations are typically related to the number of loading bays, which are located on the ground floor and hence do not increase when mezzanine levels are introduced. Therefore, whilst the mezzanine levels may include automated operations which could improve efficiency and HGV throughput, there would not be a pro-rata increase in HGV numbers as these would be restricted by the number of loading bays.
- 3.7 The principle that mezzanine floor space does not generate trips on a pro-rata basis with conventional floor space was accepted as part of the DCO for Northampton Gateway SRFI. The position agreed in the TA that supported the DCO was to account for mezzanine floor space as generating trips at 50% of the rate of conventional floor space.
- 3.8 This TA Addendum therefore adopts the 50% trip generation rate for mezzanine floor space that was agreed in the TA. This ensures consistency with that work.

#### Vehicle trip generation

- 3.9 The vehicle trip rates for B8 warehousing (not accounting for the Travel Plan) have been extracted from the Northampton Gateway TA and are given below.

---

<sup>3</sup> Employment Density Guide 3<sup>rd</sup> edition: November 2015. Homes and Communities Agency; page 29.

	DCO vehicle trip rates per 100 sqm B8 use								
	light vehicles			heavy vehicles			total vehicles		
	Arrive	Depart	Two-way	Arrive	Depart	Two-way	Arrive	Depart	Two-way
AM	0.128	0.014	0.142	0.024	0.022	0.046	0.152	0.036	0.188
PM	0.042	0.147	0.190	0.021	0.019	0.040	0.063	0.166	0.230
Daily	1.119	1.101	2.220	0.326	0.326	0.652	1.445	1.427	2.872

3.10 The proposed 111,480 sqm of additional mezzanine floor space is assessed as generating the following vehicle trips, based on the agreed vehicle trips rates, and applying the 50% mezzanine factor.

	traffic generation based on DCO B8 vehicle trip rates and 50% mezzanine factor (not accounting for Travel Plan and excluding reductions due to rail interaction)								
	light vehicles			heavy vehicles			total vehicles		
	arrive	depart	two-way	arrive	depart	two-way	arrive	depart	two-way
AM	71	8	79	13	12	26	85	20	105
PM	23	82	105	12	11	22	35	93	128
Daily	624	614	1237	182	182	363	805	795	1601

3.11 No account of the potential interaction with the rail terminal has been made, and hence this further represents a robust position.

3.12 Northampton Gateway SRFI was assessed as generating 1,044 two-way vehicle trips in the morning peak hour, 1,303 two-way vehicle trips in the evening peak hour, and 16,531 vehicle trips over a 24-hour period.

3.13 The proposal to increase the mezzanine floor space allowance at the SRFI site could increase the off-site vehicle trips by 105 two-way trips in the morning peak hour, 128 two-way vehicle trips in the evening peak hour, and 1,601 vehicle trips over a 24-hour period. This equates to a 10% increase in off-site traffic.

### Person trip generation

3.14 The Public Transport Strategy, car share, and the pedestrian and cyclist strategy for the Northampton Gateway SRFI site were designed to positively influence the modal share to limit traffic generation. The Framework Travel Plan<sup>4</sup> sets the following modal share targets for the Northampton Gateway SRFI site. The occupiers are required to develop their own detailed Travel Plan in accordance with the requirements of the Framework Travel Plan.

mode	year 1	year 5
single occupancy vehicle	92%	74%
car share	5%	12%
public transport	3%	10%
walking and cycling	0%	4%

3.15 The Framework Travel Plan has the following modal share targets:

- Achieve a 20% reduction in single occupancy car journeys within 5 years
- 12% of employees to car share within 5 years
- 10 of employees trips to be made by bus within 5 years
- 3% of employee trips to be made by bike and 1% by foot within 5 years.

<sup>4</sup> Northampton Gateway Strategic Rail Freight Interchange, Framework Travel Plan, Version 2.7 Feb 2018, ITP ([planninginspectorate.gov.uk](http://planninginspectorate.gov.uk))

3.16 Based on the above modal share targets, and the assessment of the light vehicle trips given at paragraph 3.10 (as HGV trips would not undergo a modal shift, as their primary purpose is the transportation of their cargo), the tables below summarises the forecast daily, morning and evening peak hour, person trips that could be associated with the proposed additional mezzanine floor space at Northampton Gateway SRFI upon opening, and after 5 years.

summary of daily person trips by mode (based on agreed DCO trip rates)				
mode	year 1		year 5 target	
	arrive	depart	arrive	depart
car driver	624	614	502	494
hgv driver	182	182	182	182
car share	34	33	81	80
public transport	20	20	68	67
walking/cycling	0	0	27	27
<b>total</b>	<b>860</b>	<b>849</b>	<b>860</b>	<b>849</b>

summary of AM peak hour person trips by mode (based on agreed DCO trip rates)				
mode	year 1		year 5 target	
	arrive	depart	arrive	depart
car driver	71	8	57	6
hgv driver	13	12	13	12
car share	4	0	9	1
public transport	2	0	8	1
walking/cycling	0	0	3	0
<b>total</b>	<b>91</b>	<b>21</b>	<b>91</b>	<b>21</b>

summary of PM peak hour person trips by mode (based on agreed DCO trip rates)				
mode	year 1		year 5 target	
	arrive	depart	arrive	depart
car driver	23	82	19	66
hgv driver	12	11	12	11
car share	1	4	3	11
public transport	1	3	3	9
walking/cycling	0	0	1	4
<b>total</b>	<b>37</b>	<b>100</b>	<b>37</b>	<b>100</b>

3.17 The Travel Plan would reduce the overall traffic generation associated with Northampton Gateway SRFI. However, no Travel Plan deduction was applied to the traffic generations assessed in the approved TA. Accordingly, the highway infrastructure implemented by Northampton Gateway is designed to accommodate the pre-Travel Plan traffic generations.

3.18 To consider a robust position, and provide consistency with the TA, the following sections of this TA Addendum therefore consider the impact of the additional highway trips generated by the mezzanine floor space on the highway infrastructure without considering the impact of the Travel Plan.

## 4.0 TRIP DISTRIBUTION AND ASSIGNMENT

### Vehicle trip distribution

4.1 The vehicle trip distributions established for the light vehicle trips and HGV trips for the Northampton Gateway SRFI scheme have been extracted from the approved TA. These are summarised at **Diagrams 1 and 2**.

### Vehicle trip assignment

4.2 The vehicle trip generations for the additional mezzanine floor space given at paragraph 3.10 have been assigned to the highway network in accordance with the above distributions.

4.3 The resultant traffic flow assignment for the additional mezzanine floor space is shown at **Diagrams 3 and 4** for the morning and evening peak hours and is summarised in the table below.

traffic due to increased mezzanine floor space - AM peak hour total vehicles					
	A45	M1 south	A508 (btw site and M1 J15)	M1 north	A508 south of site
arrival	32	22	73	18	12
departure	9	5	18	5	2
<b>two-way</b>	<b>41</b>	<b>27</b>	<b>91</b>	<b>23</b>	<b>14</b>
traffic due to increased mezzanine floor space - PM peak hour total vehicles					
	A45	M1 south	A508 (btw site and M1 J15)	M1 north	A508 south of site
arrival	14	6	30	10	5
departure	46	19	81	16	12
<b>two-way</b>	<b>60</b>	<b>25</b>	<b>111</b>	<b>26</b>	<b>17</b>

## 5.0 ASSESSMENT OF IMPACTS

### Introduction

- 5.1 As shown in Section 4, the traffic associated with the additional mezzanine floor space would quickly disburse the highway network, with less than 30 two-way vehicle trips on the A508 to the south of the site, and only modest increases in traffic on the M1 and A45 approaches to M1 Junction 15.
- 5.2 Therefore, the study area for this TA Addendum has been limited to the A508 site access roundabout and M1 Junction 15.

### Assessment flows

- 5.3 The 2031 morning and evening peak hour future traffic flows with the SRFI and highway works in place (flow set J1d) have been extracted from the approved TA that was prepared to support the DCO. For the purposes of this TA Addendum these are the background traffic flows. They are summarised at **Diagrams 5 and 6** for the AM and PM peak hours.
- 5.4 The 2031 total traffic flows (with the traffic from the additional mezzanine floor space) have been derived by adding the traffic associated with the mezzanine floor space (**Diagrams 3 and 4**) to the 2031 background traffic flows. The resultant 2031 total traffic flows are summarised at **Diagrams 7 and 8** for the AM and PM peak hours.

### A508 site access roundabout

- 5.5 The TA submitted in support of the DCO application demonstrated that the A508 northbound and southbound approaches to the site access roundabout were forecast to operate at 85% and 82% of their full capacity by 2031, with the Northampton Gateway SRFI fully operational.
- 5.6 A ratio of flow to capacity of 0.85 (85%) is often considered to be the upper design capacity threshold. The increase in traffic flow due to an increase in the mezzanine floor space would cause the A508 northbound approach to operate above 85% of capacity and could also push the A508 southbound approach above 85%.
- 5.7 Therefore, to facilitate an increase in the amount of permitted mezzanine floor space, an improvement scheme would be required to provide additional capacity at the site access junction and ensure its continued efficient operation.
- 5.8 Factors effecting the options to provide additional capacity at the site access roundabout are summarised as follows:
- Most of the development traffic arrives/departs to/from the north via M1 Junction 15.
  - A segregated left-turn lane on the site access arm means that northbound traffic exiting the SRFI does not enter the roundabout. The site access arm of the roundabout is therefore relatively lightly trafficked and does not require capacity enhancement.
  - The A508 northbound approach handles only around 20% of the development traffic arrivals but is opposed by the large right-turn flow arriving at the site from the north. Hence, this arm operates at capacity in the morning peak hour when the right-turn volume is greatest.
  - Improving the capacity of the A508 northbound approach would require significant carriageway widening.

- The A508 southbound approach to the roundabout has two full lanes and a flared offside lane and there is a staggered puffin crossing set back from the roundabout. This approach operates acceptably in both the morning and evening peak hours, though at 82%, it is approaching 85% of its capacity in the morning peak hour.

5.9 Following an iterative design and modelling exercise, the optimum solution was found to be upgrading the A508 southbound approach to traffic signal control on the entry and circulating carriageway. The preliminary layout of the proposed scheme<sup>5</sup> is shown at **Figure 7**.

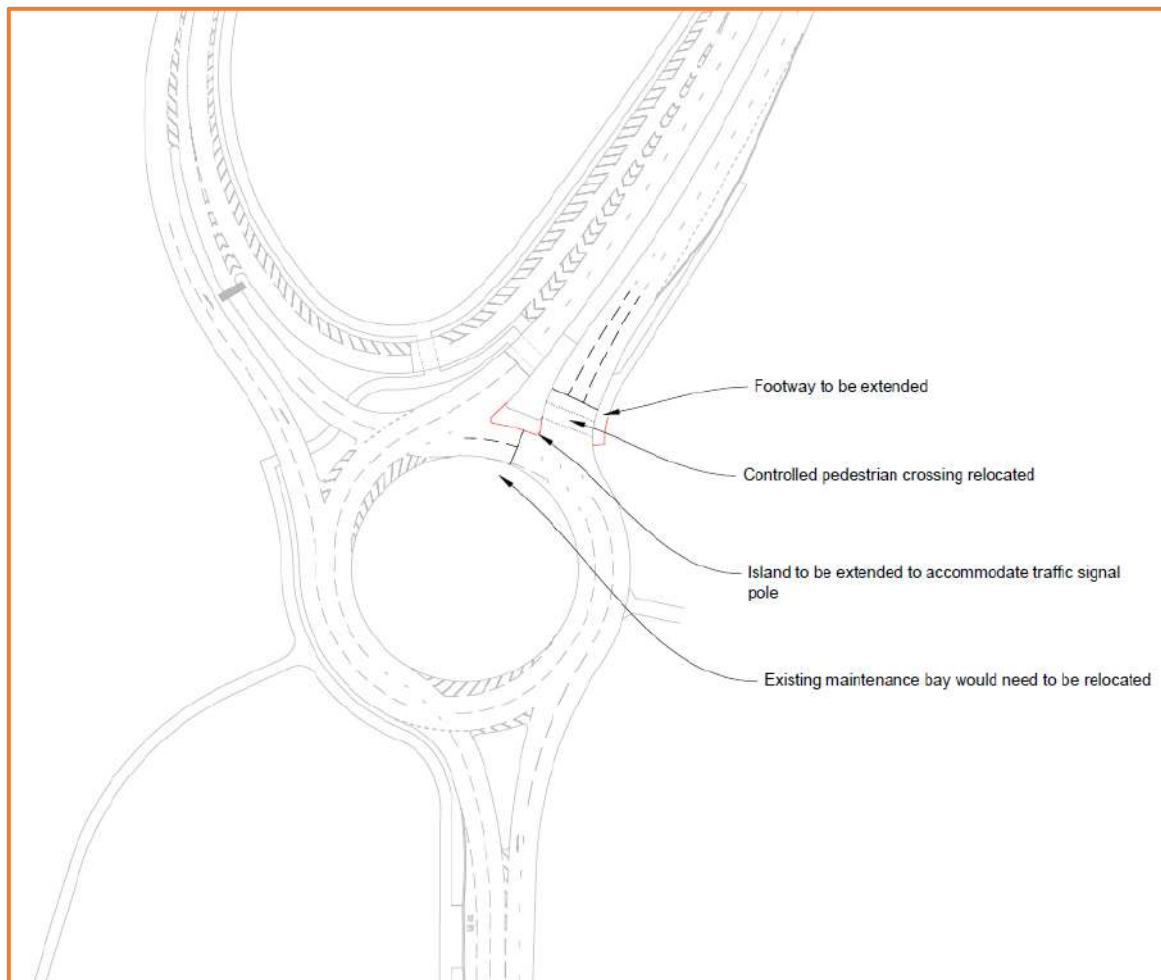

Figure 7: proposed partial signalisation of the A508 site access junction

5.10 This option was selected for the following reasons:

- Providing traffic signals on the A508 southbound arm significantly increases capacity on this approach.
- Signalising the A508 southbound approach creates gaps in the right-turning traffic into the site of 20 seconds, allowing traffic on the A508 northbound approach to enter the roundabout more easily, materially improving capacity without the need for improvement works on the A508 northbound approach.
- No carriageway widening on the A508 southbound approach would be required.
- The A508 southbound puffin crossing would effectively be relocated south so that it was at the roundabout, allowing some traffic signals equipment to be reused.
- The puffin crossing on the northbound exit from the roundabout could remain in its current location.

<sup>5</sup> Subject to agreement of the proposed scheme in principle with the local highway authority, a full drawing pack will be prepared for submission with the DCO amendment.

5.11 The operation of the site access junction has been modelling using LinSig. The modelling output is provided at the results in **Appendix B** and a summary of the results is provided at the table below.

Number	Scenario Name	Flow Group	Time	Cycle Time (s)	PRC (%)	Delay (pcuHr)
1	2031 with additional mez - AM	2031 with additional mez - AM	08:00 - 09:00	60	6.1	12.06
2	2031 with additional mez - PM	2031 with additional mez - PM	17:00 - 18:00	60	19.4	8.59

5.12 The modelling demonstrates that the junction would operate with positive practical reserve capacity (PRC) in both the morning and evening peak hours in the 2031 assessment year with the mezzanine additional floor space in place.

### M1 Junction 15

5.13 The highway improvement scheme at M1 Junction 15 was designed to provide a better than nil detriment improvement with the forecast 2031 background traffic + SRFI traffic than when compared to the previous arrangement of the junction, without the SRFI traffic. The detailed junction modelling showed that the total delay at the junction would reduce by more than 50% in both peak hours, with capacity improvements on all approaches to the junction.

5.14 However, despite the significant improvements provided, in the 2031 assessment year the junction was still forecast to operate above 100% of its capacity in the morning peak hour and below 100% of its capacity in the evening peak hour.

5.15 The controller configuration for the as-built junction improvement scheme was provided by National Highways so that the approved LinSig model could be updated to reflect the changes made to the scheme during the detailed design and implementation phases. As a result, the phase and stage arrangement and the intergreen matrices have been updated to match the controller function on-street.

5.16 The operation of the junction has been assessed using the updated LinSIG. The modelling output is provided at the results in **Appendix C** and a summary of the results is provided at the table below.

Number	Scenario Name	Flow Group	Time	Cycle Time (s)	PRC (%)	Delay (pcuHr)
1	2031 Background - AM	2031 background - AM	08:00 - 09:00	80	-22.9	325.33
2	2031 With additional mez - AM	2031 with additional mez - AM	08:00 - 09:00	80	-22.9	344.28
3	2031 Background - PM	2031 background - PM	17:00 - 18:00	76	-11.5	133.03
4	2031 With additional mez - PM	2031 with additional mez - PM	17:00 - 18:00	76	-11.5	134.52

5.17 The results show that there would be no material deterioration in the practical reserve capacity at the junction. Whilst there would be increases in delay and queueing across the model, these could not be categorised as severe. The junction would continue to operate significantly better than without the SRFI traffic and associated highway improvements.

### **Impact of additional person trips**

- 5.18 The accessibility of the site for pedestrians, cyclists, and public transport users is discussed at Section 2 of this TA Addendum.
- 5.19 As described, as part of the DCO for the Northampton Gateway, walking and cycling strategies were put in place both within the development and off-site on the highway network, including new and improved infrastructure, to provide connectivity from the SRFI site to Collingtree, Northampton, and Roade.
- 5.20 The public transport strategy for the SRFI site includes the introduction of a new bus service specifically serving the SRFI site, as well as building on the existing local bus network and providing additional bus stops on the A508 to the north and south of the A508/site access roundabout, giving access to the 33/33A and the X6 services.
- 5.21 The Northampton Gateway SRFI development will provide internal pedestrian and cyclists routes through the site, together with improved connections and complementary improvements to the external networks.
- 5.22 As assessed at Section 3, the additional mezzanine floor space could generate up to 11 additional public transport trips, and five additional walking and cycling trips during a peak hour period. These additional trips would be satisfactorily accommodated by the consented infrastructure improvements associated with the DCO. Therefore, no further assessment of the impacts of the person trips generated by the mezzanine floor space is required.

## 6.0 SUMMARY AND CONCLUSIONS

- 6.1 SEGRO Plc have commissioned ADC Infrastructure Ltd to prepare this Transport Assessment (TA) Addendum to support an application to amend the Development Consent Order (DCO) for their Northampton Gateway Strategic Rail Freight Interchange (SRFI) development.
- 6.2 The amendment to the DCO is required in response to changes in market demand, as occupiers now require much greater volumes of mezzanine floor space than was previously the case. SEGRO are therefore seeking to amend the maximum amount of mezzanine floor space that is permitted under the DCO. This will safeguard the future build out of the SRFI site by ensuring that it can provide an appropriate mix of floor space and hence remain attractive to occupiers.
- 6.3 SEGRO are seeking to increase the amount of site wide mezzanine floor space that can be delivered at Northampton Gateway SRFI by 1.2 million sqft (111,480 sqm).
- 6.4 The principle that Northampton Gateway SRFI is a suitable location for B8 employment use was established as part of the DCO for the scheme. This is reinforced by West Northamptonshire Council's New Local Plan Regulation 18 document, which puts forward the land adjacent to Northampton Gateway SRFI as suitable for B8 development.
- 6.5 As part of the DCO for Northampton Gateway, a comprehensive package of highway mitigation measures is approved and consented. The highway improvement measures include a major upgrade to M1 Junction 15 and the A45, improvements to M1 Junction 15A, a bypass for the village of Roade, the implementation of environmental weight restrictions, improvements along the A508 as part of the A508 route upgrade, and financial contributions towards improvements to the A45 Queen Eleanor Interchange, and junctions along the A5076, and a Knock Lane and Blisworth Road maintenance and minor works fund.
- 6.6 The construction of the offsite highway works commenced in 2021. Except for works on the A508 associated with the access to the Courteenhall Estate, all the highway improvements are complete and open to traffic.
- 6.7 Walking and cycling strategies were developed in agreement with the highway authorities as part of the DCO. These are in the process of being put in place both within the development and off-site on the highway network, to provide enhanced connectivity from the SRFI site for pedestrians and cyclists to Collingtree, Northampton, and Roade.
- 6.8 The internal and external footway/cycleway network provides significantly improved connections to the residential areas within the walking and cycling catchments and therefore, there are direct and safe walking and cycling routes to and from the SRFI.
- 6.9 As part of the DCO, a public transport strategy was developed which includes the introduction of a new bus service specifically serving the SRFI site, as well as building on the existing local bus network and providing additional bus stops on the A508 to the north and south of the A508/site access roundabout.
- 6.10 An assessment of the additional trips that could be generated by the additional mezzanine floor space has been undertaken using the trip rates agreed as part of the TA. The proposal to increase the mezzanine floor space allowance at the SRFI site could increase the off-site vehicle trips by 105 two-way trips in the morning peak hour and 128 two-way vehicle trips in the evening peak hour. The additional mezzanine floor space could generate up to 11 additional public transport trips, and five additional walking and cycling trips during a peak hour period. The assessment of

the traffic impact has not considered the beneficial effect of Travel Plan in reducing vehicle trips and therefore represent a robust position.

- 6.11 The impact of the additional trips on transport infrastructure has been assessed. Subject to an improvement scheme at the SRFI site access roundabout on the A508, it is concluded that the transport impacts arising of the increased mezzanine floor space would continue to be mitigated by the infrastructure improvements consented and delivered as part of the DCO, with residual impacts reduced to acceptable levels. Accordingly, there should be no objection to the proposed amendment to the DCO.

## DIAGRAMS

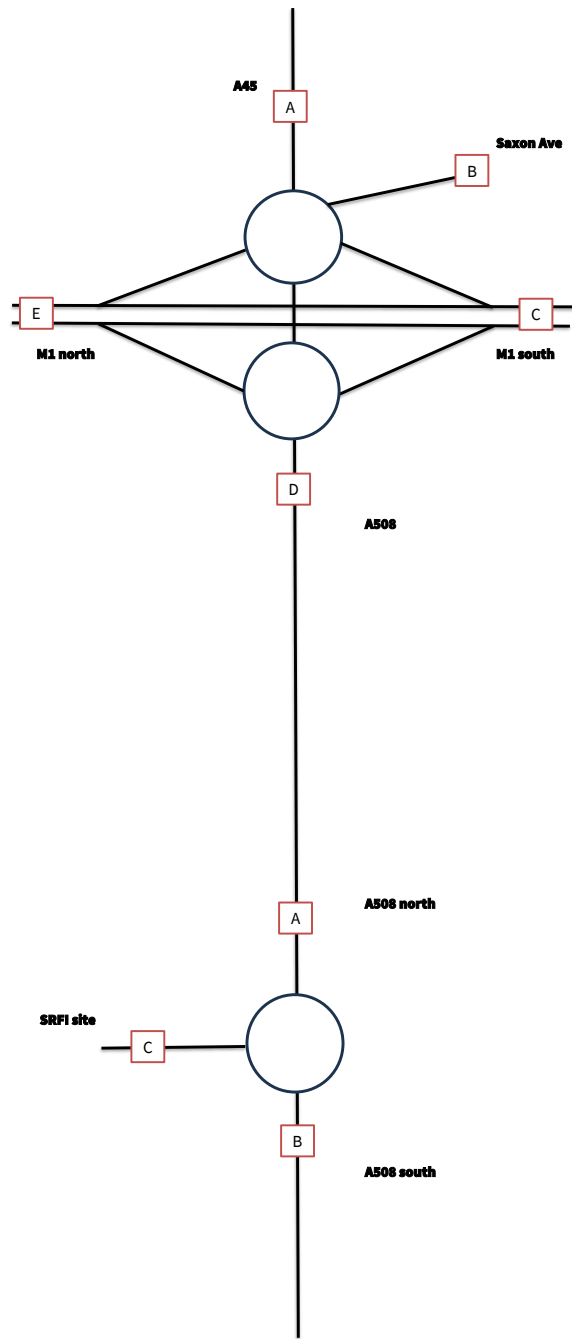

Light Vehicles						
	A	B	C	D	E	Total
A				38%		38%
B				0%		0%
C				26%		26%
D	51%	0%	14%	0%	17%	82%
E				21%		21%
Total	51%	0%	14%	85%	17%	

HGVs						
	A	B	C	D	E	Total
A				36%		36%
B				0%		0%
C				29%		29%
D	40%	0%	32%	0%	29%	100%
E				26%		26%
Total	40%	0%	32%	91%	29%	

Light Vehicles				
	A	B	C	Total
A			85%	85%
B			15%	15%
C	81%	19%		100%
Total	81%	19%	100%	

HGVs				
	A	B	C	Total
A			91%	91%
B			9%	9%
C	100%	0%		100%
Total	100%	0%	100%	

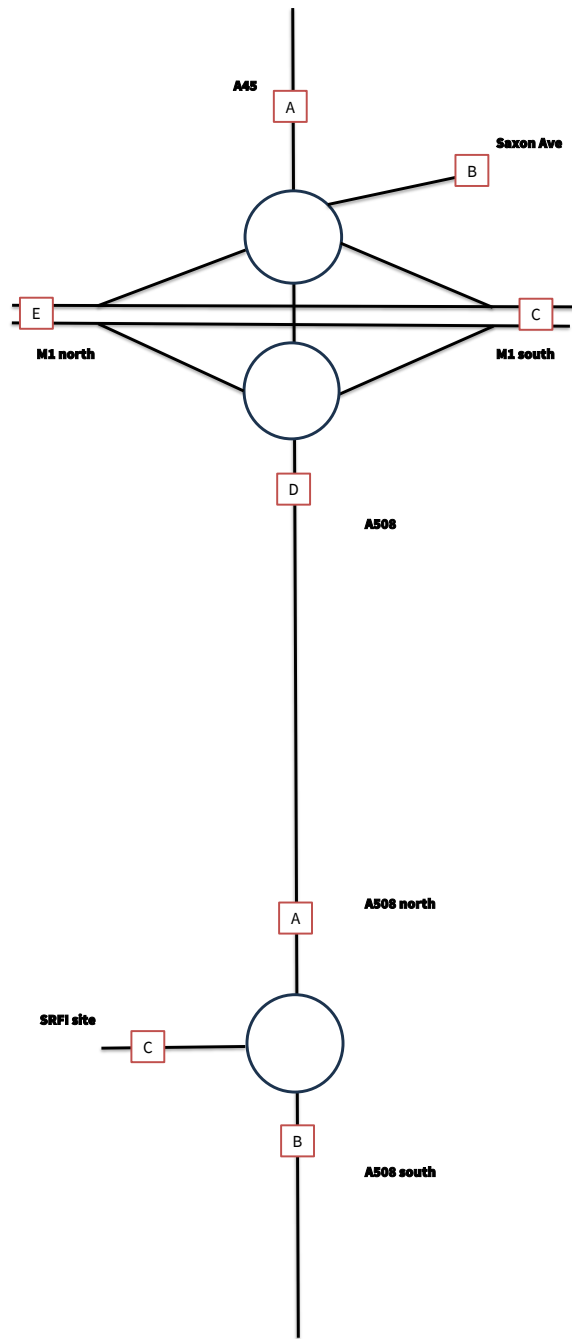

Light Vehicles						
	A	B	C	D	E	Total
A				44%		44%
B				0%		0%
C				11%		11%
D	51%	0%	19%	0%	16%	86%
E				28%		28%
<b>Total</b>	<b>51%</b>	<b>0%</b>	<b>19%</b>	<b>82%</b>	<b>16%</b>	

HGVs						
	A	B	C	D	E	Total
A				36%		36%
B				0%		0%
C				29%		29%
D	40%	0%	32%	0%	29%	100%
E				26%		26%
<b>Total</b>	<b>40%</b>	<b>0%</b>	<b>32%</b>	<b>91%</b>	<b>29%</b>	

Light Vehicles				
	A	B	C	Total
A			82%	82%
B			18%	18%
C	86%	14%		100%
<b>Total</b>	<b>86%</b>	<b>14%</b>	<b>100%</b>	

HGVs				
	A	B	C	Total
A			91%	91%
B			9%	9%
C	100%	0%		100%
<b>Total</b>	<b>100%</b>	<b>0%</b>	<b>100%</b>	

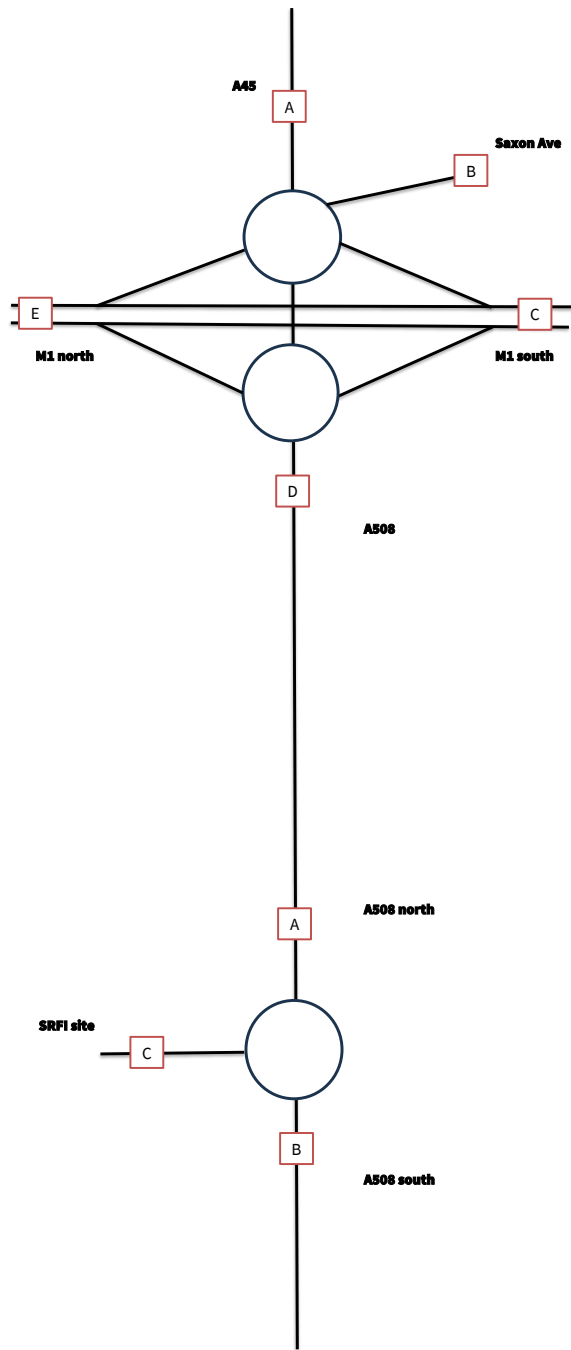

Light Vehicles						
	A	B	C	D	E	Total
A				27		27
B				0		0
C				19		19
D	4	0	1	0	1	6
E				15		15
<b>Total</b>	<b>4</b>	<b>0</b>	<b>1</b>	<b>61</b>	<b>1</b>	<b>67</b>

HGVs						
	A	B	C	D	E	Total
A				5		5
B				0		0
C				4		4
D	5	0	4	0	4	12
E				3		3
<b>Total</b>	<b>5</b>	<b>0</b>	<b>4</b>	<b>12</b>	<b>4</b>	<b>24</b>

Total Vehicles						
	A	B	C	D	E	Total
A				32		32
B				0		0
C				22		22
D	9	0	5	0	5	19
E				18		18
<b>Total</b>	<b>9</b>	<b>0</b>	<b>5</b>	<b>73</b>	<b>5</b>	<b>91</b>

PCUs						
	A	B	C	D	E	Total
A				38		38
B				0		0
C				27		27
D	15	0	10	0	9	35
E				23		23
<b>Total</b>	<b>15</b>	<b>0</b>	<b>10</b>	<b>89</b>	<b>9</b>	<b>123</b>

Light Vehicles				
	A	B	C	Total
A				61
B				11
C	6	2		8
<b>Total</b>	<b>6</b>	<b>2</b>	<b>71</b>	<b>79</b>

HGVs				
	A	B	C	Total
A				12
B				1
C	12	0		12
<b>Total</b>	<b>12</b>	<b>0</b>	<b>13</b>	<b>26</b>

Total Vehicles				
	A	B	C	Total
A				73
B				12
C	18	2		20
<b>Total</b>	<b>18</b>	<b>2</b>	<b>85</b>	<b>105</b>

PCUs				
	A	B	C	Total
A				89
B				13
C	35	2		36
<b>Total</b>	<b>35</b>	<b>2</b>	<b>102</b>	<b>138</b>

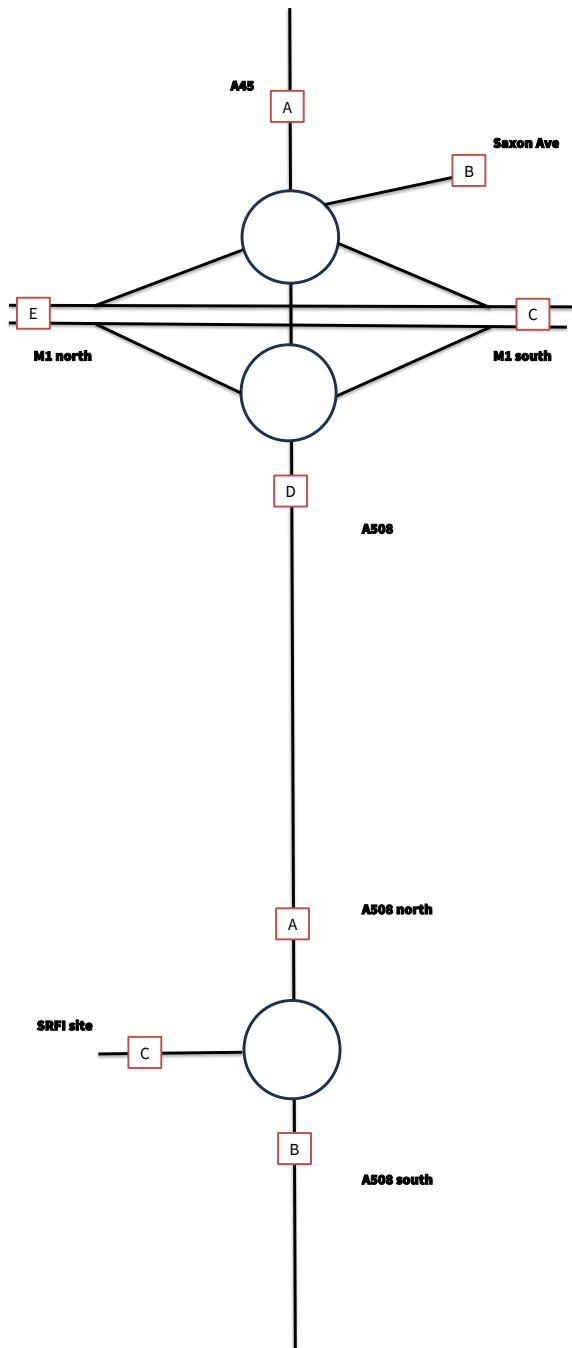

Light Vehicles						
	A	B	C	D	E	Total
A				10		10
B				0		0
C				3		3
D	42	0	16	0	13	70
E				7		7
<b>Total</b>	<b>42</b>	<b>0</b>	<b>16</b>	<b>20</b>	<b>13</b>	<b>90</b>

HGVs						
	A	B	C	D	E	Total
A				4		4
B				0		0
C				3		3
D	4	0	3	0	3	11
E				3		3
<b>Total</b>	<b>4</b>	<b>0</b>	<b>3</b>	<b>11</b>	<b>3</b>	<b>21</b>

Total Vehicles						
	A	B	C	D	E	Total
A				14		14
B				0		0
C				6		6
D	46	0	19	0	16	81
E				10		10
<b>Total</b>	<b>46</b>	<b>0</b>	<b>19</b>	<b>30</b>	<b>16</b>	<b>111</b>

PCUs						
	A	B	C	D	E	Total
A				20		20
B				0		0
C				10		10
D	51	0	23	0	20	95
E				14		14
<b>Total</b>	<b>51</b>	<b>0</b>	<b>23</b>	<b>44</b>	<b>20</b>	<b>139</b>

Light Vehicles				
	A	B	C	Total
A			19	19
B			4	4
C	70	12		82
<b>Total</b>	<b>70</b>	<b>12</b>	<b>23</b>	<b>105</b>

HGVs				
	A	B	C	Total
A			11	11
B			1	1
C	11	0		11
<b>Total</b>	<b>11</b>	<b>0</b>	<b>12</b>	<b>22</b>

Total Vehicles				
	A	B	C	Total
A			30	30
B			5	5
C	81	12		93
<b>Total</b>	<b>81</b>	<b>12</b>	<b>35</b>	<b>128</b>

PCUs				
	A	B	C	Total
A			44	44
B			7	7
C	95	12		106
<b>Total</b>	<b>95</b>	<b>12</b>	<b>50</b>	<b>157</b>

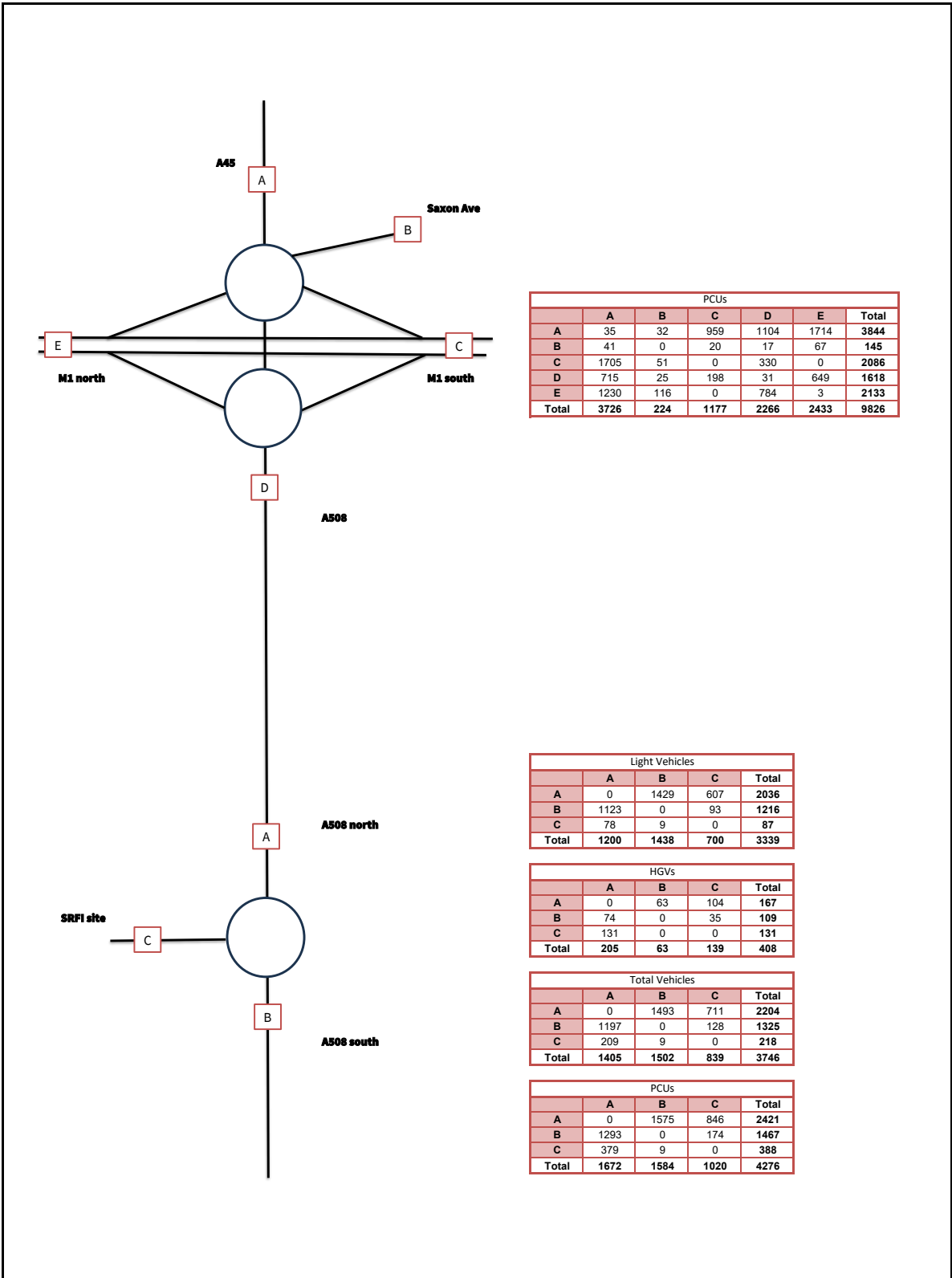

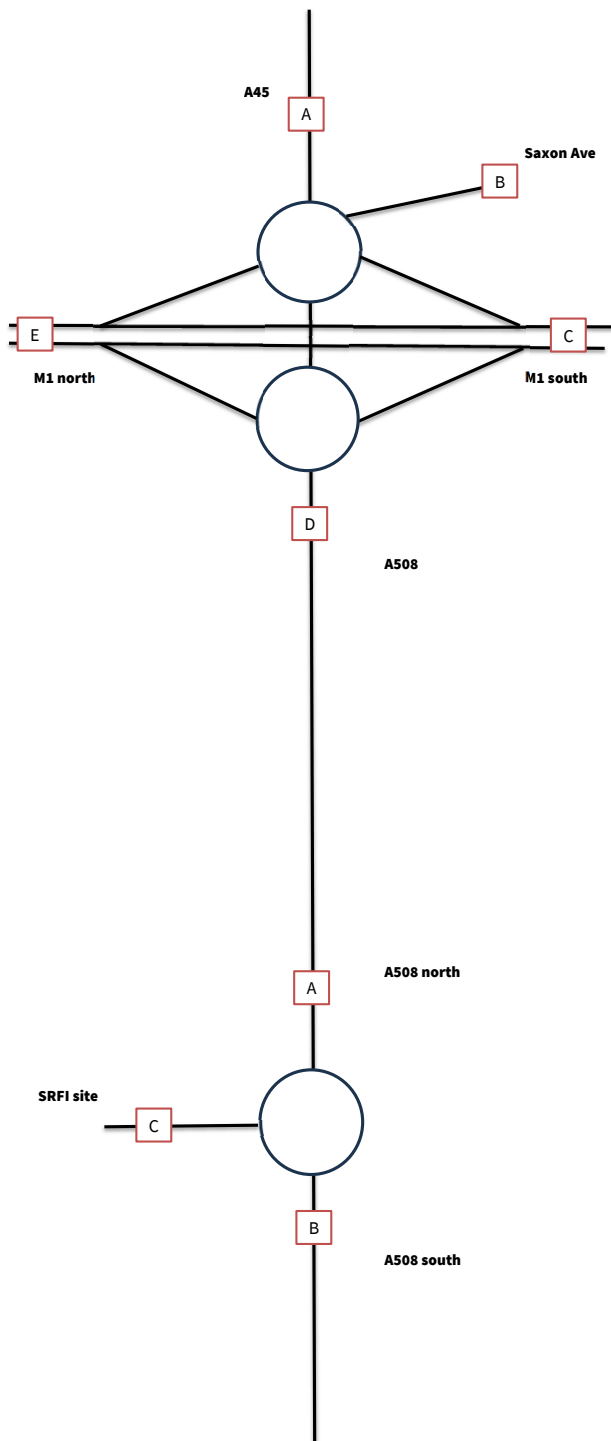

PCUs						
	A	B	C	D	E	Total
A	117	88	985	1199	1279	3668
B	30	0	121	18	100	269
C	1503	25	0	205	0	1733
D	1440	13	199	50	709	2411
E	1007	99	0	563	0	1669
Total	4097	225	1305	2035	2088	9750

Light Vehicles				
	A	B	C	Total
A	0	1466	205	1671
B	1202	0	25	1227
C	734	70	0	804
Total	1936	1535	230	3702

HGVs				
	A	B	C	Total
A	0	80	109	189
B	47	0	30	77
C	131	0	0	131
Total	178	80	139	398

Total Vehicles				
	A	B	C	Total
A	0	1546	314	1860
B	1249	0	55	1304
C	865	70	0	935
Total	2115	1616	369	4099

PCUs				
	A	B	C	Total
A	0	1651	456	2106
B	1311	0	94	1405
C	1035	70	0	1105
Total	2347	1720	550	4617

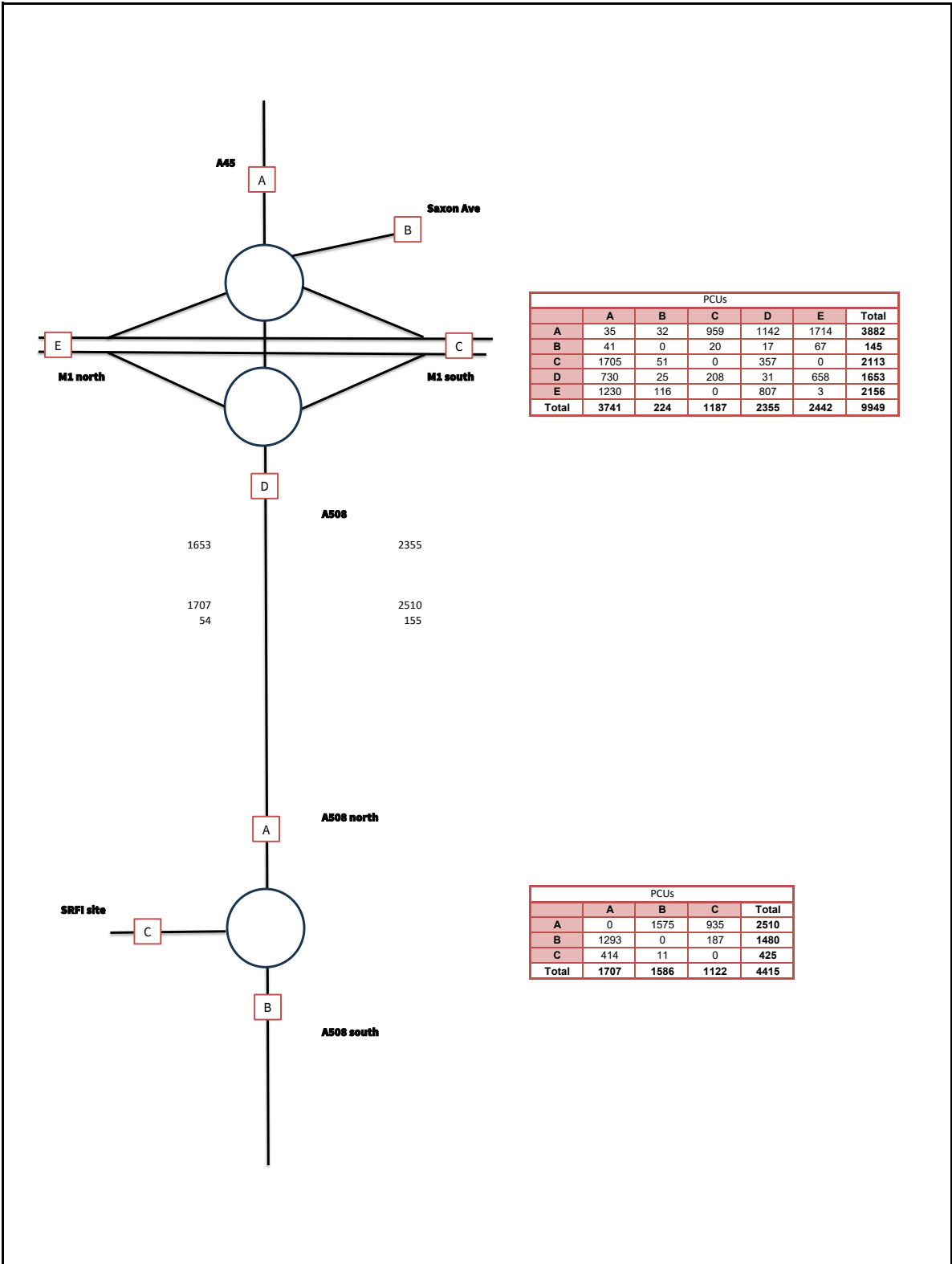

PCUs						
	A	B	C	D	E	Total
A	35	32	959	1142	1714	3882
B	41	0	20	17	67	145
C	1705	51	0	357	0	2113
D	730	25	208	31	658	1653
E	1230	116	0	807	3	2156
Total	3741	224	1187	2355	2442	9949

PCUs				
	A	B	C	Total
A	0	1575	935	2510
B	1293	0	187	1480
C	414	11	0	425
Total	1707	1586	1122	4415

Diagram 7: 2031 total traffic flows - AM peak hour

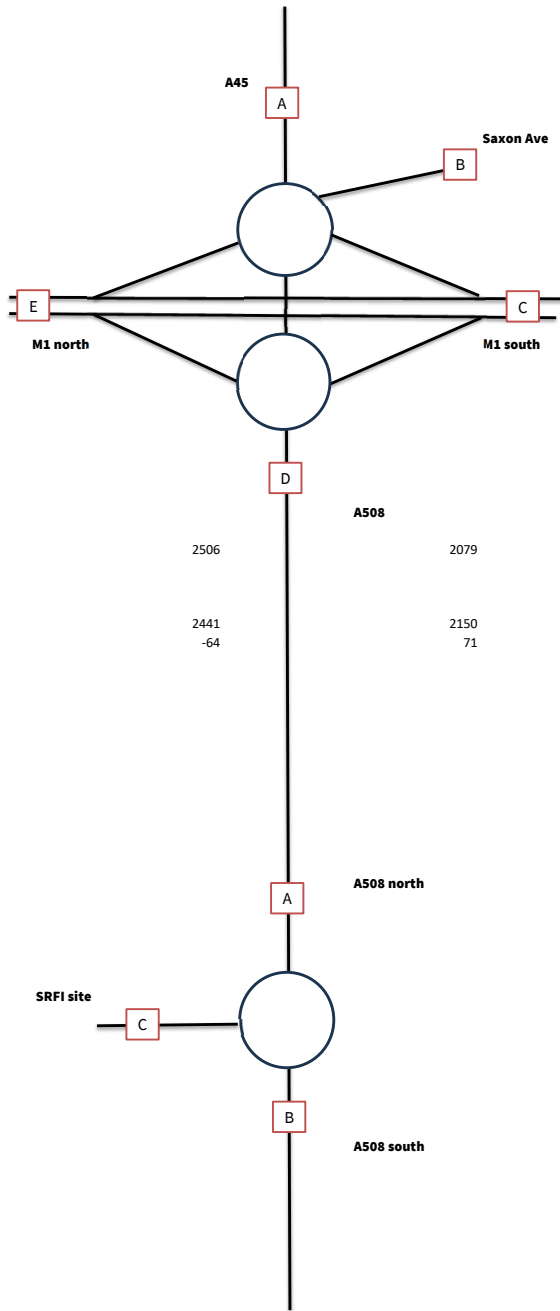

PCUs						
	A	B	C	D	E	Total
A	117	88	985	1219	1279	3688
B	30	0	121	18	100	269
C	1503	25	0	215	0	1743
D	1491	13	222	50	729	2506
E	1007	99	0	577	0	1683
Total	4148	225	1328	2079	2108	9889

2506  
2441  
-64

2079  
2150  
71

PCUs				
	A	B	C	Total
A	0	1651	499	2150
B	1311	0	101	1412
C	1130	81	0	1212
Total	2441	1732	600	4773

## APPENDIX A

# DCO PARAMETERS PLAN

**SCHEDULE OF PARAMETERS**

Zone	Number of Units	Maximum development floor space per Zone in m <sup>2</sup>	Minimum finished floor level (in m above ordnance datum)	Maximum building height measured to roof ridge / highest point (in metres above ordnance datum)
Zone A1 (a, b & c)	1 to 8	180,000	Zone A1a 81.50 Zone A1b 83.50 Zone A1c 84.00	104.00 104.00 104.00
Zone A2 (a & b)	1 to 4	152,000	Zone A2a 90.00 Zone A2b 89.50	109.50 109.50
Zone A3	1 to 4	55,000	89.00	109.50
Zone A4	1 to 4	126,000	88.50	109.00
<b>Maximum Total Floor Space Zone A*</b>				
<b>Total</b>	<b>1 to 20</b>	<b>468,000</b>		

Zone	Number of Units	Maximum development floor space per Zone in m <sup>2</sup>	Minimum finished ground level (in m above ordnance datum)	Maximum height measured to roof ridge / highest point (in metres above ordnance datum)
Zone B (Buildings)	1 to 4	1858	89.00	Buildings 103.00
(Yard)			89.00	Yard 105.00
(Cranes)			89.00	Gantry Cranes 110.50

\* this total floor space is the maximum floor space (excluding mezzanine space) that will be developed across Zone A notwithstanding that the maximum floor space stated for each Zone A1 to A4 combined would exceed this figure i.e. it is the overall floor space cap for Zone A excluding mezzanine floor space. In addition to this total floor space figure, up to 155,000 sqm (1,688,420 sqft) of floor space can be provided in the form of mezzanine floor space to units within Zone A

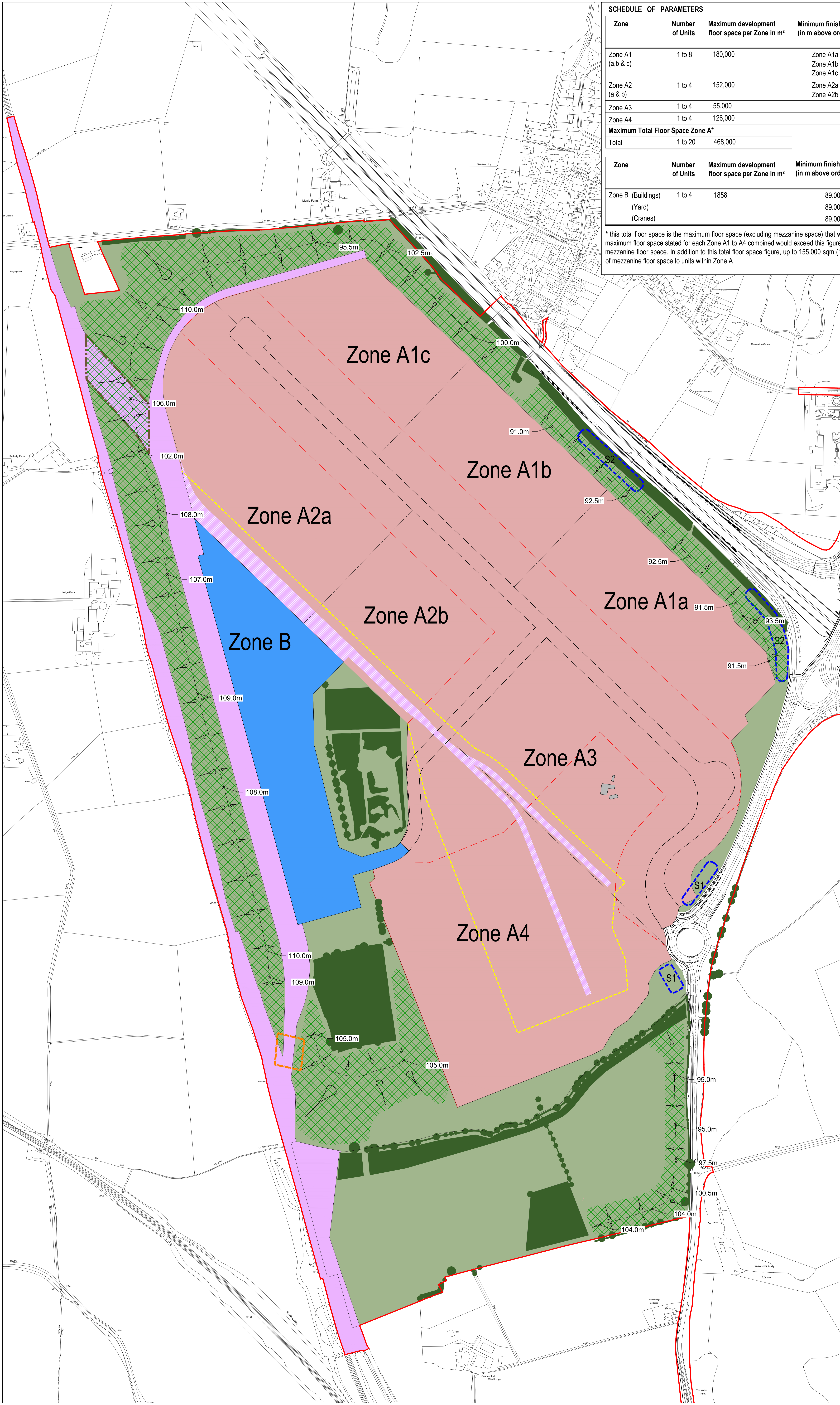

**LEGEND**

- Open Land / Landscaping including landscape screen bunding, attenuation ponds & retained agricultural land
- Existing woodland to be retained
- Estate roads
- Limits of deviation to Estate roads
- Rail corridor including new rail line and landscaping
- Rail corridor within development zones
- Limits of deviation to rail corridor within development zones
- Zone A development area
- Zone boundaries within development area
- Zone B rail freight interchange
- Order Limits
- S1 Area for development signage  
S1 = Sign Board max size (including supporting frame) 7.5m High x 18.3m Wide x 1.3m Deep
- S2 = Totem Sign max size (including supporting frame) 15.5m High x 4.0m Wide x 4.0m Deep
- Farm buildings to be demolished
- Areas within which strategic screen bunding is to be provided
- Fixed spot heights in metres above ordnance datum, identified along the ridgeline of each length of strategic screen bund
- 107.0m Between any two consecutive spot heights marked on the ridge, the height of the bund, at its ridge, will be no lower than the lower of the two spot heights and no higher than the higher of the two spot heights
- 108.0m
- Corridor for rail tunnel through strategic screen bunding
- Corridor for pedestrian footbridge over new rail line

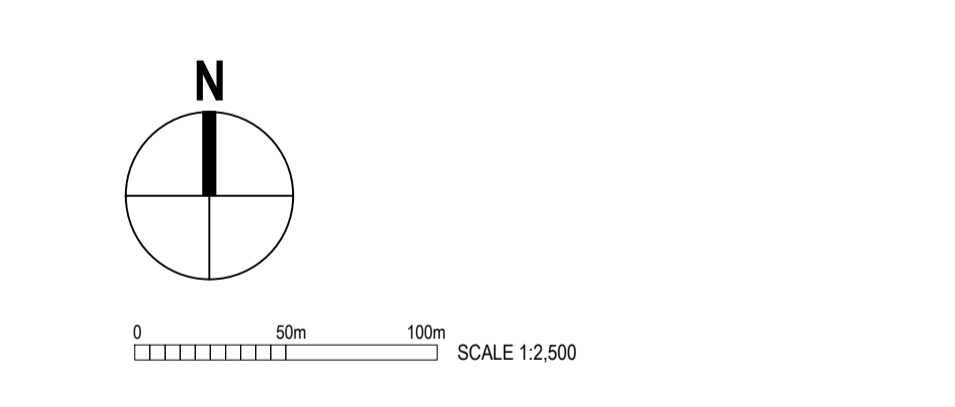

S2	11.02.2019	Rail tunnel corridor re-aligned, top of bund spot heights added	2.10	S2
Rev	Date	Details of issue / revision	Drawn	Rev

**ROXHILL**

**NORTHAMPTON GATEWAY**  
STRATEGIC RAIL FREIGHT INTERCHANGE

**THE NORTHAMPTON GATEWAY RAIL FREIGHT INTERCHANGE ORDER 201X**

**PARAMETERS PLAN**

Scale	1:2,500	Drawn	RM
Size	A0	Reviewed	SH
Regulation	Document		
<b>Reg 5(2)(o)</b>	<b>2.10</b>		
<b>Drawing Status</b>			
<b>SUBMISSION</b>			
Drawing No.	4054 - R007	Revision	S2

## APPENDIX B

# A508/SITE ACCESS LINSIG ASSESSMENT RESULTS

# Full Input Data And Results

## User and Project Details

Project:	A508 site access junction mitigation
Title:	
Location:	
Client:	Segro
Additional detail:	
File name:	240514 site access gyratory - proposed mitigation.lsg3x
Author:	Mark Higgins
Company:	ADC Infrastructure Ltd
Address:	Nottingham

## Network Layout Diagram

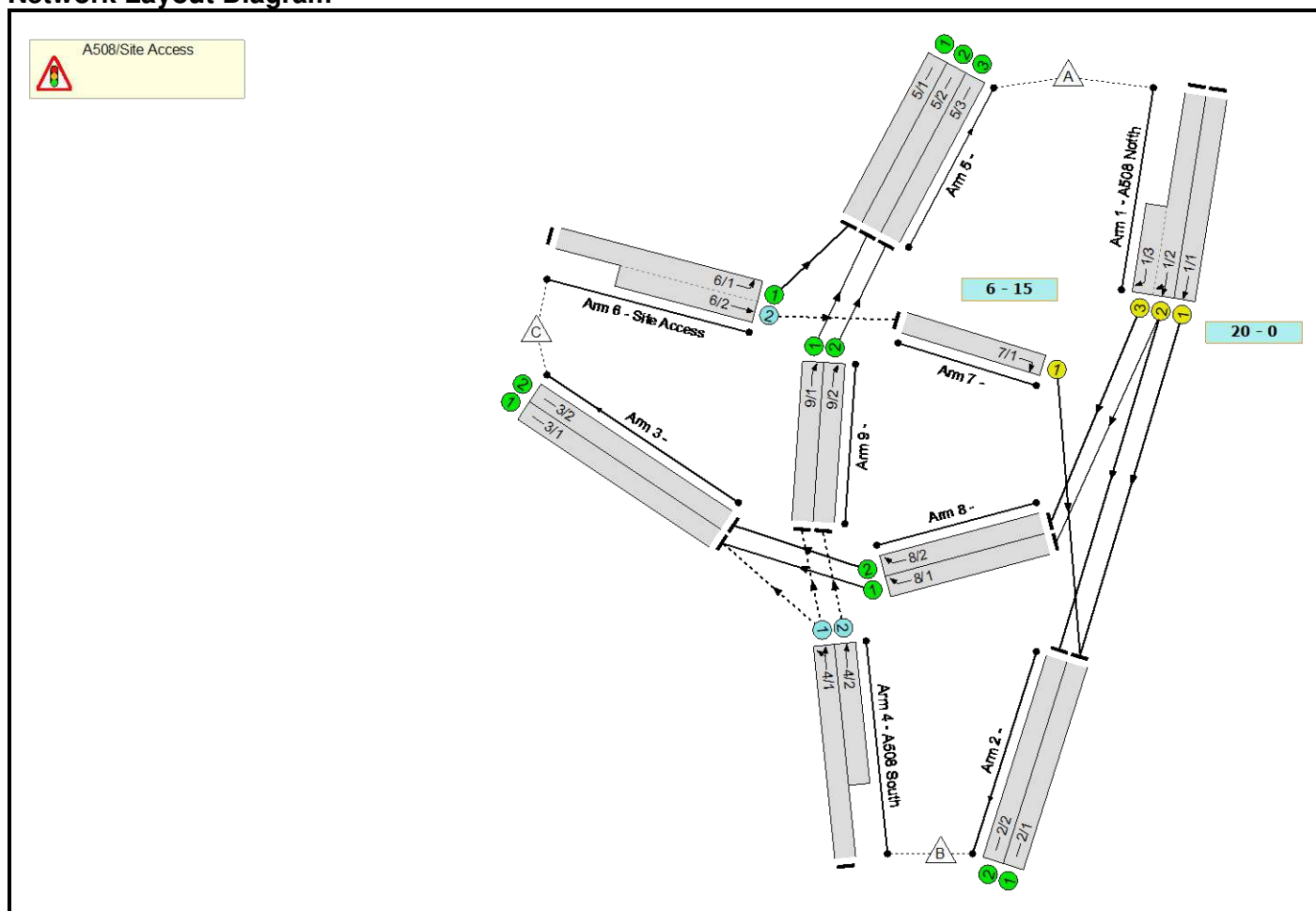

## Phase Diagram

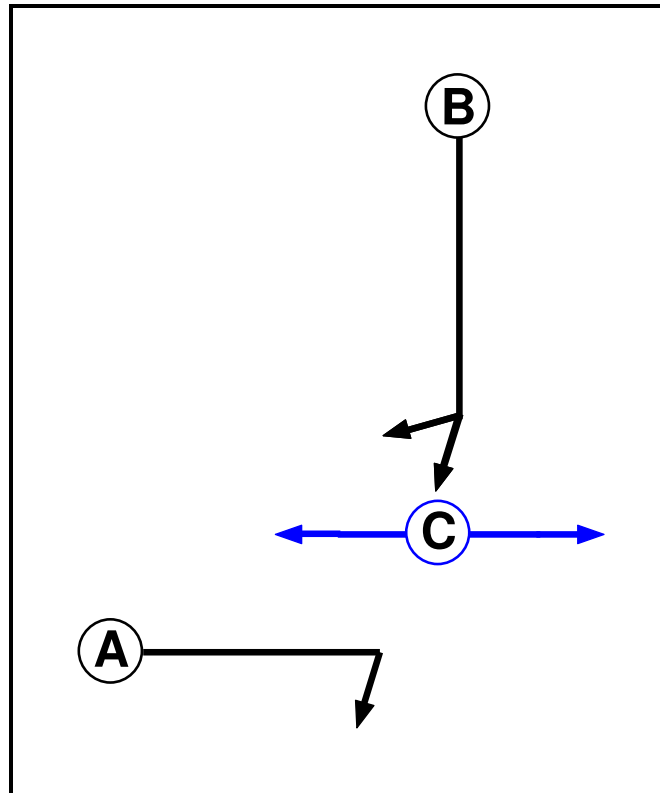

## Phase Input Data

Phase Name	Phase Type	Stage Stream	Assoc. Phase	Street Min	Cont Min
A	Traffic	1		7	4
B	Traffic	1		7	7
C	Pedestrian	1		6	6

## Phase Intergreens Matrix

	Starting Phase		
	A	B	C
Terminating Phase	A	5	-
	B	6	6
	C	-	8

## Phases in Stage

Stream	Stage No.	Phases in Stage
1	1	A C
1	2	B

### Stage Diagram

Stage Stream: 1

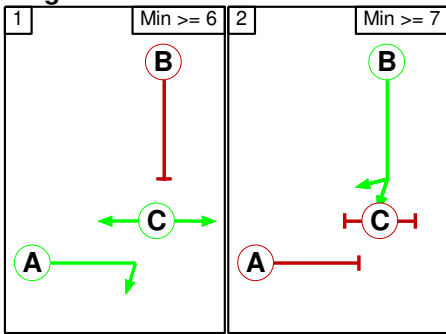

### Phase Delays

Stage Stream: 1

Term. Stage	Start Stage	Phase	Type	Value	Cont value
1	2	A	Losing	3	3

### Prohibited Stage Change

Stage Stream: 1

From Stage	To Stage	
	1	2
1		8
2	6	

### Give-Way Lane Input Data

Junction: A508/Site Access											
Lane	Movement	Max Flow when Giving Way (PCU/Hr)	Min Flow when Giving Way (PCU/Hr)	Opposing Lane	Opp. Lane Coeff.	Opp. Mvmnts.	Right Turn Storage (PCU)	Non-Blocking Storage (PCU)	RTF	Right Turn Move up (s)	Max Turns in Intergreen (PCU)
4/1 (A508 South)	3/1 (Left)	1106	0	8/1	0.25	All	-	-	-	-	-
				8/2	0.25	All					
4/2 (A508 South)	9/1 (Ahead)	1106	0	8/1	0.25	All	-	-	-	-	-
				8/2	0.25	All					
	9/2 (Ahead)	1106	0	8/1	0.25	All					
				8/2	0.25	All					
6/2 (Site Access)	7/1 (Ahead)	1000	0	9/1	0.33	All	-	-	-	-	-
				9/2	0.33	All					

## Lane Input Data

Junction: A508/Site Access												
Lane	Lane Type	Phases	Start Disp.	End Disp.	Physical Length (PCU)	Sat Flow Type	Def User Saturation Flow (PCU/Hr)	Lane Width (m)	Gradient	Nearside Lane	Turns	Turning Radius (m)
1/1 (A508 North)	U	B	2	3	60.0	Geom	-	3.65	0.00	Y	Arm 2 Ahead	22.00
1/2 (A508 North)	U	B	2	3	60.0	Geom	-	3.65	0.00	N	Arm 2 Ahead	25.00
1/3 (A508 North)	U	B	2	3	6.3	Geom	-	3.65	0.00	N	Arm 8 Right	25.00
2/1	U		2	3	60.0	Inf	-	-	-	-	-	-
2/2	U		2	3	60.0	Inf	-	-	-	-	-	-
3/1	U		2	3	60.0	Inf	-	-	-	-	-	-
3/2	U		2	3	60.0	Inf	-	-	-	-	-	-
4/1 (A508 South)	O		2	3	60.0	Geom	-	3.50	0.00	Y	Arm 3 Left	30.00
											Arm 9 Ahead	Inf
4/2 (A508 South)	O		2	3	10.0	Geom	-	3.50	0.00	N	Arm 9 Ahead	Inf
5/1	U		2	3	60.0	Inf	-	-	-	-	-	-
5/2	U		2	3	60.0	Inf	-	-	-	-	-	-
5/3	U		2	3	60.0	Inf	-	-	-	-	-	-
6/1 (Site Access)	U		2	3	60.0	Geom	-	3.50	0.00	Y	Arm 5 Left	30.00
6/2 (Site Access)	O		2	3	10.0	Inf	-	-	-	-	-	-
7/1	U	A	2	3	6.1	Geom	-	4.00	0.00	Y	Arm 2 Right	30.00
8/1	U		2	3	17.4	Inf	-	-	-	-	-	-
8/2	U		2	3	17.4	Inf	-	-	-	-	-	-
9/1	U		2	3	14.8	Inf	-	-	-	-	-	-
9/2	U		2	3	14.8	Inf	-	-	-	-	-	-

## Traffic Flow Groups

Flow Group	Start Time	End Time	Duration	Formula
1: '2031 with additional mez - AM'	08:00	09:00	01:00	
2: '2031 with additional mez - PM'	17:00	18:00	01:00	

**Scenario 1: '2031 with additional mez - AM'** (FG1: '2031 with additional mez - AM', Plan 1: 'Network Control Plan 1')

**Traffic Flows, Desired**

**Desired Flow :**

	Destination				
		A	B	C	Tot.
Origin	A	0	1575	935	2510
	B	1293	0	187	1480
	C	414	11	0	425
	Tot.	1707	1586	1122	4415

**Traffic Lane Flows**

Lane	Scenario 1: 2031 with additional mez - AM
<b>Junction: A508/Site Access</b>	
1/1	1050
1/2 (with short)	1460(In) 728(Out)
1/3 (short)	732
2/1	1061
2/2	525
3/1	390
3/2	732
4/1 (with short)	1480(In) 740(Out)
4/2 (short)	740
5/1	414
5/2	553
5/3	740
6/1 (with short)	425(In) 414(Out)
6/2 (short)	11
7/1	11
8/1	203
8/2	732
9/1	553
9/2	740

## Lane Saturation Flows

Junction: A508/Site Access								
Lane	Lane Width (m)	Gradient	Nearside Lane	Allowed Turns	Turning Radius (m)	Turning Prop.	Sat Flow (PCU/Hr)	Flared Sat Flow (PCU/Hr)
1/1 (A508 Notth)	3.65	0.00	Y	Arm 2 Ahead	22.00	100.0 %	1854	1854
1/2 (A508 Notth)	3.65	0.00	N	Arm 2 Ahead	25.00	72.1 %	2000	2000
				Arm 8 Right	25.00	27.9 %		
1/3 (A508 Notth)	3.65	0.00	N	Arm 8 Right	28.00	100.0 %	2012	2012
2/1	Infinite Saturation Flow						Inf	Inf
2/2	Infinite Saturation Flow						Inf	Inf
3/1	Infinite Saturation Flow						Inf	Inf
3/2	Infinite Saturation Flow						Inf	Inf
4/1 (A508 South)	3.50	0.00	Y	Arm 3 Left	30.00	25.3 %	1940	1940
				Arm 9 Ahead	Inf	74.7 %		
4/2 (A508 South)	3.50	0.00	N	Arm 9 Ahead	Inf	100.0 %	2105	2105
5/1	Infinite Saturation Flow						Inf	Inf
5/2	Infinite Saturation Flow						Inf	Inf
5/3	Infinite Saturation Flow						Inf	Inf
6/1 (Site Access)	3.50	0.00	Y	Arm 5 Left	30.00	100.0 %	1871	1871
6/2 (Site Access Lane 2)	Infinite Saturation Flow						Inf	Inf
7/1	4.00	0.00	Y	Arm 2 Right	30.00	100.0 %	1919	1919
8/1	Infinite Saturation Flow						Inf	Inf
8/2	Infinite Saturation Flow						Inf	Inf
9/1	Infinite Saturation Flow						Inf	Inf
9/2	Infinite Saturation Flow						Inf	Inf

Scenario 2: '2031 with additional mez - PM' (FG2: '2031 with additional mez - PM', Plan 1: 'Network Control Plan 1')

### Traffic Flows, Desired

#### Desired Flow :

	Destination				
	A	B	C	Tot.	
Origin	A	0	1651	499	2150
	B	1311	0	101	1412
	C	1130	81	0	1211
	Tot.	2441	1732	600	4773

## Traffic Lane Flows

Lane	Scenario 2: 2031 with additional mez - PM
<b>Junction: A508/Site Access</b>	
1/1	920
1/2 (with short)	1230(In) 731(Out)
1/3 (short)	499
2/1	1001
2/2	731
3/1	101
3/2	499
4/1 (with short)	1412(In) 709(Out)
4/2 (short)	703
5/1	1130
5/2	608
5/3	703
6/1 (with short)	1211(In) 1130(Out)
6/2 (short)	81
7/1	81
8/1	0
8/2	499
9/1	608
9/2	703

### Lane Saturation Flows

Junction: A508/Site Access								
Lane	Lane Width (m)	Gradient	Nearside Lane	Allowed Turns	Turning Radius (m)	Turning Prop.	Sat Flow (PCU/Hr)	Flared Sat Flow (PCU/Hr)
1/1 (A508 Notth)	3.65	0.00	Y	Arm 2 Ahead	22.00	100.0 %	1854	1854
1/2 (A508 Notth)	3.65	0.00	N	Arm 2 Ahead	25.00	100.0 %	2000	2000
				Arm 8 Right	25.00	0.0 %		
1/3 (A508 Notth)	3.65	0.00	N	Arm 8 Right	28.00	100.0 %	2012	2012
2/1	Infinite Saturation Flow						Inf	Inf
2/2	Infinite Saturation Flow						Inf	Inf
3/1	Infinite Saturation Flow						Inf	Inf
3/2	Infinite Saturation Flow						Inf	Inf
4/1 (A508 South)	3.50	0.00	Y	Arm 3 Left	30.00	14.2 %	1951	1951
				Arm 9 Ahead	Inf	85.8 %		
4/2 (A508 South)	3.50	0.00	N	Arm 9 Ahead	Inf	100.0 %	2105	2105
5/1	Infinite Saturation Flow						Inf	Inf
5/2	Infinite Saturation Flow						Inf	Inf
5/3	Infinite Saturation Flow						Inf	Inf
6/1 (Site Access)	3.50	0.00	Y	Arm 5 Left	30.00	100.0 %	1871	1871
6/2 (Site Access Lane 2)	Infinite Saturation Flow						Inf	Inf
7/1	4.00	0.00	Y	Arm 2 Right	30.00	100.0 %	1919	1919
8/1	Infinite Saturation Flow						Inf	Inf
8/2	Infinite Saturation Flow						Inf	Inf
9/1	Infinite Saturation Flow						Inf	Inf
9/2	Infinite Saturation Flow						Inf	Inf

Scenario 1: '2031 with additional mez - AM' (FG1: '2031 with additional mez - AM', Plan 1: 'Network Control Plan 1')

### Stage Sequence Diagram

Stage Stream: 1

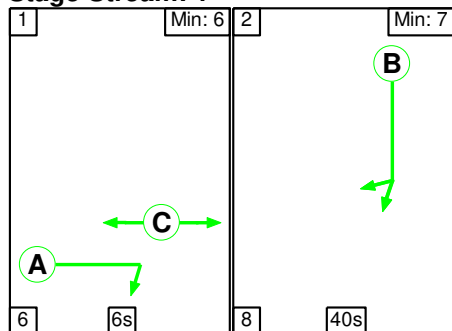

### Stage Timings

Stage Stream: 1

Stage	1	2
Duration	6	40
Change Point	0	12

### Signal Timings Diagram

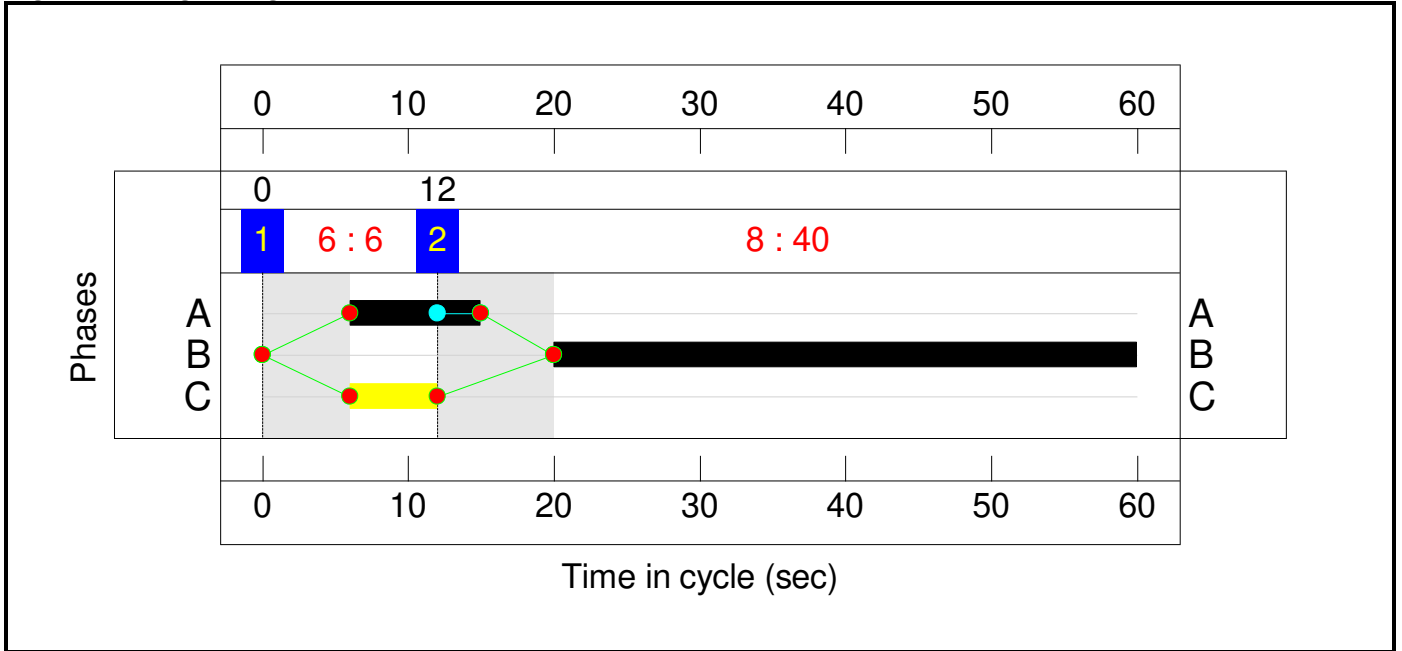

## Network Results

Item	Lane Description	Lane Type	Controller Stream	Position In Filtered Route	Full Phase	Arrow Phase	Num Greens	Total Green (s)	Arrow Green (s)	Demand Flow (pcu)	Sat Flow (pcu/Hr)	Capacity (pcu)	Deg Sat (%)
<b>Network</b>	-	-	<b>N/A</b>	-	-		-	-	-	-	-	-	<b>84.8%</b>
<b>A508/Site Access</b>	-	-	<b>N/A</b>	-	-		-	-	-	-	-	-	<b>84.8%</b>
1/1	A508 Notth Ahead	U	1	N/A	B		1	40	-	1050	1854	1267	82.9%
1/2+1/3	A508 Notth Ahead Right	U	1	N/A	B		1	40	-	1460	2000:2012	872+877	83.5 : 83.5%
4/1+4/2	A508 South Left Ahead	O	N/A	N/A	-		-	-	-	1480	1940:2105	872+872	84.8 : 84.8%
6/1+6/2	Site Access Left Ahead	U+O	N/A	N/A	-		-	-	-	425	1871: Inf	1868+50	22.2 : 22.2%
7/1	Right	U	1	N/A	A		1	9	-	11	1919	320	3.4%
Item	Arriving (pcu)	Leaving (pcu)	Turners In Gaps (pcu)	Turners When Unopposed (pcu)	Turners In Intergreen (pcu)	Uniform Delay (pcuHr)	Rand + Oversat Delay (pcuHr)	Storage Area Uniform Delay (pcuHr)	Total Delay (pcuHr)	Av. Delay Per PCU (s/pcu)	Max. Back of Uniform Queue (pcu)	Rand + Oversat Queue (pcu)	Mean Max Queue (pcu)
<b>Network</b>	-	-	<b>2971</b>	<b>0</b>	<b>0</b>	<b>4.3</b>	<b>7.8</b>	<b>0.0</b>	<b>12.1</b>	-	-	-	-
<b>A508/Site Access</b>	-	-	<b>2971</b>	<b>0</b>	<b>0</b>	<b>4.3</b>	<b>7.8</b>	<b>0.0</b>	<b>12.1</b>	-	-	-	-
1/1	1050	1050	-	-	-	2.0	2.4	-	4.4	15.1	12.5	2.4	14.9
1/2+1/3	1460	1460	-	-	-	1.9	2.5	-	4.4	10.9	5.9	2.5	8.4
4/1+4/2	1480	1480	2960	0	0	0.3	2.7	-	3.0	7.4	6.0	2.7	8.7
6/1+6/2	425	425	11	0	0	0.0	0.1	-	0.1	1.2	0.0	0.1	0.1
7/1	11	11	-	-	-	0.1	0.0	-	0.1	27.1	0.2	0.0	0.2
C1 Stream: 1 PRC for Signalled Lanes (%):					7.8	Total Delay for Signalled Lanes (pcuHr):			8.88	Cycle Time (s): 60			
PRC Over All Lanes (%):					6.1	Total Delay Over All Lanes(pcuHr):			12.06				

Scenario 2: '2031 with additional mez - PM' (FG2: '2031 with additional mez - PM', Plan 1: 'Network Control Plan 1')

### Stage Sequence Diagram

Stage Stream: 1

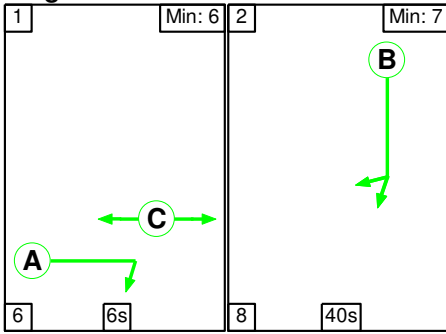

### Stage Timings

Stage Stream: 1

Stage	1	2
Duration	6	40
Change Point	0	12

### Signal Timings Diagram

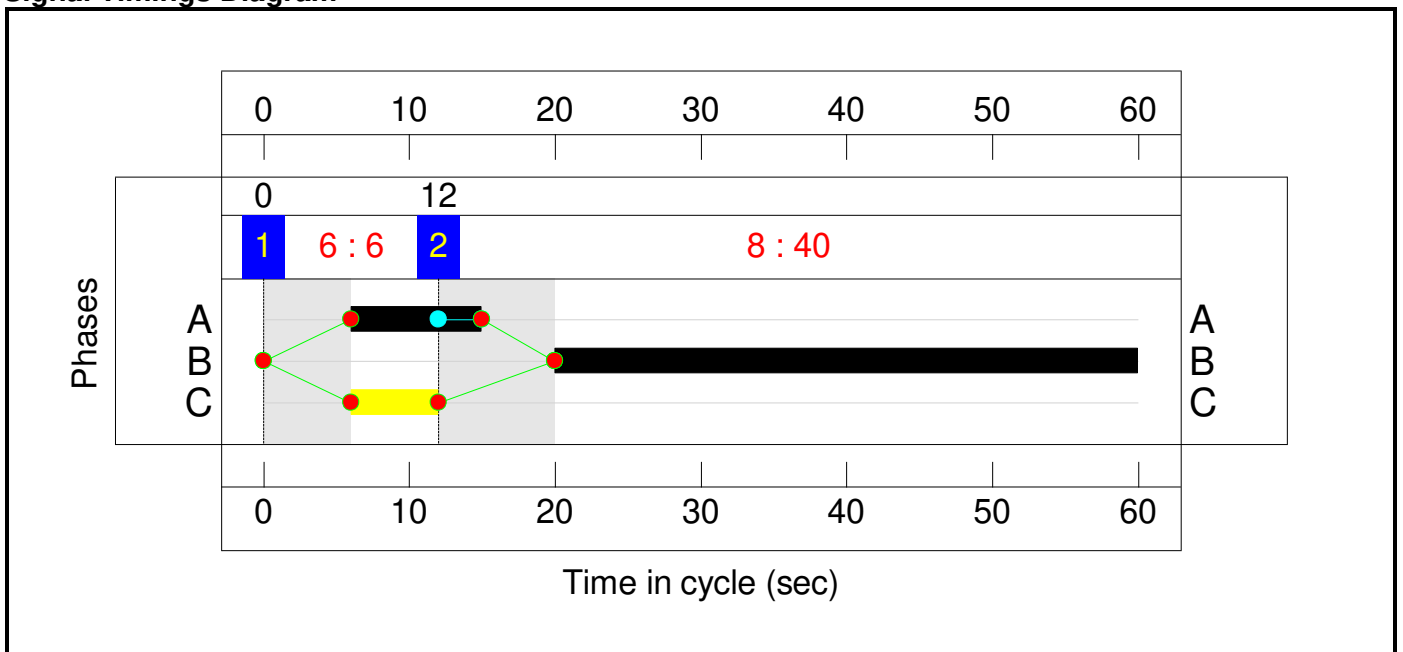

## Network Results

Item	Lane Description	Lane Type	Controller Stream	Position In Filtered Route	Full Phase	Arrow Phase	Num Greens	Total Green (s)	Arrow Green (s)	Demand Flow (pcu)	Sat Flow (pcu/Hr)	Capacity (pcu)	Deg Sat (%)	
<b>Network</b>	-	-	N/A	-	-		-	-	-	-	-	-	75.4%	
<b>A508/Site Access</b>	-	-	N/A	-	-		-	-	-	-	-	-	75.4%	
1/1	A508 Notth Ahead	U	1	N/A	B		1	40	-	920	1854	1267	72.6%	
1/2+1/3	A508 Notth Ahead Right	U	1	N/A	B		1	40	-	1230	2000:2012	970+662	75.4 : 75.4%	
4/1+4/2	A508 South Left Ahead	O	N/A	N/A	-		-	-	-	1412	1951:2105	981+981	72.3 : 71.6%	
6/1+6/2	Site Access Left Ahead	U+O	N/A	N/A	-		-	-	-	1211	1871: Inf	1864+134	60.6 : 60.6%	
7/1	Right	U	1	N/A	A		1	9	-	81	1919	320	25.3%	
Item	Arriving (pcu)	Leaving (pcu)	Turners In Gaps (pcu)	Turners When Unopposed (pcu)	Turners In Intergreen (pcu)	Uniform Delay (pcuHr)	Rand + Oversat Delay (pcuHr)	Storage Area Uniform Delay (pcuHr)	Total Delay (pcuHr)	Av. Delay Per PCU (s/pcu)	Max. Back of Uniform Queue (pcu)	Rand + Oversat Queue (pcu)	Mean Max Queue (pcu)	
<b>Network</b>	-	-	2905	0	0	3.5	5.1	0.0	8.6	-	-	-	-	
<b>A508/Site Access</b>	-	-	2905	0	0	3.5	5.1	0.0	8.6	-	-	-	-	
1/1	920	920	-	-	-	1.5	1.3	-	2.8	11.1	9.5	1.3	10.8	
1/2+1/3	1230	1230	-	-	-	1.5	1.5	-	3.0	8.9	5.9	1.5	7.4	
4/1+4/2	1412	1412	2824	0	0	0.0	1.3	-	1.3	3.3	0.8	1.3	2.1	
6/1+6/2	1211	1211	81	0	0	0.0	0.8	-	0.8	2.3	0.0	0.8	0.8	
7/1	81	81	-	-	-	0.5	0.2	-	0.7	29.3	1.2	0.2	1.3	
C1			Stream: 1 PRC for Signalled Lanes (%): 19.4			Total Delay for Signalled Lanes (pcuHr): 6.54			Cycle Time (s): 60					
			PRC Over All Lanes (%): 19.4			Total Delay Over All Lanes(pcuHr): 8.59								

## APPENDIX C

# M1 JUNCTION 15 LINSIG ASSESSMENT RESULTS

# Full Input Data And Results

## User and Project Details

Project:	Northampton Gateway
Title:	M1 Junction 15 impact with additional mezzanine
Location:	Northampton
Client:	Segro
Additional detail:	PM peak hour flows amended following feedback from NH. NB: adjustment made following removal of the Watering Lane Junction.
File name:	241101 M1 Junction 15 Mitigation - additional mez test.lsg3x
Author:	Mark Higgins
Company:	ADC Infrastructure
Address:	Nottingham

## Network Layout Diagram

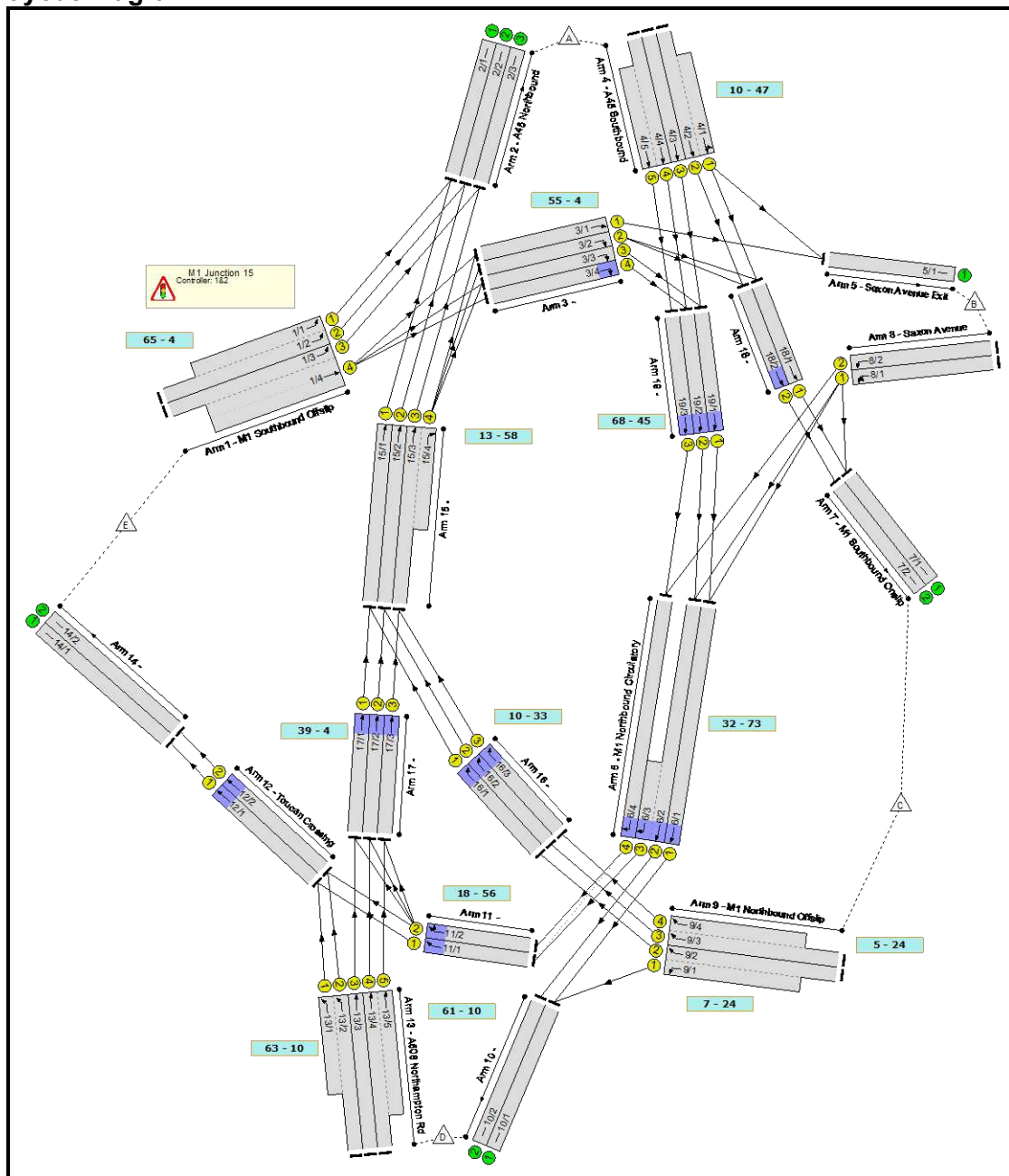

**C1 - Eastside Controller  
Phase Diagram**

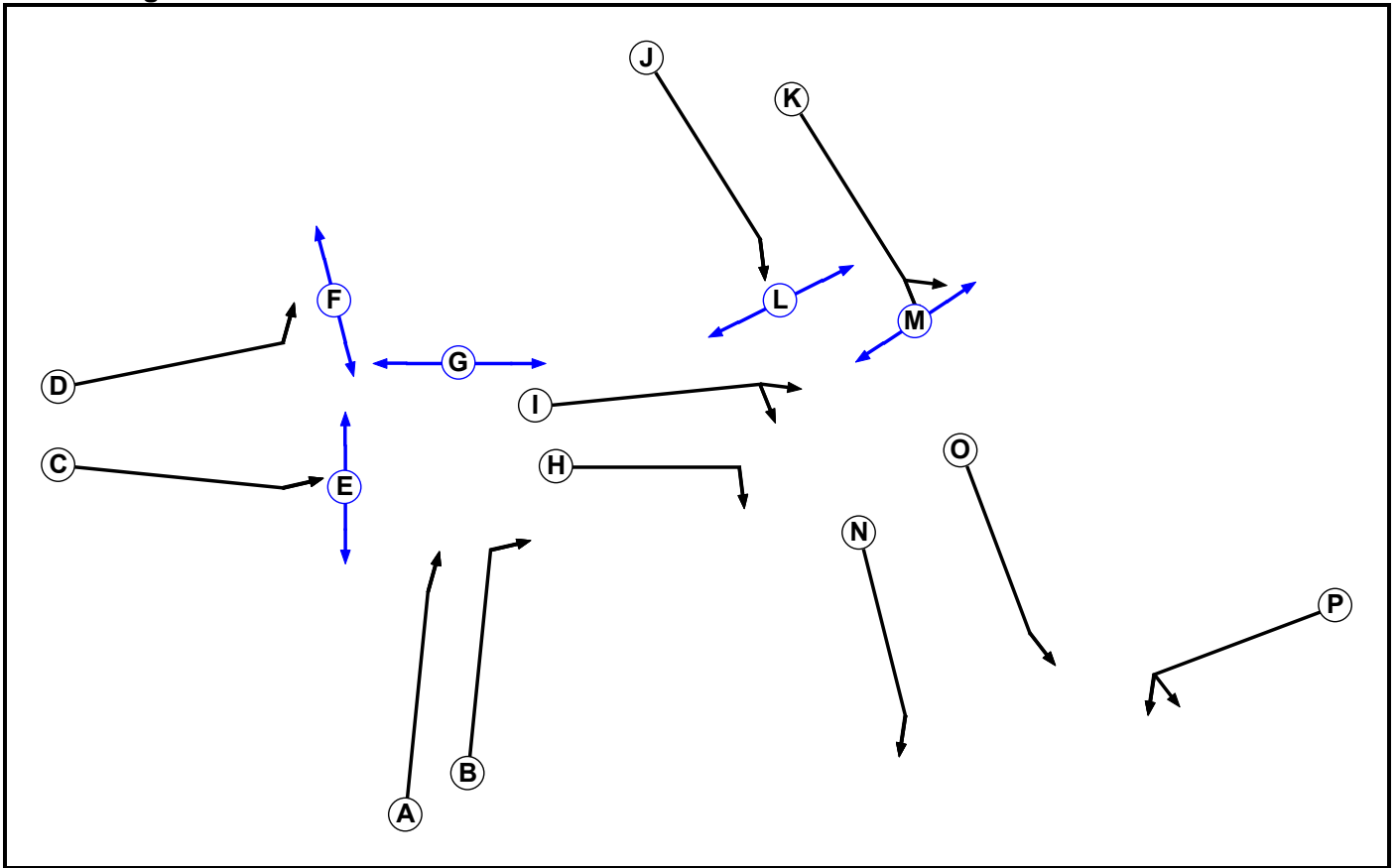

**Phase Input Data**

Phase Name	Phase Type	Stage Stream	Assoc. Phase	Street Min	Cont Min
A	Traffic	1		7	7
B	Traffic	1		7	7
C	Traffic	1		7	7
D	Traffic	1		7	7
E	Pedestrian	1		5	5
F	Pedestrian	1		5	5
G	Pedestrian	1		5	5
H	Traffic	2		7	7
I	Traffic	2		7	7
J	Traffic	2		7	7
K	Traffic	2		7	7
L	Pedestrian	2		5	5
M	Pedestrian	2		5	5
N	Traffic	3		7	7
O	Traffic	3		7	7
P	Traffic	3		7	7

## Phase Intergrens Matrix

		Starting Phase															
		A	B	C	D	E	F	G	H	I	J	K	L	M	N	O	P
Terminating Phase	A	-	-	5	7	-	-	8	-	-	-	-	-	-	-	-	-
	B	-	-	5	-	-	-	-	-	-	-	-	-	-	-	-	-
	C	9	9	-	-	7	-	-	-	-	-	-	-	-	-	-	-
	D	9	-	-	-	-	7	-	-	-	-	-	-	-	-	-	-
	E	-	-	5	-	-	-	-	-	-	-	-	-	-	-	-	-
	F	-	-	-	5	-	-	-	-	-	-	-	-	-	-	-	-
	G	5	-	-	-	-	-	-	-	-	-	-	-	-	-	-	-
	H	-	-	-	-	-	-	-	-	-	5	6	-	-	-	-	-
	I	-	-	-	-	-	-	-	-	-	5	6	-	-	-	-	-
	J	-	-	-	-	-	-	-	9	8	-	-	7	-	-	-	-
	K	-	-	-	-	-	-	-	-	7	-	-	-	7	-	-	-
	L	-	-	-	-	-	-	-	-	-	5	-	-	-	-	-	-
	M	-	-	-	-	-	-	-	-	-	-	5	-	-	-	-	-
	N	-	-	-	-	-	-	-	-	-	-	-	-	-	-	-	5
O	-	-	-	-	-	-	-	-	-	-	-	-	-	-	-	6	
P	-	-	-	-	-	-	-	-	-	-	-	-	-	-	10	7	

## Phases in Stage

Stream	Stage No.	Phases in Stage
1	1	A B E F
1	2	C D G
2	1	H I L M
2	2	J K
3	1	N O
3	2	P

## Stage Diagram

### Stage Stream: 1

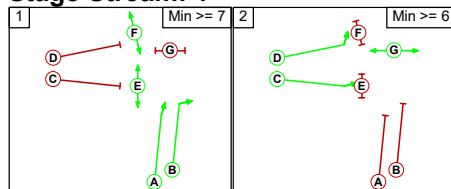

### Stage Stream: 2

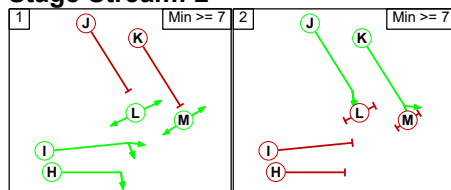

### Stage Stream: 3

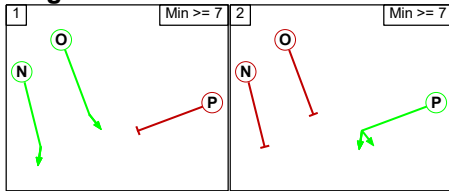

### Phase Delays

#### Stage Stream: 1

Term. Stage	Start Stage	Phase	Type	Value	Cont value
There are no Phase Delays defined					

#### Stage Stream: 2

Term. Stage	Start Stage	Phase	Type	Value	Cont value
There are no Phase Delays defined					

#### Stage Stream: 3

Term. Stage	Start Stage	Phase	Type	Value	Cont value
There are no Phase Delays defined					

### Prohibited Stage Change

#### Stage Stream: 1

From Stage	To Stage	
	1	2
1	8	
2	9	

#### Stage Stream: 2

From Stage	To Stage	
	1	2
1	6	
2	9	

#### Stage Stream: 3

From Stage	To Stage	
	1	2
1	6	
2	10	

**C2 - Westside Controller  
Phase Diagram**

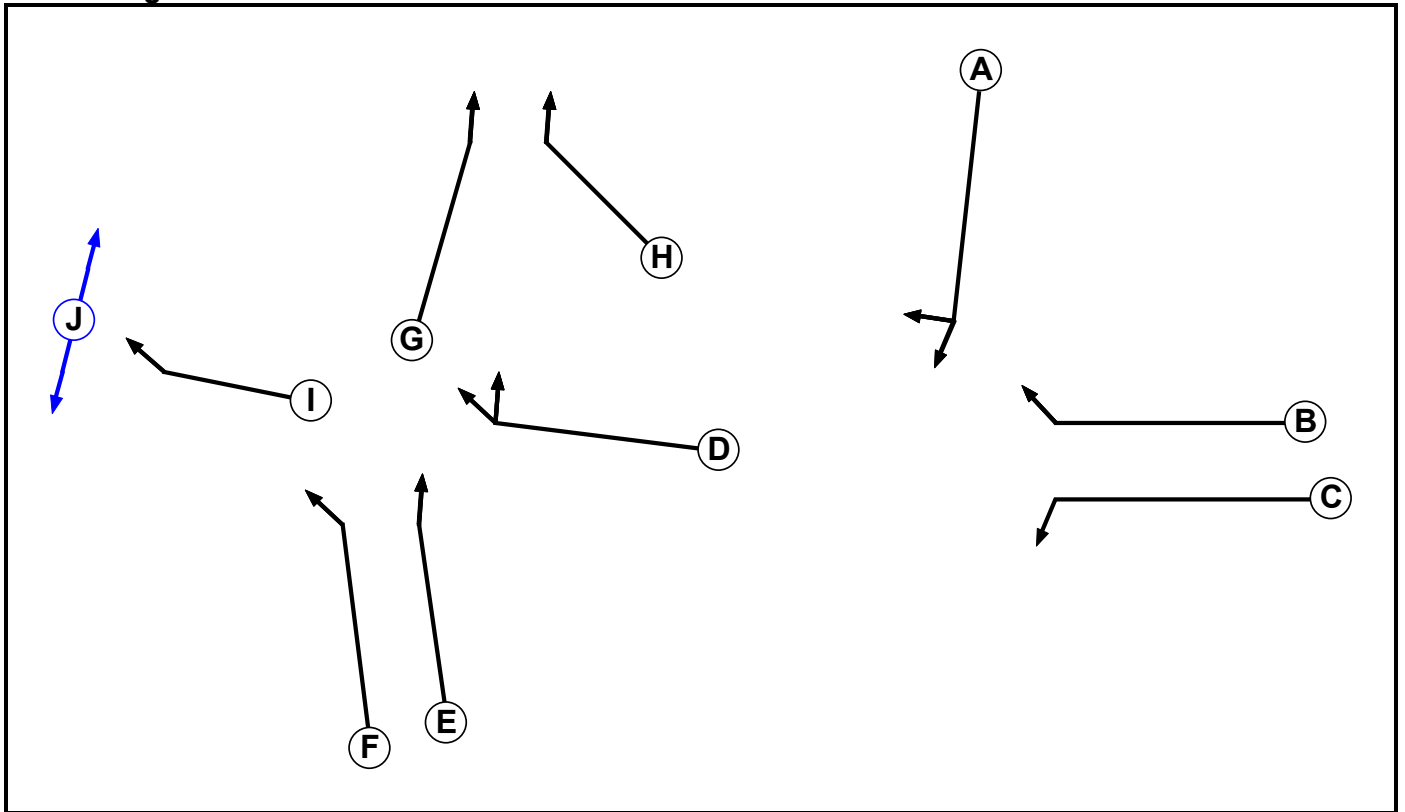

**Phase Input Data**

Phase Name	Phase Type	Stage Stream	Assoc. Phase	Street Min	Cont Min
A	Traffic	1		7	7
B	Traffic	1		7	7
C	Traffic	1		7	7
D	Traffic	2		7	7
E	Traffic	2		7	7
F	Traffic	2		7	7
G	Traffic	3		7	7
H	Traffic	3		7	7
I	Traffic	4		7	7
J	Pedestrian	4		5	5

### Phase Intergreens Matrix

		Starting Phase									
		A	B	C	D	E	F	G	H	I	J
Terminating Phase	A	8	10	-	-	-	-	-	-	-	-
	B	8	-	-	-	-	-	-	-	-	-
	C	7	-	-	-	-	-	-	-	-	-
	D	-	-	-	5	7	-	-	-	-	-
	E	-	-	-	8	-	-	-	-	-	-
	F	-	-	-	7	-	-	-	-	-	-
	G	-	-	-	-	-	-	6	-	-	-
	H	-	-	-	-	-	-	6	-	-	-
	I	-	-	-	-	-	-	-	-	7	-
	J	-	-	-	-	-	-	-	-	5	-

### Phases in Stage

Stream	Stage No.	Phases in Stage
1	1	A
1	2	B C
2	1	D
2	2	E F
3	1	G
3	2	H
4	1	I
4	2	J

### Stage Diagram

#### Stage Stream: 1

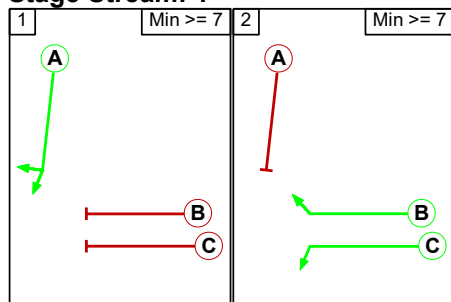

#### Stage Stream: 2

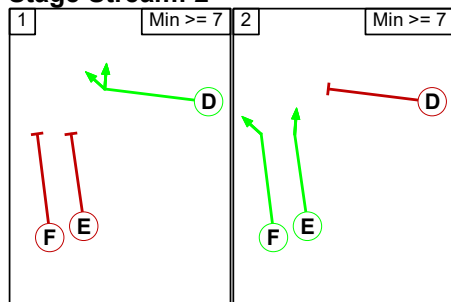

### Stage Stream: 3

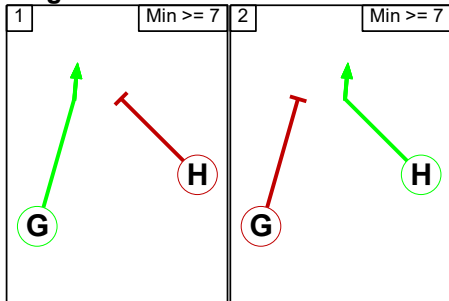

### Stage Stream: 4

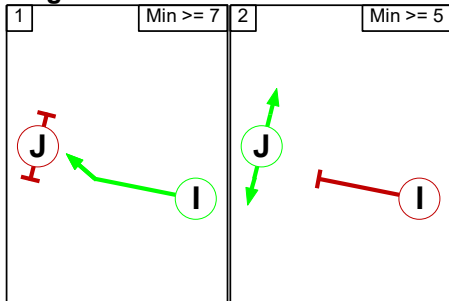

### Phase Delays

#### Stage Stream: 1

Term. Stage	Start Stage	Phase	Type	Value	Cont value
There are no Phase Delays defined					

#### Stage Stream: 2

Term. Stage	Start Stage	Phase	Type	Value	Cont value
There are no Phase Delays defined					

#### Stage Stream: 3

Term. Stage	Start Stage	Phase	Type	Value	Cont value
There are no Phase Delays defined					

#### Stage Stream: 4

Term. Stage	Start Stage	Phase	Type	Value	Cont value
There are no Phase Delays defined					

### Prohibited Stage Change

#### Stage Stream: 1

		To Stage	
		1	2
From Stage	1		10
	2	8	

#### Stage Stream: 2

		To Stage	
		1	2
From Stage	1		7
	2	8	

**Stage Stream: 3**

	To Stage	
From Stage		1 2
	1	6
	2	6

**Stage Stream: 4**

	To Stage	
From Stage		1 2
	1	7
	2	5

## Lane Input Data

Junction: M1 Junction 15												
Lane	Lane Type	Phases	Start Disp.	End Disp.	Physical Length (PCU)	Sat Flow Type	Def User Saturation Flow (PCU/Hr)	Lane Width (m)	Gradient	Nearside Lane	Turns	Turning Radius (m)
1/1 (M1 Southbound Offslip)	U	D	2	3	18.0	Geom	-	3.65	0.00	Y	Arm 2 Left	Inf
1/2 (M1 Southbound Offslip)	U	D	2	3	60.0	Geom	-	3.65	0.00	N	Arm 2 Left	Inf
1/3 (M1 Southbound Offslip)	U	D	2	3	60.0	Geom	-	3.65	0.00	N	Arm 2 Left	Inf
1/4 (M1 Southbound Offslip)	U	C	2	3	18.0	User	4000	-	-	-	-	-
2/1 (A45 Northbound)	U		2	3	4.3	Inf	-	-	-	-	-	-
2/2 (A45 Northbound)	U		2	3	4.3	Inf	-	-	-	-	-	-
2/3 (A45 Northbound)	U		2	3	4.3	Inf	-	-	-	-	-	-
3/1	U	I	2	3	11.3	User	1900	-	-	-	-	-
3/2	U	I	2	3	11.3	User	1900	-	-	-	-	-
3/3	U	H	2	3	11.3	User	1900	-	-	-	-	-
3/4	U	H	2	3	11.3	User	1900	-	-	-	-	-
4/1 (A45 Southbound)	U	K	2	3	33.0	Geom	-	3.65	0.00	Y	Arm 5 Left	Inf
											Arm 18 Ahead	Inf
4/2 (A45 Southbound)	U	K	2	3	67.8	Geom	-	3.65	0.00	N	Arm 18 Ahead	Inf
4/3 (A45 Southbound)	U	J	2	3	67.8	Geom	-	3.65	0.00	N	Arm 19 Ahead	Inf
4/4 (A45 Southbound)	U	J	2	3	67.8	Geom	-	3.65	0.00	N	Arm 19 Ahead	Inf
4/5 (A45 Southbound)	U	J	2	3	33.0	Geom	-	3.65	0.00	N	Arm 19 Ahead	Inf
5/1 (Saxon Avenue Exit)	U		2	3	4.3	Inf	-	-	-	-	-	-

6/1 (M1 Northbound Circulatory)	U	A	2	3	33.9	User	2120	-	-	-	-	-
6/2 (M1 Northbound Circulatory)	U	A	2	3	33.9	User	2120	-	-	-	-	-
6/3 (M1 Northbound Circulatory)	U	A	2	3	8.0	User	2120	-	-	-	-	-
6/4 (M1 Northbound Circulatory)	U	A	2	3	33.9	User	2120	-	-	-	-	-
7/1 (M1 Southbound Onslip)	U		2	3	4.3	Inf	-	-	-	-	-	-
7/2 (M1 Southbound Onslip)	U		2	3	4.3	Inf	-	-	-	-	-	-
8/1 (Saxon Avenue)	U	P	2	3	60.0	Geom	-	3.50	0.00	Y	Arm 6 Left	Inf
											Arm 7 Left	30.00
8/2 (Saxon Avenue)	U	P	2	3	60.0	Geom	-	3.50	0.00	N	Arm 6 Left	Inf
9/1 (M1 Northbound Offslip)	U	C	2	3	15.7	Geom	-	3.65	0.00	Y	Arm 10 Left	Inf
9/2 (M1 Northbound Offslip)	U	B	2	3	60.0	Geom	-	3.65	0.00	N	Arm 16 Ahead	Inf
9/3 (M1 Northbound Offslip)	U	B	2	3	60.0	Geom	-	3.65	0.00	N	Arm 16 Ahead	Inf
9/4 (M1 Northbound Offslip)	U	B	2	3	31.3	Geom	-	3.65	0.00	N	Arm 16 Ahead	Inf
10/1	U		2	3	4.3	Inf	-	-	-	-	-	-
10/2	U		2	3	4.3	Inf	-	-	-	-	-	-
11/1	U	D	2	3	20.0	User	1900	-	-	-	-	-
11/2	U	D	2	3	20.0	User	1900	-	-	-	-	-
12/1 (Toucan Crossing)	U	I	2	3	7.0	Geom	-	3.80	0.00	Y	Arm 14 Ahead	Inf
12/2 (Toucan Crossing)	U	I	2	3	7.0	Geom	-	3.80	0.00	Y	Arm 14 Ahead	Inf

13/1 (A508 Northampton Rd)	U	F	2	3	10.0	Geom	-	3.65	0.00	Y	Arm 12 Ahead	Inf
13/2 (A508 Northampton Rd)	U	F	2	3	60.0	Geom	-	3.65	0.00	Y	Arm 12 Ahead	Inf
13/3 (A508 Northampton Rd)	U	E	2	3	60.0	Geom	-	3.65	0.00	N	Arm 17 Ahead	Inf
13/4 (A508 Northampton Rd)	U	E	2	3	60.0	Geom	-	3.65	0.00	N	Arm 17 Ahead	Inf
13/5 (A508 Northampton Rd)	U	E	2	3	20.0	Geom	-	3.65	0.00	N	Arm 17 Ahead	Inf
14/1	U		2	3	60.0	Inf	-	-	-	-	-	-
14/2	U		2	3	60.0	Inf	-	-	-	-	-	-
15/1	U	A	2	3	34.8	User	2000	-	-	-	-	-
15/2	U	A	2	3	34.8	User	2000	-	-	-	-	-
15/3	U	A	2	3	34.8	User	2000	-	-	-	-	-
15/4	U	B	2	3	10.4	User	2000	-	-	-	-	-
16/1	U	H	2	3	10.4	User	2000	-	-	-	-	-
16/2	U	H	2	3	10.4	User	2000	-	-	-	-	-
16/3	U	H	2	3	10.4	User	2000	-	-	-	-	-
17/1	U	G	2	3	14.8	User	2000	-	-	-	-	-
17/2	U	G	2	3	14.8	User	2000	-	-	-	-	-
17/3	U	G	2	3	14.8	User	2000	-	-	-	-	-
18/1	U	O	2	3	11.3	User	2000	-	-	-	-	-
18/2	U	O	2	3	11.3	User	2000	-	-	-	-	-
19/1	U	N	2	3	13.0	User	2000	-	-	-	-	-
19/2	U	N	2	3	13.0	User	2120	-	-	-	-	-
19/3	U	N	2	3	13.0	User	2120	-	-	-	-	-

### Traffic Flow Groups

Flow Group	Start Time	End Time	Duration	Formula
1: '2031 background - AM'	08:00	09:00	01:00	
2: '2031 background - PM'	17:00	18:00	01:00	
3: '2031 with additional mez - AM'	08:00	09:00	01:00	
4: '2031 with additional mez - PM'	17:00	18:00	01:00	

**Scenario 1: '2031 Background - AM'** (FG1: '2031 background - AM', Plan 1: 'Network Control Plan 1')  
**Traffic Flows, Desired**  
**Desired Flow :**

		Destination					
		A	B	C	D	E	Tot.
Origin	A	35	32	959	1105	1714	3845
	B	41	0	20	17	67	145
	C	1705	51	0	330	0	2086
	D	715	25	198	31	649	1618
	E	1230	116	0	784	3	2133
	Tot.	3726	224	1177	2267	2433	9827

## Traffic Lane Flows

Lane	Scenario 1: 2031 Background - AM
<b>Junction: M1 Junction 15</b>	
1/1 (short)	376
1/2 (with short)	779(In) 403(Out)
1/3 (with short)	1354(In) 451(Out)
1/4 (short)	903
2/1	1299
2/2	1318
2/3	1109
3/1	192
3/2	198
3/3	319
3/4	499
4/1 (short)	493
4/2 (with short)	991(In) 498(Out)
4/3	944
4/4 (with short)	1910(In) 956(Out)
4/5 (short)	954
5/1	224
6/1	1263
6/2 (with short)	1503(In) 674(Out)
6/3 (short)	829
6/4	1031
7/1	580
7/2	597
8/1	68
8/2	77
9/1 (short)	330
9/2 (with short)	914(In) 584(Out)
9/3 (with short)	1172(In) 586(Out)
9/4 (short)	586
10/1	1593
10/2	674
11/1	900

11/2	960
12/1	1224
12/2	1209
13/1 (short)	324
13/2 (with short)	649(In) 325(Out)
13/3	304
13/4 (with short)	665(In) 329(Out)
13/5 (short)	336
14/1	1224
14/2	1209
15/1	923
15/2	915
15/3 (with short)	963(In) 658(Out)
15/4 (short)	305
16/1	584
16/2	586
16/3	586
17/1	339
17/2	329
17/3	377
18/1	560
18/2	597
19/1	1263
19/2	1455
19/3	954

## Lane Saturation Flows

Junction: M1 Junction 15								
Lane	Lane Width (m)	Gradient	Nearside Lane	Allowed Turns	Turning Radius (m)	Turning Prop.	Sat Flow (PCU/Hr)	Flared Sat Flow (PCU/Hr)
1/1 (M1 Southbound Offslip)	3.65	0.00	Y	Arm 2 Left	Inf	100.0 %	1980	1980
1/2 (M1 Southbound Offslip)	3.65	0.00	N	Arm 2 Left	Inf	100.0 %	2120	2120
1/3 (M1 Southbound Offslip)	3.65	0.00	N	Arm 2 Left	Inf	100.0 %	2120	2120
1/4 (M1 Southbound Offslip Lane 4)	This lane uses a directly entered Saturation Flow						4000	4000
2/1 (A45 Northbound Lane 1)	Infinite Saturation Flow						Inf	Inf
2/2 (A45 Northbound Lane 2)	Infinite Saturation Flow						Inf	Inf
2/3 (A45 Northbound Lane 3)	Infinite Saturation Flow						Inf	Inf
3/1	This lane uses a directly entered Saturation Flow						1900	1900
3/2	This lane uses a directly entered Saturation Flow						1900	1900
3/3	This lane uses a directly entered Saturation Flow						1900	1900
3/4	This lane uses a directly entered Saturation Flow						1900	1900
4/1 (A45 Southbound)	3.65	0.00	Y	Arm 5 Left	Inf	6.5 %	1980	1980
4/2 (A45 Southbound)				Arm 18 Ahead	Inf	93.5 %		
4/3 (A45 Southbound)	3.65	0.00	N	Arm 18 Ahead	Inf	100.0 %	2120	2120
4/4 (A45 Southbound)	3.65	0.00	N	Arm 19 Ahead	Inf	100.0 %	2120	2120
4/5 (A45 Southbound)	3.65	0.00	N	Arm 19 Ahead	Inf	100.0 %	2120	2120
5/1 (Saxon Avenue Exit Lane 1)	Infinite Saturation Flow						Inf	Inf
6/1 (M1 Northbound Circulatory Lane 1)	This lane uses a directly entered Saturation Flow						2120	2120
6/2 (M1 Northbound Circulatory Lane 2)	This lane uses a directly entered Saturation Flow						2120	2120
6/3 (M1 Northbound Circulatory Lane 3)	This lane uses a directly entered Saturation Flow						2120	2120
6/4 (M1 Northbound Circulatory Lane 4)	This lane uses a directly entered Saturation Flow						2120	2120
7/1 (M1 Southbound Onslip Lane 1)	Infinite Saturation Flow						Inf	Inf
7/2 (M1 Southbound Onslip Lane 2)	Infinite Saturation Flow						Inf	Inf

8/1 (Saxon Avenue)	3.50	0.00	Y	Arm 6 Left	Inf	70.6 %	1937	1937
				Arm 7 Left	30.00	29.4 %		
8/2 (Saxon Avenue)	3.50	0.00	N	Arm 6 Left	Inf	100.0 %	2105	2105
9/1 (M1 Northbound Offslip)	3.65	0.00	Y	Arm 10 Left	Inf	100.0 %	1980	1980
9/2 (M1 Northbound Offslip)	3.65	0.00	N	Arm 16 Ahead	Inf	100.0 %	2120	2120
9/3 (M1 Northbound Offslip)	3.65	0.00	N	Arm 16 Ahead	Inf	100.0 %	2120	2120
9/4 (M1 Northbound Offslip)	3.65	0.00	N	Arm 16 Ahead	Inf	100.0 %	2120	2120
10/1	Infinite Saturation Flow						Inf	Inf
10/2	Infinite Saturation Flow						Inf	Inf
11/1	This lane uses a directly entered Saturation Flow						1900	1900
11/2	This lane uses a directly entered Saturation Flow						1900	1900
12/1 (Toucan Crossing)	3.80	0.00	Y	Arm 14 Ahead	Inf	100.0 %	1995	1995
12/2 (Toucan Crossing)	3.80	0.00	Y	Arm 14 Ahead	Inf	100.0 %	1995	1995
13/1 (A508 Northampton Rd)	3.65	0.00	Y	Arm 12 Ahead	Inf	100.0 %	1980	1980
13/2 (A508 Northampton Rd)	3.65	0.00	Y	Arm 12 Ahead	Inf	100.0 %	1980	1980
13/3 (A508 Northampton Rd)	3.65	0.00	N	Arm 17 Ahead	Inf	100.0 %	2120	2120
13/4 (A508 Northampton Rd)	3.65	0.00	N	Arm 17 Ahead	Inf	100.0 %	2120	2120
13/5 (A508 Northampton Rd)	3.65	0.00	N	Arm 17 Ahead	Inf	100.0 %	2120	2120
14/1	Infinite Saturation Flow						Inf	Inf
14/2	Infinite Saturation Flow						Inf	Inf
15/1	This lane uses a directly entered Saturation Flow						2000	2000
15/2	This lane uses a directly entered Saturation Flow						2000	2000
15/3	This lane uses a directly entered Saturation Flow						2000	2000
15/4	This lane uses a directly entered Saturation Flow						2000	2000
16/1	This lane uses a directly entered Saturation Flow						2000	2000
16/2	This lane uses a directly entered Saturation Flow						2000	2000
16/3	This lane uses a directly entered Saturation Flow						2000	2000
17/1	This lane uses a directly entered Saturation Flow						2000	2000
17/2	This lane uses a directly entered Saturation Flow						2000	2000
17/3	This lane uses a directly entered Saturation Flow						2000	2000
18/1	This lane uses a directly entered Saturation Flow						2000	2000
18/2	This lane uses a directly entered Saturation Flow						2000	2000
19/1	This lane uses a directly entered Saturation Flow						2000	2000
19/2	This lane uses a directly entered Saturation Flow						2120	2120
19/3	This lane uses a directly entered Saturation Flow						2120	2120

**Scenario 2: '2031 With additional mez - AM'** (FG3: '2031 with additional mez - AM', Plan 1: 'Network Control Plan 1')

**Traffic Flows, Desired**

**Desired Flow :**

	Destination						
	A	B	C	D	E	Tot.	
Origin	A	35	32	959	1142	1714	3882
	B	41	0	20	17	67	145
	C	1705	51	0	357	0	2113
	D	730	25	208	31	658	1652
	E	1230	116	0	807	3	2156
	Tot.	3741	224	1187	2354	2442	9948

## Traffic Lane Flows

Lane	Scenario 2: 2031 With additional mez - AM
<b>Junction: M1 Junction 15</b>	
1/1 (short)	379
1/2 (with short)	785(In) 406(Out)
1/3 (with short)	1371(In) 445(Out)
1/4 (short)	926
2/1	1309
2/2	1330
2/3	1102
3/1	192
3/2	208
3/3	319
3/4	522
4/1 (short)	493
4/2 (with short)	991(In) 498(Out)
4/3	956
4/4 (with short)	1935(In) 968(Out)
4/5 (short)	967
5/1	224
6/1	1275
6/2 (with short)	1533(In) 722(Out)
6/3 (short)	811
6/4	1049
7/1	585
7/2	602
8/1	63
8/2	82
9/1 (short)	357
9/2 (with short)	941(In) 584(Out)
9/3 (with short)	1172(In) 586(Out)
9/4 (short)	586
10/1	1632
10/2	722
11/1	913

11/2	947
12/1	1242
12/2	1200
13/1 (short)	329
13/2 (with short)	658(In) 329(Out)
13/3	311
13/4 (with short)	683(In) 338(Out)
13/5 (short)	345
14/1	1242
14/2	1200
15/1	930
15/2	924
15/3 (with short)	972(In) 657(Out)
15/4 (short)	315
16/1	584
16/2	586
16/3	586
17/1	346
17/2	338
17/3	386
18/1	565
18/2	602
19/1	1275
19/2	1490
19/3	967

## Lane Saturation Flows

Junction: M1 Junction 15								
Lane	Lane Width (m)	Gradient	Nearside Lane	Allowed Turns	Turning Radius (m)	Turning Prop.	Sat Flow (PCU/Hr)	Flared Sat Flow (PCU/Hr)
1/1 (M1 Southbound Offslip)	3.65	0.00	Y	Arm 2 Left	Inf	100.0 %	1980	1980
1/2 (M1 Southbound Offslip)	3.65	0.00	N	Arm 2 Left	Inf	100.0 %	2120	2120
1/3 (M1 Southbound Offslip)	3.65	0.00	N	Arm 2 Left	Inf	100.0 %	2120	2120
1/4 (M1 Southbound Offslip Lane 4)	This lane uses a directly entered Saturation Flow						4000	4000
2/1 (A45 Northbound Lane 1)	Infinite Saturation Flow						Inf	Inf
2/2 (A45 Northbound Lane 2)	Infinite Saturation Flow						Inf	Inf
2/3 (A45 Northbound Lane 3)	Infinite Saturation Flow						Inf	Inf
3/1	This lane uses a directly entered Saturation Flow						1900	1900
3/2	This lane uses a directly entered Saturation Flow						1900	1900
3/3	This lane uses a directly entered Saturation Flow						1900	1900
3/4	This lane uses a directly entered Saturation Flow						1900	1900
4/1 (A45 Southbound)	3.65	0.00	Y	Arm 5 Left	Inf	6.5 %	1980	1980
				Arm 18 Ahead	Inf	93.5 %		
4/2 (A45 Southbound)	3.65	0.00	N	Arm 18 Ahead	Inf	100.0 %	2120	2120
4/3 (A45 Southbound)	3.65	0.00	N	Arm 19 Ahead	Inf	100.0 %	2120	2120
4/4 (A45 Southbound)	3.65	0.00	N	Arm 19 Ahead	Inf	100.0 %	2120	2120
4/5 (A45 Southbound)	3.65	0.00	N	Arm 19 Ahead	Inf	100.0 %	2120	2120
5/1 (Saxon Avenue Exit Lane 1)	Infinite Saturation Flow						Inf	Inf
6/1 (M1 Northbound Circulatory Lane 1)	This lane uses a directly entered Saturation Flow						2120	2120
6/2 (M1 Northbound Circulatory Lane 2)	This lane uses a directly entered Saturation Flow						2120	2120
6/3 (M1 Northbound Circulatory Lane 3)	This lane uses a directly entered Saturation Flow						2120	2120
6/4 (M1 Northbound Circulatory Lane 4)	This lane uses a directly entered Saturation Flow						2120	2120
7/1 (M1 Southbound Onslip Lane 1)	Infinite Saturation Flow						Inf	Inf
7/2 (M1 Southbound Onslip Lane 2)	Infinite Saturation Flow						Inf	Inf

8/1 (Saxon Avenue)	3.50	0.00	Y	Arm 6 Left	Inf	68.3 %	1934	1934
				Arm 7 Left	30.00	31.7 %		
8/2 (Saxon Avenue)	3.50	0.00	N	Arm 6 Left	Inf	100.0 %	2105	2105
9/1 (M1 Northbound Offslip)	3.65	0.00	Y	Arm 10 Left	Inf	100.0 %	1980	1980
9/2 (M1 Northbound Offslip)	3.65	0.00	N	Arm 16 Ahead	Inf	100.0 %	2120	2120
9/3 (M1 Northbound Offslip)	3.65	0.00	N	Arm 16 Ahead	Inf	100.0 %	2120	2120
9/4 (M1 Northbound Offslip)	3.65	0.00	N	Arm 16 Ahead	Inf	100.0 %	2120	2120
10/1	Infinite Saturation Flow						Inf	Inf
10/2	Infinite Saturation Flow						Inf	Inf
11/1	This lane uses a directly entered Saturation Flow						1900	1900
11/2	This lane uses a directly entered Saturation Flow						1900	1900
12/1 (Toucan Crossing)	3.80	0.00	Y	Arm 14 Ahead	Inf	100.0 %	1995	1995
12/2 (Toucan Crossing)	3.80	0.00	Y	Arm 14 Ahead	Inf	100.0 %	1995	1995
13/1 (A508 Northampton Rd)	3.65	0.00	Y	Arm 12 Ahead	Inf	100.0 %	1980	1980
13/2 (A508 Northampton Rd)	3.65	0.00	Y	Arm 12 Ahead	Inf	100.0 %	1980	1980
13/3 (A508 Northampton Rd)	3.65	0.00	N	Arm 17 Ahead	Inf	100.0 %	2120	2120
13/4 (A508 Northampton Rd)	3.65	0.00	N	Arm 17 Ahead	Inf	100.0 %	2120	2120
13/5 (A508 Northampton Rd)	3.65	0.00	N	Arm 17 Ahead	Inf	100.0 %	2120	2120
14/1	Infinite Saturation Flow						Inf	Inf
14/2	Infinite Saturation Flow						Inf	Inf
15/1	This lane uses a directly entered Saturation Flow						2000	2000
15/2	This lane uses a directly entered Saturation Flow						2000	2000
15/3	This lane uses a directly entered Saturation Flow						2000	2000
15/4	This lane uses a directly entered Saturation Flow						2000	2000
16/1	This lane uses a directly entered Saturation Flow						2000	2000
16/2	This lane uses a directly entered Saturation Flow						2000	2000
16/3	This lane uses a directly entered Saturation Flow						2000	2000
17/1	This lane uses a directly entered Saturation Flow						2000	2000
17/2	This lane uses a directly entered Saturation Flow						2000	2000
17/3	This lane uses a directly entered Saturation Flow						2000	2000
18/1	This lane uses a directly entered Saturation Flow						2000	2000
18/2	This lane uses a directly entered Saturation Flow						2000	2000
19/1	This lane uses a directly entered Saturation Flow						2000	2000
19/2	This lane uses a directly entered Saturation Flow						2120	2120
19/3	This lane uses a directly entered Saturation Flow						2120	2120

**Scenario 3: '2031 Background - PM '** (FG2: '2031 background - PM', Plan 1: 'Network Control Plan 1')

**Traffic Flows, Desired**

**Desired Flow :**

	Destination						
	A	B	C	D	E	Tot.	
Origin	A	117	88	985	1199	1279	3668
	B	30	0	121	18	100	269
	C	1503	25	0	205	0	1733
	D	1440	13	199	50	709	2411
	E	1007	99	0	563	0	1669
	Tot.	4097	225	1305	2035	2088	9750

## Traffic Lane Flows

Lane	Scenario 3: 2031 Background - PM
<b>Junction: M1 Junction 15</b>	
1/1 (short)	292
1/2 (with short)	604(In) 312(Out)
1/3 (with short)	1065(In) 403(Out)
1/4 (short)	662
2/1	1431
2/2	1374
2/3	1292
3/1	137
3/2	199
3/3	261
3/4	352
4/1 (short)	534
4/2 (with short)	1073(In) 539(Out)
4/3	866
4/4 (with short)	1729(In) 682(Out)
4/5 (short)	1047
5/1	225
6/1	1127
6/2 (with short)	1053(In) 703(Out)
6/3 (short)	350
6/4	1176
7/1	676
7/2	629
8/1	140
8/2	129
9/1 (short)	205
9/2 (with short)	698(In) 493(Out)
9/3 (with short)	1035(In) 475(Out)
9/4 (short)	560
10/1	1332
10/2	703
11/1	656

11/2	870
12/1	1010
12/2	1078
13/1 (short)	354
13/2 (with short)	709(In) 355(Out)
13/3	516
13/4 (with short)	1186(In) 571(Out)
13/5 (short)	615
14/1	1010
14/2	1078
15/1	1139
15/2	1062
15/3 (with short)	1176(In) 889(Out)
15/4 (short)	287
16/1	493
16/2	475
16/3	560
17/1	646
17/2	587
17/3	616
18/1	555
18/2	629
19/1	1127
19/2	1034
19/3	1047

## Lane Saturation Flows

Junction: M1 Junction 15								
Lane	Lane Width (m)	Gradient	Nearside Lane	Allowed Turns	Turning Radius (m)	Turning Prop.	Sat Flow (PCU/Hr)	Flared Sat Flow (PCU/Hr)
1/1 (M1 Southbound Offslip)	3.65	0.00	Y	Arm 2 Left	Inf	100.0 %	1980	1980
1/2 (M1 Southbound Offslip)	3.65	0.00	N	Arm 2 Left	Inf	100.0 %	2120	2120
1/3 (M1 Southbound Offslip)	3.65	0.00	N	Arm 2 Left	Inf	100.0 %	2120	2120
1/4 (M1 Southbound Offslip Lane 4)	This lane uses a directly entered Saturation Flow						4000	4000
2/1 (A45 Northbound Lane 1)	Infinite Saturation Flow						Inf	Inf
2/2 (A45 Northbound Lane 2)	Infinite Saturation Flow						Inf	Inf
2/3 (A45 Northbound Lane 3)	Infinite Saturation Flow						Inf	Inf
3/1	This lane uses a directly entered Saturation Flow						1900	1900
3/2	This lane uses a directly entered Saturation Flow						1900	1900
3/3	This lane uses a directly entered Saturation Flow						1900	1900
3/4	This lane uses a directly entered Saturation Flow						1900	1900
4/1 (A45 Southbound)	3.65	0.00	Y	Arm 5 Left	Inf	16.5 %	1980	1980
				Arm 18 Ahead	Inf	83.5 %		
4/2 (A45 Southbound)	3.65	0.00	N	Arm 18 Ahead	Inf	100.0 %	2120	2120
4/3 (A45 Southbound)	3.65	0.00	N	Arm 19 Ahead	Inf	100.0 %	2120	2120
4/4 (A45 Southbound)	3.65	0.00	N	Arm 19 Ahead	Inf	100.0 %	2120	2120
4/5 (A45 Southbound)	3.65	0.00	N	Arm 19 Ahead	Inf	100.0 %	2120	2120
5/1 (Saxon Avenue Exit Lane 1)	Infinite Saturation Flow						Inf	Inf
6/1 (M1 Northbound Circulatory Lane 1)	This lane uses a directly entered Saturation Flow						2120	2120
6/2 (M1 Northbound Circulatory Lane 2)	This lane uses a directly entered Saturation Flow						2120	2120
6/3 (M1 Northbound Circulatory Lane 3)	This lane uses a directly entered Saturation Flow						2120	2120
6/4 (M1 Northbound Circulatory Lane 4)	This lane uses a directly entered Saturation Flow						2120	2120
7/1 (M1 Southbound Onslip Lane 1)	Infinite Saturation Flow						Inf	Inf
7/2 (M1 Southbound Onslip Lane 2)	Infinite Saturation Flow						Inf	Inf

8/1 (Saxon Avenue)	3.50	0.00	Y	Arm 6 Left	Inf	13.6 %	1884	1884
				Arm 7 Left	30.00	86.4 %		
8/2 (Saxon Avenue)	3.50	0.00	N	Arm 6 Left	Inf	100.0 %	2105	2105
9/1 (M1 Northbound Offslip)	3.65	0.00	Y	Arm 10 Left	Inf	100.0 %	1980	1980
9/2 (M1 Northbound Offslip)	3.65	0.00	N	Arm 16 Ahead	Inf	100.0 %	2120	2120
9/3 (M1 Northbound Offslip)	3.65	0.00	N	Arm 16 Ahead	Inf	100.0 %	2120	2120
9/4 (M1 Northbound Offslip)	3.65	0.00	N	Arm 16 Ahead	Inf	100.0 %	2120	2120
10/1	Infinite Saturation Flow						Inf	Inf
10/2	Infinite Saturation Flow						Inf	Inf
11/1	This lane uses a directly entered Saturation Flow						1900	1900
11/2	This lane uses a directly entered Saturation Flow						1900	1900
12/1 (Toucan Crossing)	3.80	0.00	Y	Arm 14 Ahead	Inf	100.0 %	1995	1995
12/2 (Toucan Crossing)	3.80	0.00	Y	Arm 14 Ahead	Inf	100.0 %	1995	1995
13/1 (A508 Northampton Rd)	3.65	0.00	Y	Arm 12 Ahead	Inf	100.0 %	1980	1980
13/2 (A508 Northampton Rd)	3.65	0.00	Y	Arm 12 Ahead	Inf	100.0 %	1980	1980
13/3 (A508 Northampton Rd)	3.65	0.00	N	Arm 17 Ahead	Inf	100.0 %	2120	2120
13/4 (A508 Northampton Rd)	3.65	0.00	N	Arm 17 Ahead	Inf	100.0 %	2120	2120
13/5 (A508 Northampton Rd)	3.65	0.00	N	Arm 17 Ahead	Inf	100.0 %	2120	2120
14/1	Infinite Saturation Flow						Inf	Inf
14/2	Infinite Saturation Flow						Inf	Inf
15/1	This lane uses a directly entered Saturation Flow						2000	2000
15/2	This lane uses a directly entered Saturation Flow						2000	2000
15/3	This lane uses a directly entered Saturation Flow						2000	2000
15/4	This lane uses a directly entered Saturation Flow						2000	2000
16/1	This lane uses a directly entered Saturation Flow						2000	2000
16/2	This lane uses a directly entered Saturation Flow						2000	2000
16/3	This lane uses a directly entered Saturation Flow						2000	2000
17/1	This lane uses a directly entered Saturation Flow						2000	2000
17/2	This lane uses a directly entered Saturation Flow						2000	2000
17/3	This lane uses a directly entered Saturation Flow						2000	2000
18/1	This lane uses a directly entered Saturation Flow						2000	2000
18/2	This lane uses a directly entered Saturation Flow						2000	2000
19/1	This lane uses a directly entered Saturation Flow						2000	2000
19/2	This lane uses a directly entered Saturation Flow						2120	2120
19/3	This lane uses a directly entered Saturation Flow						2120	2120

**Scenario 4: '2031 With additional mez - PM '** (FG4: '2031 with additional mez - PM', Plan 1: 'Network Control Plan 1')

**Traffic Flows, Desired**

**Desired Flow :**

	Destination						
	A	B	C	D	E	Tot.	
Origin	A	117	88	985	1219	1279	3688
	B	30	0	121	18	100	269
	C	1503	25	0	215	0	1743
	D	1491	13	222	50	729	2505
	E	1007	99	0	577	0	1683
	Tot.	4148	225	1328	2079	2108	9888

## Traffic Lane Flows

Lane	Scenario 4: 2031 With additional mez - PM
<b>Junction: M1 Junction 15</b>	
1/1 (short)	293
1/2 (with short)	607(In) 314(Out)
1/3 (with short)	1076(In) 400(Out)
1/4 (short)	676
2/1	1464
2/2	1403
2/3	1281
3/1	137
3/2	222
3/3	274
3/4	353
4/1 (short)	534
4/2 (with short)	1073(In) 539(Out)
4/3	866
4/4 (with short)	1749(In) 702(Out)
4/5 (short)	1047
5/1	225
6/1	1140
6/2 (with short)	1074(In) 724(Out)
6/3 (short)	350
6/4	1176
7/1	687
7/2	641
8/1	140
8/2	129
9/1 (short)	215
9/2 (with short)	716(In) 501(Out)
9/3 (with short)	1027(In) 474(Out)
9/4 (short)	553
10/1	1355
10/2	724
11/1	652

11/2	874
12/1	1016
12/2	1092
13/1 (short)	364
13/2 (with short)	729(In) 365(Out)
13/3	545
13/4 (with short)	1231(In) 593(Out)
13/5 (short)	638
14/1	1016
14/2	1092
15/1	1171
15/2	1089
15/3 (with short)	1191(In) 881(Out)
15/4 (short)	310
16/1	501
16/2	474
16/3	553
17/1	670
17/2	615
17/3	638
18/1	566
18/2	641
19/1	1140
19/2	1055
19/3	1047

## Lane Saturation Flows

Junction: M1 Junction 15								
Lane	Lane Width (m)	Gradient	Nearside Lane	Allowed Turns	Turning Radius (m)	Turning Prop.	Sat Flow (PCU/Hr)	Flared Sat Flow (PCU/Hr)
1/1 (M1 Southbound Offslip)	3.65	0.00	Y	Arm 2 Left	Inf	100.0 %	1980	1980
1/2 (M1 Southbound Offslip)	3.65	0.00	N	Arm 2 Left	Inf	100.0 %	2120	2120
1/3 (M1 Southbound Offslip)	3.65	0.00	N	Arm 2 Left	Inf	100.0 %	2120	2120
1/4 (M1 Southbound Offslip Lane 4)	This lane uses a directly entered Saturation Flow						4000	4000
2/1 (A45 Northbound Lane 1)	Infinite Saturation Flow						Inf	Inf
2/2 (A45 Northbound Lane 2)	Infinite Saturation Flow						Inf	Inf
2/3 (A45 Northbound Lane 3)	Infinite Saturation Flow						Inf	Inf
3/1	This lane uses a directly entered Saturation Flow						1900	1900
3/2	This lane uses a directly entered Saturation Flow						1900	1900
3/3	This lane uses a directly entered Saturation Flow						1900	1900
3/4	This lane uses a directly entered Saturation Flow						1900	1900
4/1 (A45 Southbound)	3.65	0.00	Y	Arm 5 Left	Inf	16.5 %	1980	1980
				Arm 18 Ahead	Inf	83.5 %		
4/2 (A45 Southbound)	3.65	0.00	N	Arm 18 Ahead	Inf	100.0 %	2120	2120
4/3 (A45 Southbound)	3.65	0.00	N	Arm 19 Ahead	Inf	100.0 %	2120	2120
4/4 (A45 Southbound)	3.65	0.00	N	Arm 19 Ahead	Inf	100.0 %	2120	2120
4/5 (A45 Southbound)	3.65	0.00	N	Arm 19 Ahead	Inf	100.0 %	2120	2120
5/1 (Saxon Avenue Exit Lane 1)	Infinite Saturation Flow						Inf	Inf
6/1 (M1 Northbound Circulatory Lane 1)	This lane uses a directly entered Saturation Flow						2120	2120
6/2 (M1 Northbound Circulatory Lane 2)	This lane uses a directly entered Saturation Flow						2120	2120
6/3 (M1 Northbound Circulatory Lane 3)	This lane uses a directly entered Saturation Flow						2120	2120
6/4 (M1 Northbound Circulatory Lane 4)	This lane uses a directly entered Saturation Flow						2120	2120
7/1 (M1 Southbound Onslip Lane 1)	Infinite Saturation Flow						Inf	Inf
7/2 (M1 Southbound Onslip Lane 2)	Infinite Saturation Flow						Inf	Inf

8/1 (Saxon Avenue)	3.50	0.00	Y	Arm 6 Left	Inf	13.6 %	1884	1884
				Arm 7 Left	30.00	86.4 %		
8/2 (Saxon Avenue)	3.50	0.00	N	Arm 6 Left	Inf	100.0 %	2105	2105
9/1 (M1 Northbound Offslip)	3.65	0.00	Y	Arm 10 Left	Inf	100.0 %	1980	1980
9/2 (M1 Northbound Offslip)	3.65	0.00	N	Arm 16 Ahead	Inf	100.0 %	2120	2120
9/3 (M1 Northbound Offslip)	3.65	0.00	N	Arm 16 Ahead	Inf	100.0 %	2120	2120
9/4 (M1 Northbound Offslip)	3.65	0.00	N	Arm 16 Ahead	Inf	100.0 %	2120	2120
10/1	Infinite Saturation Flow						Inf	Inf
10/2	Infinite Saturation Flow						Inf	Inf
11/1	This lane uses a directly entered Saturation Flow						1900	1900
11/2	This lane uses a directly entered Saturation Flow						1900	1900
12/1 (Toucan Crossing)	3.80	0.00	Y	Arm 14 Ahead	Inf	100.0 %	1995	1995
12/2 (Toucan Crossing)	3.80	0.00	Y	Arm 14 Ahead	Inf	100.0 %	1995	1995
13/1 (A508 Northampton Rd)	3.65	0.00	Y	Arm 12 Ahead	Inf	100.0 %	1980	1980
13/2 (A508 Northampton Rd)	3.65	0.00	Y	Arm 12 Ahead	Inf	100.0 %	1980	1980
13/3 (A508 Northampton Rd)	3.65	0.00	N	Arm 17 Ahead	Inf	100.0 %	2120	2120
13/4 (A508 Northampton Rd)	3.65	0.00	N	Arm 17 Ahead	Inf	100.0 %	2120	2120
13/5 (A508 Northampton Rd)	3.65	0.00	N	Arm 17 Ahead	Inf	100.0 %	2120	2120
14/1	Infinite Saturation Flow						Inf	Inf
14/2	Infinite Saturation Flow						Inf	Inf
15/1	This lane uses a directly entered Saturation Flow						2000	2000
15/2	This lane uses a directly entered Saturation Flow						2000	2000
15/3	This lane uses a directly entered Saturation Flow						2000	2000
15/4	This lane uses a directly entered Saturation Flow						2000	2000
16/1	This lane uses a directly entered Saturation Flow						2000	2000
16/2	This lane uses a directly entered Saturation Flow						2000	2000
16/3	This lane uses a directly entered Saturation Flow						2000	2000
17/1	This lane uses a directly entered Saturation Flow						2000	2000
17/2	This lane uses a directly entered Saturation Flow						2000	2000
17/3	This lane uses a directly entered Saturation Flow						2000	2000
18/1	This lane uses a directly entered Saturation Flow						2000	2000
18/2	This lane uses a directly entered Saturation Flow						2000	2000
19/1	This lane uses a directly entered Saturation Flow						2000	2000
19/2	This lane uses a directly entered Saturation Flow						2120	2120
19/3	This lane uses a directly entered Saturation Flow						2120	2120

**Scenario 1: '2031 Background - AM'** (FG1: '2031 background - AM', Plan 1: 'Network Control Plan 1')

**C1 - Eastside Controller**

**Stage Sequence Diagram**

**Stage Stream: 1**

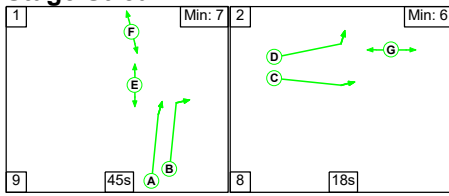

**Stage Stream: 2**

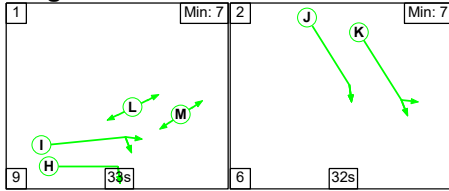

**Stage Stream: 3**

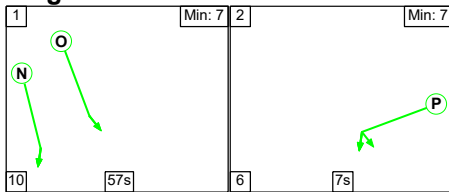

**Stage Timings**

**Stage Stream: 1**

Stage	1	2
Duration	45	18
Change Point	67	41

**Stage Stream: 2**

Stage	1	2
Duration	33	32
Change Point	30	72

**Stage Stream: 3**

Stage	1	2
Duration	57	7
Change Point	47	34

# Signal Timings Diagram

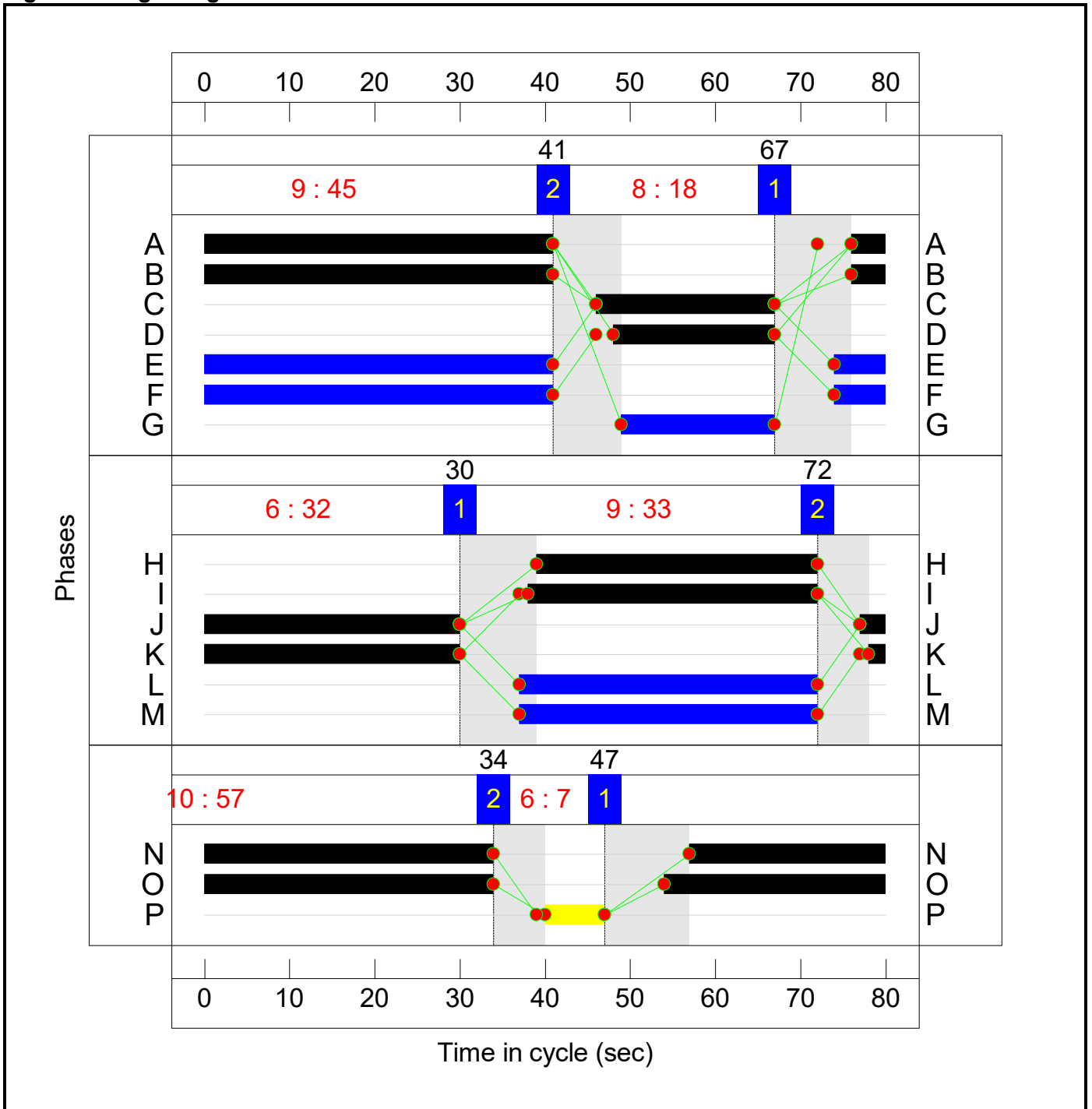

## C2 - Westside Controller Stage Sequence Diagram Stage Stream: 1

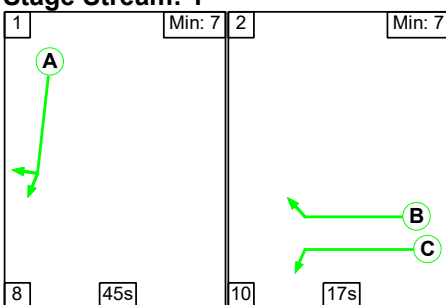

### Stage Stream: 2

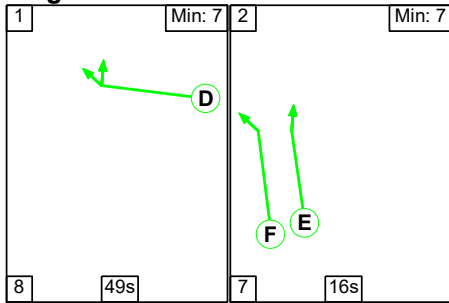

### Stage Stream: 3

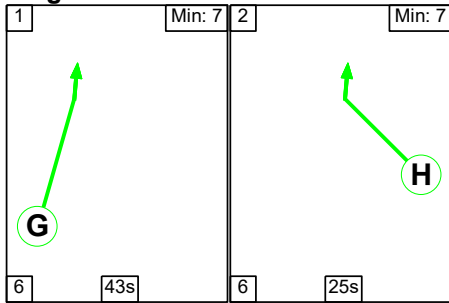

### Stage Stream: 4

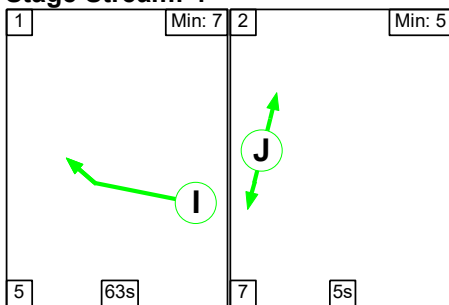

### Stage Timings

#### Stage Stream: 1

Stage	1	2
Duration	45	17
Change Point	24	77

#### Stage Stream: 2

Stage	1	2
Duration	49	16
Change Point	10	67

#### Stage Stream: 3

Stage	1	2
Duration	43	25
Change Point	35	4

#### Stage Stream: 4

Stage	1	2
Duration	63	5
Change Point	20	8

# Signal Timings Diagram

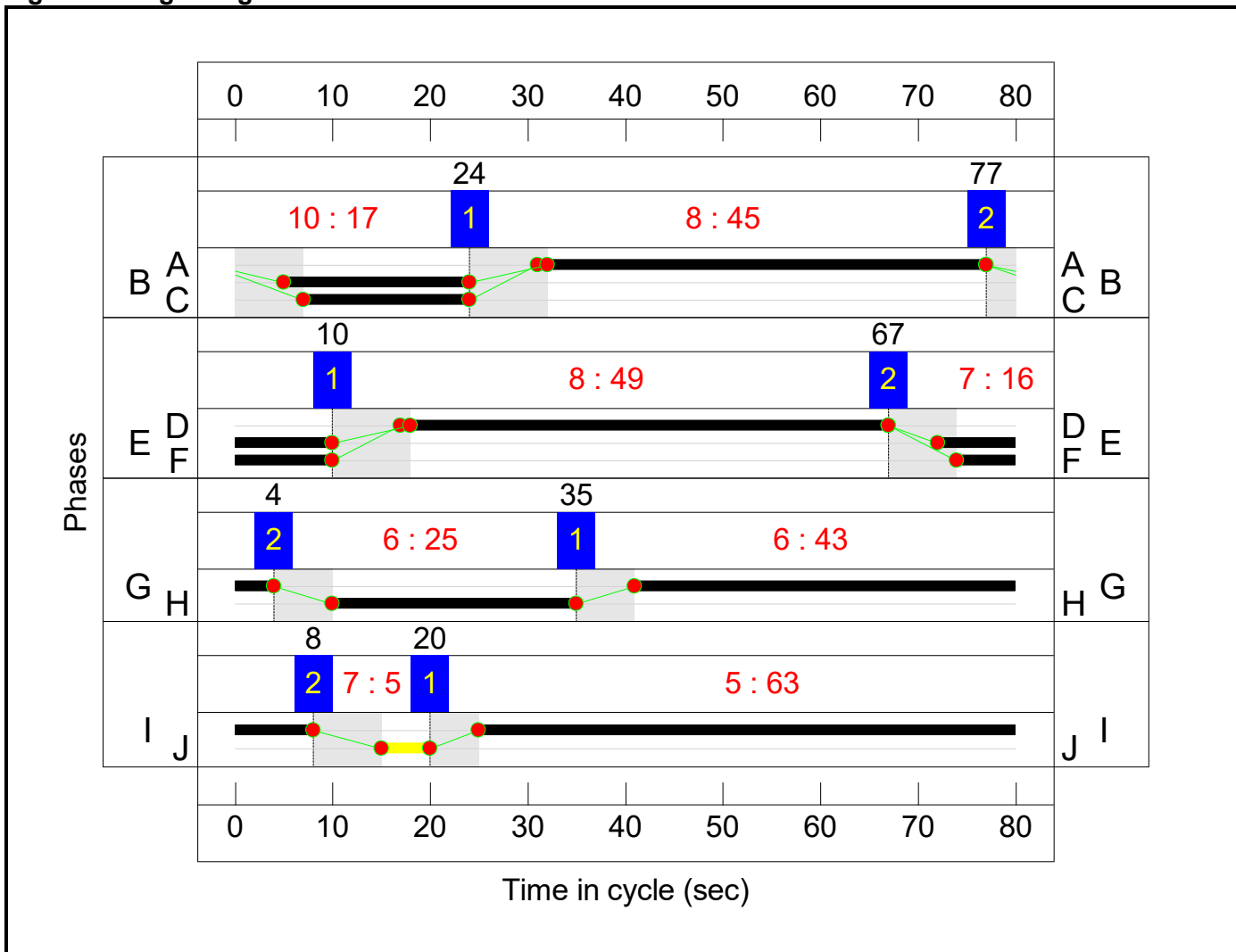

## Network Results

Item	Lane Description	Lane Type	Controller Stream	Position In Filtered Route	Full Phase	Arrow Phase	Num Greens	Total Green (s)	Arrow Green (s)	Demand Flow (pcu)	Sat Flow (pcu/Hr)	Capacity (pcu)	Deg Sat (%)
<b>Network: M1 Junction 15 impact with additional mezzanine</b>	-	-	N/A	-	-		-	-	-	-	-	-	<b>110.6%</b>
<b>M1 Junction 15</b>	-	-	N/A	-	-		-	-	-	-	-	-	<b>110.6%</b>
1/2+1/1	M1 Southbound Offslip Left	U	1:1	N/A	C1:D		1	19	-	779	2120:1980	530+495	76.0 : 76.0%
1/3+1/4	M1 Southbound Offslip Left Ahead	U	1:1	N/A	C1:D C1:C		1	19:21	-	1354	2120:4000	530+1100	85.1 : 82.1%
3/1	Ahead	U	1:2	N/A	C1:I		1	34	-	192	1900	831	22.5%
3/2	Right	U	1:2	N/A	C1:I		1	34	-	198	1900	831	23.8%
3/3	Right	U	1:2	N/A	C1:H		1	33	-	319	1900	808	39.5%
3/4	Right	U	1:2	N/A	C1:H		1	33	-	499	1900	808	61.8%
4/2+4/1	A45 Southbound Left Ahead	U	1:2	N/A	C1:K		1	32	-	991	2120:1980	875+817	56.9 : 60.4%
4/3	A45 Southbound Ahead	U	1:2	N/A	C1:J		1	33	-	944	2120	901	104.8%
4/4+4/5	A45 Southbound Ahead	U	1:2	N/A	C1:J		1	33	-	1910	2120:2120	901+901	106.1 : 105.9%
6/1	M1 Northbound Circulatory Ahead	U	2:1	N/A	C2:A		1	45	-	1263	2120	1219	100.1%
6/2+6/3	M1 Northbound Circulatory Ahead Right	U	2:1	N/A	C2:A		1	45	-	1503	2120:2120	673+828	98.8 : 94.6%
6/4	M1 Northbound Circulatory Right	U	2:1	N/A	C2:A		1	45	-	1031	2120	1219	80.2%
8/1	Saxon Avenue Left Left2	U	1:3	N/A	C1:P		1	7	-	68	1937	194	35.1%
8/2	Saxon Avenue Left	U	1:3	N/A	C1:P		1	7	-	77	2105	210	36.6%
9/2+9/1	M1 Northbound Offslip Left Ahead	U	2:1	N/A	C2:B C2:C		1	19:17	-	914	2120:1980	530+299	110.2 : 110.2%

9/3+9/4	M1 Northbound Offslip Ahead	U	2:1	N/A	C2:B		1	19	-	1172	2120:2120	530+530	110.6 : 110.6%
11/1	Ahead	U	2:2	N/A	C2:D		1	49	-	900	1900	1187	71.6%
11/2	Ahead Right	U	2:2	N/A	C2:D		1	49	-	960	1900	1187	76.7%
12/1	Toucan Crossing Ahead	U	2:4	N/A	C2:I		1	63	-	1224	1995	1596	73.6%
12/2	Toucan Crossing Ahead	U	2:4	N/A	C2:I		1	63	-	1209	1995	1596	72.8%
13/2+13/1	A508 Northampton Rd Ahead	U	2:2	N/A	C2:F		1	16	-	649	1980:1980	421+421	77.2 : 77.0%
13/3	A508 Northampton Rd Ahead	U	2:2	N/A	C2:E		1	18	-	304	2120	503	60.4%
13/4+13/5	A508 Northampton Rd Ahead	U	2:2	N/A	C2:E		1	18	-	665	2120:2120	503+503	65.3 : 66.7%
15/1	Ahead	U	1:1	N/A	C1:A		1	45	-	923	2000	1150	75.4%
15/2	Ahead	U	1:1	N/A	C1:A		1	45	-	915	2000	1150	74.7%
15/3+15/4	Ahead Right	U	1:1	N/A	C1:A C1:B		1	45	-	963	2000:2000	941+436	64.5 : 68.8%
16/1	Right	U	2:3	N/A	C2:H		1	25	-	584	2000	650	81.5%
16/2	Right	U	2:3	N/A	C2:H		1	25	-	586	2000	650	81.5%
16/3	Right	U	2:3	N/A	C2:H		1	25	-	586	2000	650	81.5%
17/1	Ahead	U	2:3	N/A	C2:G		1	43	-	339	2000	1100	30.6%
17/2	Ahead	U	2:3	N/A	C2:G		1	43	-	329	2000	1100	29.9%
17/3	Ahead	U	2:3	N/A	C2:G		1	43	-	377	2000	1100	34.3%
18/1	Ahead	U	1:3	N/A	C1:O		1	60	-	560	2000	1525	36.7%
18/2	Ahead	U	1:3	N/A	C1:O		1	60	-	597	2000	1525	39.1%
19/1	Ahead	U	1:3	N/A	C1:N		1	57	-	1263	2000	1450	84.1%
19/2	Ahead	U	1:3	N/A	C1:N		1	57	-	1455	2120	1537	91.1%
19/3	Ahead	U	1:3	N/A	C1:N		1	57	-	954	2120	1537	58.6%

Item	Arriving (pcu)	Leaving (pcu)	Turners In Gaps (pcu)	Turners When Unopposed (pcu)	Turners In Intergreen (pcu)	Uniform Delay (pcuHr)	Rand + Oversat Delay (pcuHr)	Storage Area Uniform Delay (pcuHr)	Total Delay (pcuHr)	Av. Delay Per PCU (s/pcu)	Max. Back of Uniform Queue (pcu)	Rand + Oversat Queue (pcu)	Mean Max Queue (pcu)
<b>Network: M1 Junction 15 impact with additional mezzanine</b>	-	-	0	0	0	117.7	208.3	0.0	326.0	-	-	-	-
<b>M1 Junction 15</b>	-	-	0	0	0	117.7	208.3	0.0	326.0	-	-	-	-
1/2+1/1	779	779	-	-	-	6.0	1.6	-	7.6 (3.9+3.7)	35.0 (35.0:35.0)	8.3	1.6	9.8
1/3+1/4	1354	1354	-	-	-	10.4	2.4	-	12.8 (4.4+8.4)	34.0 (35.0:33.6)	9.5	2.4	11.9
3/1	187	187	-	-	-	0.3	0.0	-	0.3	5.3	1.3	0.0	1.3
3/2	198	198	-	-	-	1.8	0.0	-	1.8	32.0	4.4	0.0	4.4
3/3	319	319	-	-	-	0.3	0.0	-	0.3	2.9	0.7	0.0	0.7
3/4	499	499	-	-	-	0.2	0.0	-	0.2	1.4	5.0	0.0	5.0
4/2+4/1	991	991	-	-	-	5.0	0.7	-	5.7 (2.9+2.9)	20.8 (20.6:21.0)	8.5	0.7	9.2
4/3	944	901	-	-	-	7.8	29.5	-	37.3	142.1	21.9	29.5	51.4
4/4+4/5	1910	1802	-	-	-	16.5	61.7	-	78.3 (39.7+38.6)	147.5 (149.4:145.6)	22.5	61.7	84.2
6/1	1220	1219	-	-	-	6.8	0.5	-	7.3	21.5	22.2	0.5	22.7
6/2+6/3	1448	1448	-	-	-	6.8	0.0	-	6.8 (3.3+3.6)	17.0 (17.6:16.5)	18.9	0.0	18.9
6/4	978	978	-	-	-	4.9	0.0	-	4.9	18.1	21.1	0.0	21.1
8/1	68	68	-	-	-	0.6	0.3	-	0.9	47.9	1.4	0.3	1.7
8/2	77	77	-	-	-	0.7	0.3	-	1.0	47.1	1.6	0.3	1.9
9/2+9/1	914	860	-	-	-	9.7	47.1	-	56.8 (37.1+19.7)	223.6 (228.8:214.4)	14.2	47.1	61.3
9/3+9/4	1172	1060	-	-	-	14.2	60.8	-	75.0 (37.5+37.5)	230.5 (230.5:230.5)	14.3	60.8	75.1
11/1	851	851	-	-	-	1.5	0.0	-	1.5	6.6	12.3	0.0	12.3
11/2	911	911	-	-	-	1.8	0.0	-	1.8	7.3	4.4	0.0	4.4
12/1	1175	1175	-	-	-	0.3	0.0	-	0.3	0.8	3.4	0.0	3.4



**Scenario 2: '2031 With additional mez - AM' (FG3: '2031 with additional mez - AM', Plan 1: 'Network Control Plan 1')**

**C1 - Eastside Controller**

**Stage Sequence Diagram**

**Stage Stream: 1**

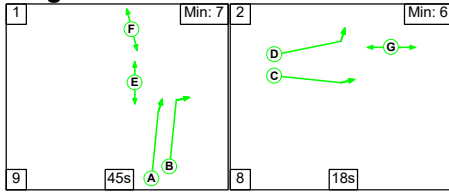

**Stage Stream: 2**

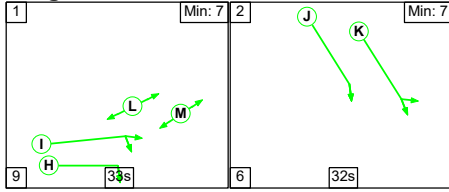

**Stage Stream: 3**

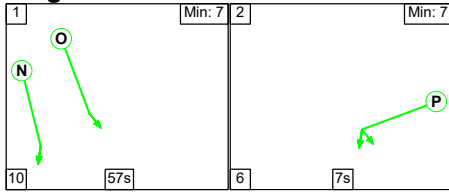

**Stage Timings**

**Stage Stream: 1**

Stage	1	2
Duration	45	18
Change Point	67	41

**Stage Stream: 2**

Stage	1	2
Duration	33	32
Change Point	30	72

**Stage Stream: 3**

Stage	1	2
Duration	57	7
Change Point	47	34

# Signal Timings Diagram

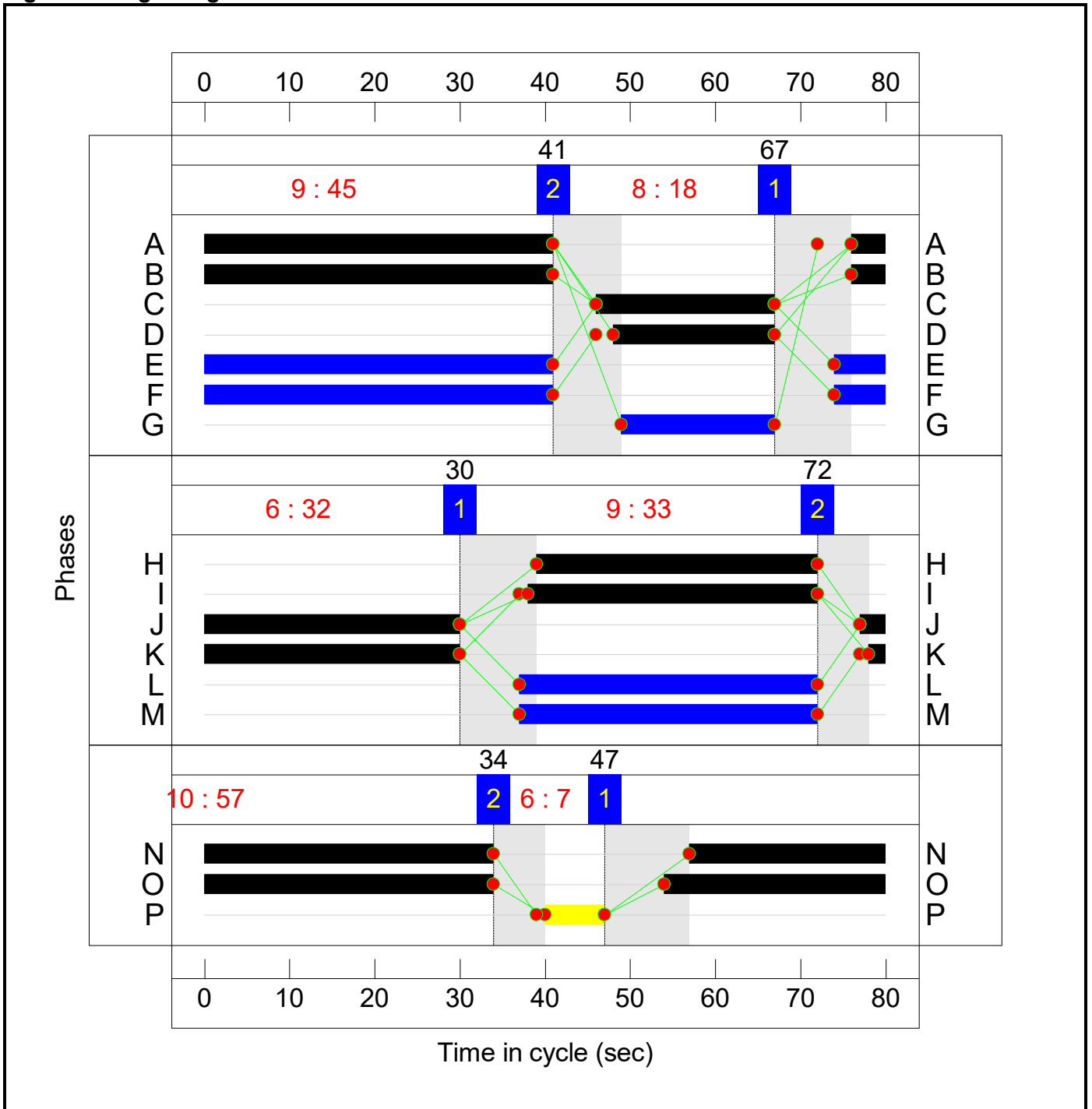

## C2 - Westside Controller Stage Sequence Diagram Stage Stream: 1

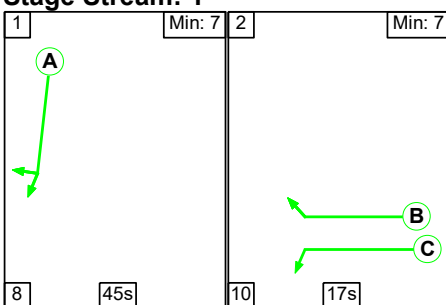

### Stage Stream: 2

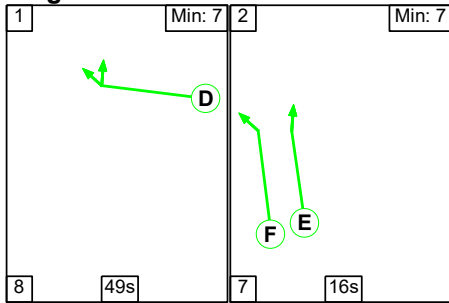

### Stage Stream: 3

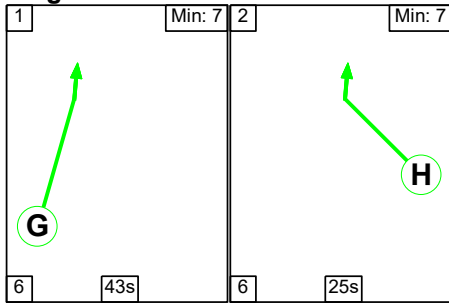

### Stage Stream: 4

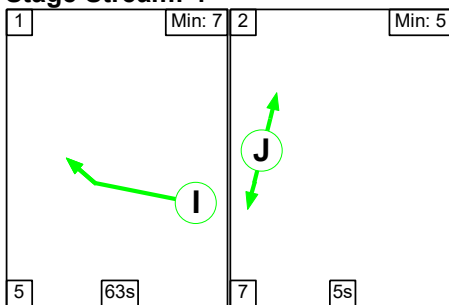

### Stage Timings

#### Stage Stream: 1

Stage	1	2
Duration	45	17
Change Point	24	77

#### Stage Stream: 2

Stage	1	2
Duration	49	16
Change Point	10	67

#### Stage Stream: 3

Stage	1	2
Duration	43	25
Change Point	35	4

#### Stage Stream: 4

Stage	1	2
Duration	63	5
Change Point	20	8

# Signal Timings Diagram

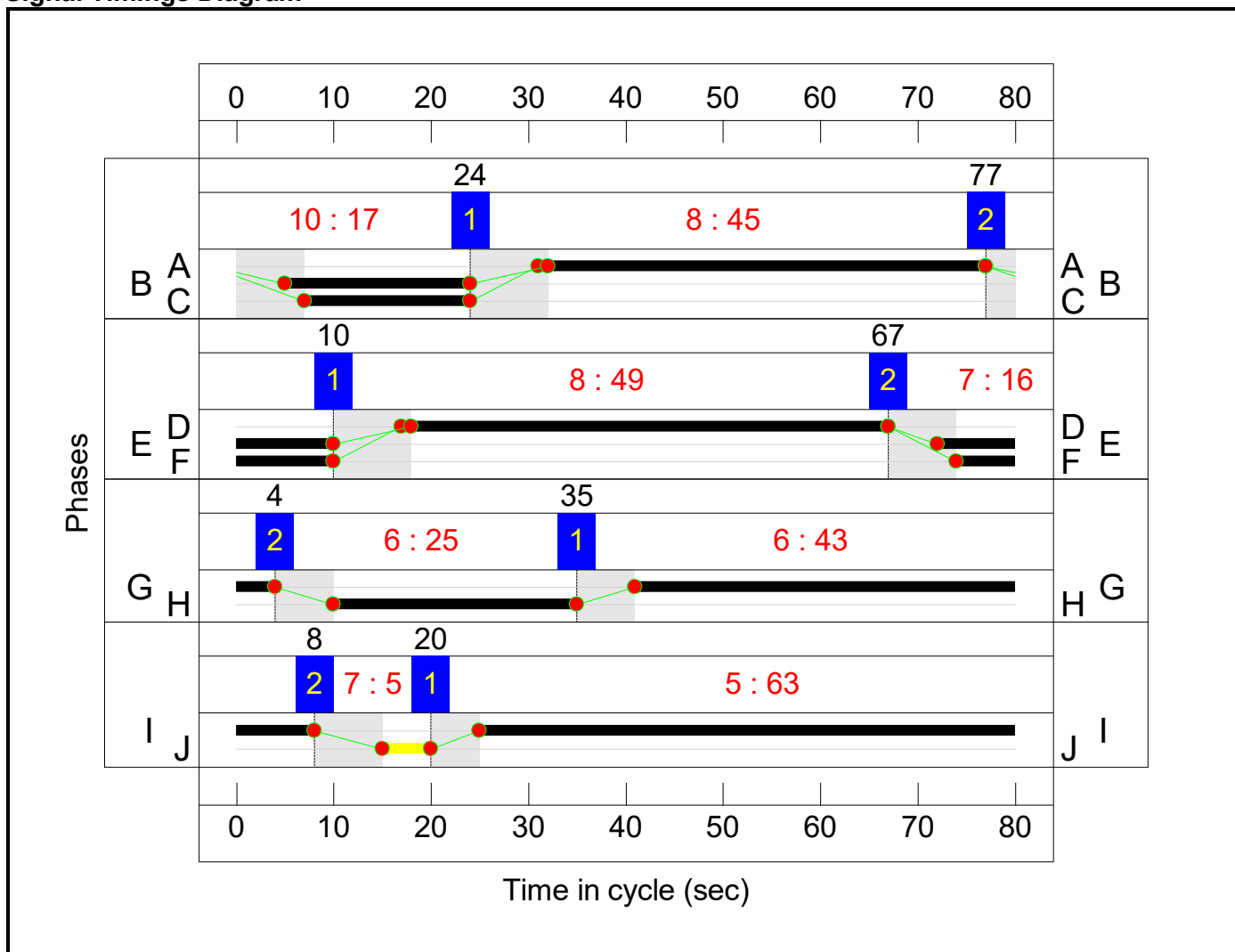

## Network Results

Item	Lane Description	Lane Type	Controller Stream	Position In Filtered Route	Full Phase	Arrow Phase	Num Greens	Total Green (s)	Arrow Green (s)	Demand Flow (pcu)	Sat Flow (pcu/Hr)	Capacity (pcu)	Deg Sat (%)
<b>Network: M1 Junction 15 impact with additional mezzanine</b>	-	-	N/A	-	-		-	-	-	-	-	-	<b>110.6%</b>
<b>M1 Junction 15</b>	-	-	N/A	-	-		-	-	-	-	-	-	<b>110.6%</b>
1/2+1/1	M1 Southbound Offslip Left	U	1:1	N/A	C1:D		1	19	-	785	2120:1980	530+495	76.6 : 76.6%
1/3+1/4	M1 Southbound Offslip Left Ahead	U	1:1	N/A	C1:D C1:C		1	19:21	-	1371	2120:4000	530+1100	84.0 : 84.2%
3/1	Ahead	U	1:2	N/A	C1:I		1	34	-	192	1900	831	22.5%
3/2	Right	U	1:2	N/A	C1:I		1	34	-	208	1900	831	25.0%
3/3	Right	U	1:2	N/A	C1:H		1	33	-	319	1900	808	39.5%
3/4	Right	U	1:2	N/A	C1:H		1	33	-	522	1900	808	64.6%
4/2+4/1	A45 Southbound Left Ahead	U	1:2	N/A	C1:K		1	32	-	991	2120:1980	875+817	56.9 : 60.4%
4/3	A45 Southbound Ahead	U	1:2	N/A	C1:J		1	33	-	956	2120	901	106.1%
4/4+4/5	A45 Southbound Ahead	U	1:2	N/A	C1:J		1	33	-	1935	2120:2120	901+901	107.4 : 107.3%
6/1	M1 Northbound Circulatory Ahead	U	2:1	N/A	C2:A		1	45	-	1275	2120	1219	100.1%
6/2+6/3	M1 Northbound Circulatory Ahead Right	U	2:1	N/A	C2:A		1	45	-	1533	2120:2120	720+809	98.5 : 93.6%
6/4	M1 Northbound Circulatory Right	U	2:1	N/A	C2:A		1	45	-	1049	2120	1219	80.6%
8/1	Saxon Avenue Left Left2	U	1:3	N/A	C1:P		1	7	-	63	1934	193	32.6%
8/2	Saxon Avenue Left	U	1:3	N/A	C1:P		1	7	-	82	2105	210	39.0%
9/2+9/1	M1 Northbound Offslip Left Ahead	U	2:1	N/A	C2:B C2:C		1	19:17	-	941	2120:1980	530+330	110.2 : 108.2%

9/3+9/4	M1 Northbound Offslip Ahead	U	2:1	N/A	C2:B		1	19	-	1172	2120:2120	530+530	110.6 : 110.6%
11/1	Ahead	U	2:2	N/A	C2:D		1	49	-	913	1900	1187	71.8%
11/2	Ahead Right	U	2:2	N/A	C2:D		1	49	-	947	1900	1187	74.7%
12/1	Toucan Crossing Ahead	U	2:4	N/A	C2:I		1	63	-	1242	1995	1596	74.0%
12/2	Toucan Crossing Ahead	U	2:4	N/A	C2:I		1	63	-	1200	1995	1596	71.6%
13/2+13/1	A508 Northampton Rd Ahead	U	2:2	N/A	C2:F		1	16	-	658	1980:1980	421+421	78.2 : 78.2%
13/3	A508 Northampton Rd Ahead	U	2:2	N/A	C2:E		1	18	-	311	2120	503	61.8%
13/4+13/5	A508 Northampton Rd Ahead	U	2:2	N/A	C2:E		1	18	-	683	2120:2120	503+503	67.1 : 68.5%
15/1	Ahead	U	1:1	N/A	C1:A		1	45	-	930	2000	1150	76.0%
15/2	Ahead	U	1:1	N/A	C1:A		1	45	-	924	2000	1150	75.5%
15/3+15/4	Ahead Right	U	1:1	N/A	C1:A C1:B		1	45	-	972	2000:2000	936+449	64.7 : 69.1%
16/1	Right	U	2:3	N/A	C2:H		1	25	-	584	2000	650	81.5%
16/2	Right	U	2:3	N/A	C2:H		1	25	-	586	2000	650	81.5%
16/3	Right	U	2:3	N/A	C2:H		1	25	-	586	2000	650	81.5%
17/1	Ahead	U	2:3	N/A	C2:G		1	43	-	346	2000	1100	31.2%
17/2	Ahead	U	2:3	N/A	C2:G		1	43	-	338	2000	1100	30.7%
17/3	Ahead	U	2:3	N/A	C2:G		1	43	-	386	2000	1100	35.1%
18/1	Ahead	U	1:3	N/A	C1:O		1	60	-	565	2000	1525	37.0%
18/2	Ahead	U	1:3	N/A	C1:O		1	60	-	602	2000	1525	39.5%
19/1	Ahead	U	1:3	N/A	C1:N		1	57	-	1275	2000	1450	84.1%
19/2	Ahead	U	1:3	N/A	C1:N		1	57	-	1490	2120	1537	92.6%
19/3	Ahead	U	1:3	N/A	C1:N		1	57	-	967	2120	1537	58.6%

Item	Arriving (pcu)	Leaving (pcu)	Turners In Gaps (pcu)	Turners When Unopposed (pcu)	Turners In Intergreen (pcu)	Uniform Delay (pcuHr)	Rand + Oversat Delay (pcuHr)	Storage Area Uniform Delay (pcuHr)	Total Delay (pcuHr)	Av. Delay Per PCU (s/pcu)	Max. Back of Uniform Queue (pcu)	Rand + Oversat Queue (pcu)	Mean Max Queue (pcu)
<b>Network: M1 Junction 15 impact with additional mezzanine</b>	-	-	0	0	0	120.8	223.6	0.0	344.4	-	-	-	-
<b>M1 Junction 15</b>	-	-	0	0	0	120.8	223.6	0.0	344.4	-	-	-	-
1/2+1/1	785	785	-	-	-	6.1	1.6	-	7.7 (4.0+3.7)	35.2 (35.2:35.2)	8.3	1.6	10.0
1/3+1/4	1371	1371	-	-	-	10.6	2.6	-	13.2 (4.4+8.8)	34.5 (35.3:34.2)	9.6	2.6	12.2
3/1	187	187	-	-	-	0.3	0.0	-	0.3	5.3	1.3	0.0	1.3
3/2	208	208	-	-	-	1.9	0.0	-	1.9	32.3	4.6	0.0	4.6
3/3	319	319	-	-	-	0.3	0.0	-	0.3	2.9	0.7	0.0	0.7
3/4	522	522	-	-	-	0.2	0.0	-	0.2	1.6	6.2	0.0	6.2
4/2+4/1	991	991	-	-	-	5.0	0.7	-	5.7 (2.9+2.9)	20.8 (20.6:21.0)	8.5	0.7	9.2
4/3	956	901	-	-	-	8.3	34.4	-	42.8	161.0	22.5	34.4	56.9
4/4+4/5	1935	1802	-	-	-	17.7	73.1	-	90.8 (45.7+45.1)	169.0 (169.9:168.0)	23.0	73.1	96.1
6/1	1220	1219	-	-	-	6.8	0.5	-	7.3	21.5	22.2	0.5	22.7
6/2+6/3	1466	1466	-	-	-	7.2	0.0	-	7.2 (3.6+3.6)	17.7 (18.4:17.0)	19.5	0.0	19.5
6/4	983	983	-	-	-	4.9	0.0	-	4.9	18.1	21.8	0.0	21.8
8/1	63	63	-	-	-	0.6	0.2	-	0.8	47.3	1.3	0.2	1.5
8/2	82	82	-	-	-	0.8	0.3	-	1.1	47.7	1.7	0.3	2.0
9/2+9/1	941	887	-	-	-	9.9	45.7	-	55.6 (37.2+18.4)	212.7 (229.4:185.4)	14.2	45.7	59.9
9/3+9/4	1172	1060	-	-	-	14.2	60.8	-	75.0 (37.5+37.5)	230.5 (230.5:230.5)	14.3	60.8	75.1
11/1	852	852	-	-	-	1.5	0.0	-	1.5	6.2	4.4	0.0	4.4
11/2	888	888	-	-	-	1.5	0.0	-	1.5	6.0	3.9	0.0	3.9
12/1	1181	1181	-	-	-	0.3	0.0	-	0.3	0.9	3.5	0.0	3.5

12/2	1143	1143	-	-	-	0.2	0.0	-	0.2	0.8	3.3	0.0	3.3
13/2+13/1	658	658	-	-	-	5.4	1.8	-	7.2 (3.6+3.6)	39.4 (39.4:39.4)	6.9	1.8	8.6
13/3	311	311	-	-	-	2.4	0.8	-	3.2	36.5	6.1	0.8	6.9
13/4+13/5	683	683	-	-	-	5.3	1.0	-	6.3 (3.1+3.2)	33.2 (33.2:33.3)	6.9	1.0	7.9
15/1	874	874	-	-	-	0.9	0.0	-	0.9	3.9	3.2	0.0	3.2
15/2	868	868	-	-	-	1.0	0.0	-	1.0	4.1	3.1	0.0	3.1
15/3+15/4	916	916	-	-	-	1.3	0.0	-	1.3 (0.5+0.8)	4.9 (2.8:9.1)	2.5	0.0	2.5
16/1	530	530	-	-	-	0.1	0.0	-	0.1	0.6	0.7	0.0	0.7
16/2	530	530	-	-	-	0.1	0.0	-	0.1	0.6	0.7	0.0	0.7
16/3	530	530	-	-	-	0.1	0.0	-	0.1	0.6	0.7	0.0	0.7
17/1	344	344	-	-	-	1.1	0.0	-	1.1	11.8	2.6	0.0	2.6
17/2	338	338	-	-	-	1.4	0.0	-	1.4	14.8	3.1	0.0	3.1
17/3	386	386	-	-	-	1.7	0.0	-	1.7	15.7	4.1	0.0	4.1
18/1	565	565	-	-	-	0.3	0.0	-	0.3	1.7	2.4	0.0	2.4
18/2	602	602	-	-	-	0.3	0.0	-	0.3	1.8	2.4	0.0	2.4
19/1	1220	1220	-	-	-	1.0	0.0	-	1.0	2.8	5.1	0.0	5.1
19/2	1423	1423	-	-	-	0.2	0.0	-	0.2	0.5	0.6	0.0	0.6
19/3	901	901	-	-	-	0.2	0.0	-	0.2	0.6	0.6	0.0	0.6

C1 - Eastside Controller	Stream: 1 PRC for Signalled Lanes (%)	6.9	Total Delay for Signalled Lanes (pcuHr):	24.03	Cycle Time (s):	80
C1 - Eastside Controller	Stream: 2 PRC for Signalled Lanes (%)	-19.4	Total Delay for Signalled Lanes (pcuHr):	141.93	Cycle Time (s):	80
C1 - Eastside Controller	Stream: 3 PRC for Signalled Lanes (%)	-2.9	Total Delay for Signalled Lanes (pcuHr):	3.79	Cycle Time (s):	80
C2 - Westside Controller	Stream: 1 PRC for Signalled Lanes (%)	-22.9	Total Delay for Signalled Lanes (pcuHr):	150.07	Cycle Time (s):	80
C2 - Westside Controller	Stream: 2 PRC for Signalled Lanes (%)	15.1	Total Delay for Signalled Lanes (pcuHr):	19.62	Cycle Time (s):	80
C2 - Westside Controller	Stream: 3 PRC for Signalled Lanes (%)	10.4	Total Delay for Signalled Lanes (pcuHr):	4.47	Cycle Time (s):	80
C2 - Westside Controller	Stream: 4 PRC for Signalled Lanes (%)	21.6	Total Delay for Signalled Lanes (pcuHr):	0.52	Cycle Time (s):	80
	PRC Over All Lanes (%)	-22.9	Total Delay Over All Lanes (pcuHr):	344.43		

**Scenario 3: '2031 Background - PM'** (FG2: '2031 background - PM', Plan 1: 'Network Control Plan 1')

**C1 - Eastside Controller**

**Stage Sequence Diagram**

**Stage Stream: 1**

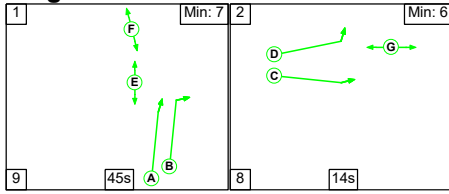

**Stage Stream: 2**

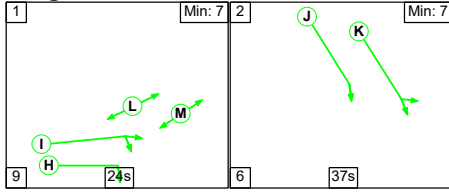

**Stage Stream: 3**

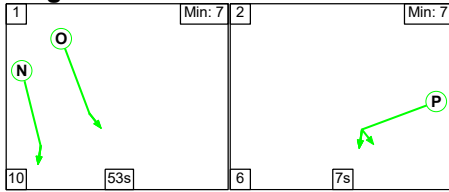

**Stage Timings**

**Stage Stream: 1**

Stage	1	2
Duration	45	14
Change Point	4	58

**Stage Stream: 2**

Stage	1	2
Duration	24	37
Change Point	47	4

**Stage Stream: 3**

Stage	1	2
Duration	53	7
Change Point	58	45

# Signal Timings Diagram

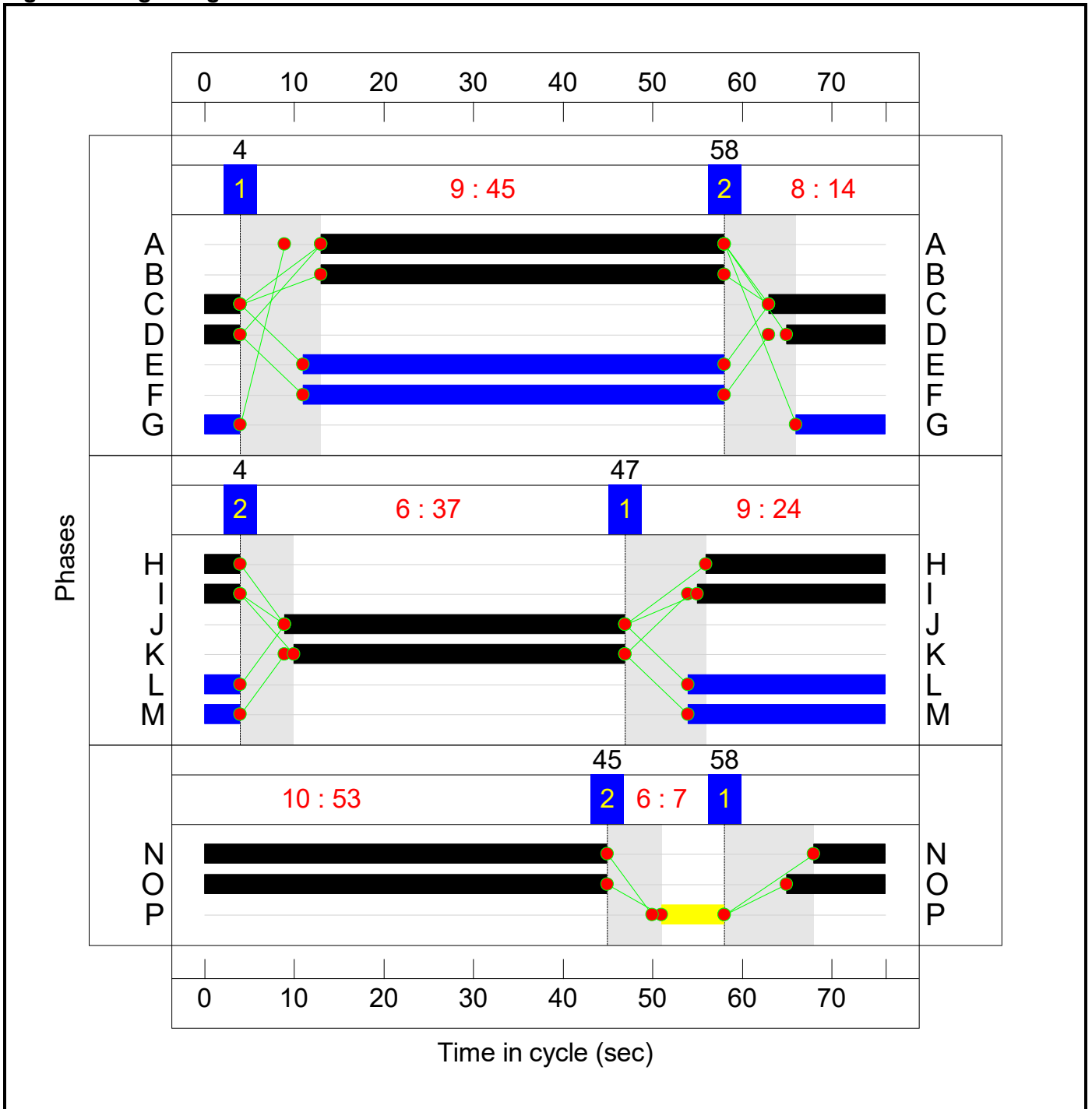

## C2 - Westside Controller Stage Sequence Diagram Stage Stream: 1

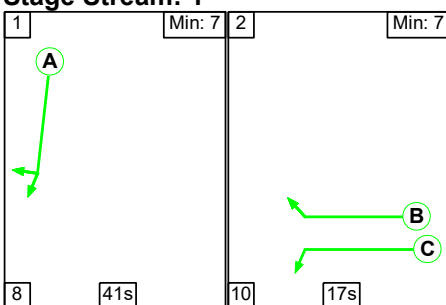

### Stage Stream: 2

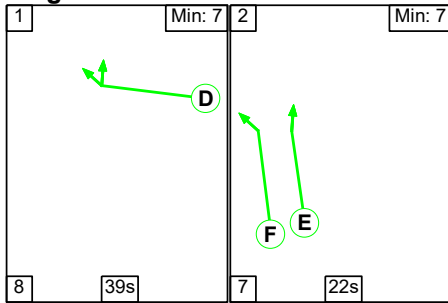

### Stage Stream: 3

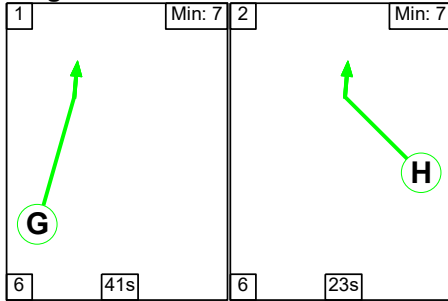

### Stage Stream: 4

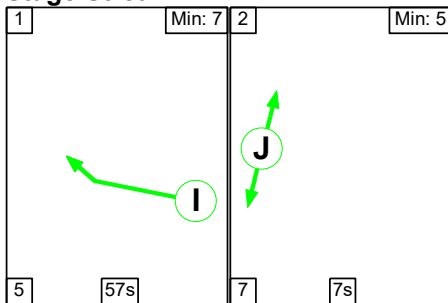

### Stage Timings

#### Stage Stream: 1

Stage	1	2
Duration	41	17
Change Point	24	73

#### Stage Stream: 2

Stage	1	2
Duration	39	22
Change Point	10	57

#### Stage Stream: 3

Stage	1	2
Duration	41	23
Change Point	33	4

#### Stage Stream: 4

Stage	1	2
Duration	57	7
Change Point	13	75

# Signal Timings Diagram

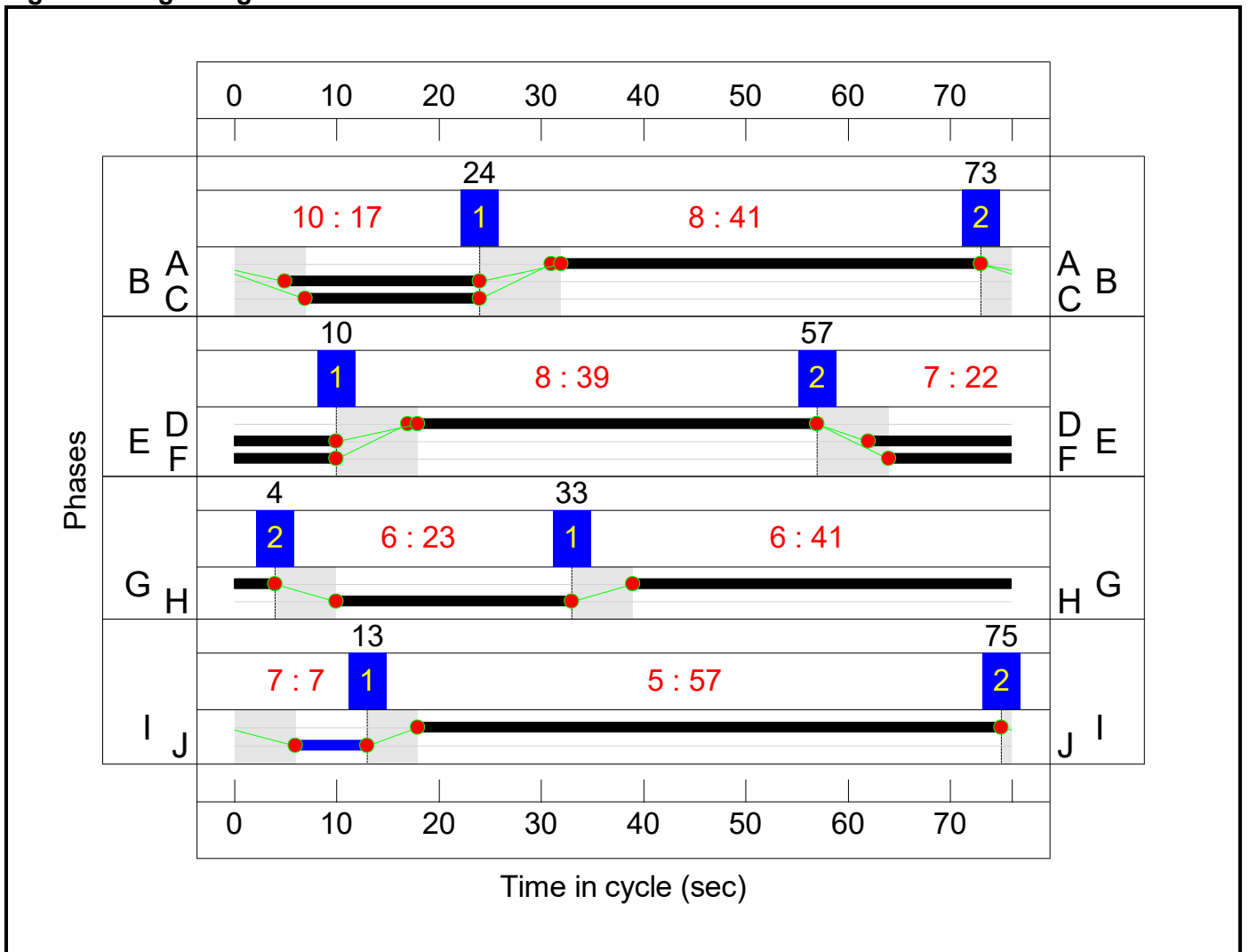

## Network Results

Item	Lane Description	Lane Type	Controller Stream	Position In Filtered Route	Full Phase	Arrow Phase	Num Greens	Total Green (s)	Arrow Green (s)	Demand Flow (pcu)	Sat Flow (pcu/Hr)	Capacity (pcu)	Deg Sat (%)
<b>Network: M1 Junction 15 impact with additional mezzanine</b>	-	-	<b>N/A</b>	-	-		-	-	-	-	-	-	<b>100.4%</b>
<b>M1 Junction 15</b>	-	-	<b>N/A</b>	-	-		-	-	-	-	-	-	<b>100.4%</b>
1/2+1/1	M1 Southbound Offslip Left	U	1:1	N/A	C1:D		1	15	-	604	2120:1980	446+417	69.9 : 70.1%
1/3+1/4	M1 Southbound Offslip Left Ahead	U	1:1	N/A	C1:D C1:C		1	15:17	-	1065	2120:4000	446+947	90.3 : 69.9%
3/1	Ahead	U	1:2	N/A	C1:I		1	25	-	137	1900	650	21.1%
3/2	Right	U	1:2	N/A	C1:I		1	25	-	199	1900	650	30.6%
3/3	Right	U	1:2	N/A	C1:H		1	24	-	261	1900	625	41.8%
3/4	Right	U	1:2	N/A	C1:H		1	24	-	352	1900	625	56.3%
4/2+4/1	A45 Southbound Left Ahead	U	1:2	N/A	C1:K		1	37	-	1073	2120:1980	1029+990	52.4 : 53.9%
4/3	A45 Southbound Ahead	U	1:2	N/A	C1:J		1	38	-	866	2120	1088	79.6%
4/4+4/5	A45 Southbound Ahead	U	1:2	N/A	C1:J		1	38	-	1729	2120:2120	832+1088	81.9 : 96.2%
6/1	M1 Northbound Circulatory Ahead	U	2:1	N/A	C2:A		1	41	-	1127	2120	1172	96.2%
6/2+6/3	M1 Northbound Circulatory Ahead Right	U	2:1	N/A	C2:A		1	41	-	1053	2120:2120	900+448	78.1 : 78.1%
6/4	M1 Northbound Circulatory Right	U	2:1	N/A	C2:A		1	41	-	1176	2120	1172	100.4%
8/1	Saxon Avenue Left Left2	U	1:3	N/A	C1:P		1	7	-	140	1884	198	70.6%
8/2	Saxon Avenue Left	U	1:3	N/A	C1:P		1	7	-	129	2105	222	58.2%
9/2+9/1	M1 Northbound Offslip Left Ahead	U	2:1	N/A	C2:B C2:C		1	19:17	-	698	2120:1980	558+232	88.4 : 88.4%

9/3+9/4	M1 Northbound Offslip Ahead	U	2:1	N/A	C2:B		1	19	-	1035	2120:2120	558+558	85.1 : 100.4%
11/1	Ahead	U	2:2	N/A	C2:D		1	39	-	656	1900	1000	65.3%
11/2	Ahead Right	U	2:2	N/A	C2:D		1	39	-	870	1900	1000	86.9%
12/1	Toucan Crossing Ahead	U	2:4	N/A	C2:I		1	57	-	1010	1995	1523	66.1%
12/2	Toucan Crossing Ahead	U	2:4	N/A	C2:I		1	57	-	1078	1995	1523	70.8%
13/2+13/1	A508 Northampton Rd Ahead	U	2:2	N/A	C2:F		1	22	-	709	1980:1980	539+537	65.9 : 65.9%
13/3	A508 Northampton Rd Ahead	U	2:2	N/A	C2:E		1	24	-	516	2120	697	74.0%
13/4+13/5	A508 Northampton Rd Ahead	U	2:2	N/A	C2:E		1	24	-	1186	2120:2120	697+697	81.9 : 88.2%
15/1	Ahead	U	1:1	N/A	C1:A		1	45	-	1139	2000	1211	94.1%
15/2	Ahead	U	1:1	N/A	C1:A		1	45	-	1062	2000	1211	87.7%
15/3+15/4	Ahead Right	U	1:1	N/A	C1:A C1:B		1	45	-	1176	2000:2000	1043+337	85.0 : 85.2%
16/1	Right	U	2:3	N/A	C2:H		1	23	-	493	2000	632	78.1%
16/2	Right	U	2:3	N/A	C2:H		1	23	-	475	2000	632	75.2%
16/3	Right	U	2:3	N/A	C2:H		1	23	-	560	2000	632	88.3%
17/1	Ahead	U	2:3	N/A	C2:G		1	41	-	646	2000	1105	58.4%
17/2	Ahead	U	2:3	N/A	C2:G		1	41	-	587	2000	1105	53.1%
17/3	Ahead	U	2:3	N/A	C2:G		1	41	-	616	2000	1105	55.7%
18/1	Ahead	U	1:3	N/A	C1:O		1	56	-	555	2000	1500	37.0%
18/2	Ahead	U	1:3	N/A	C1:O		1	56	-	629	2000	1500	41.9%
19/1	Ahead	U	1:3	N/A	C1:N		1	53	-	1127	2000	1421	79.3%
19/2	Ahead	U	1:3	N/A	C1:N		1	53	-	1034	2120	1506	68.6%
19/3	Ahead	U	1:3	N/A	C1:N		1	53	-	1047	2120	1506	69.5%

Item	Arriving (pcu)	Leaving (pcu)	Turners In Gaps (pcu)	Turners When Unopposed (pcu)	Turners In Intergreen (pcu)	Uniform Delay (pcuHr)	Rand + Oversat Delay (pcuHr)	Storage Area Uniform Delay (pcuHr)	Total Delay (pcuHr)	Av. Delay Per PCU (s/pcu)	Max. Back of Uniform Queue (pcu)	Rand + Oversat Queue (pcu)	Mean Max Queue (pcu)
<b>Network: M1 Junction 15 impact with additional mezzanine</b>	-	-	0	0	0	104.1	29.0	0.0	133.0	-	-	-	-
<b>M1 Junction 15</b>	-	-	0	0	0	104.1	29.0	0.0	133.0	-	-	-	-
1/2+1/1	604	604	-	-	-	4.7	1.2	-	5.8 (3.0+2.8)	34.7 (34.7:34.7)	6.1	1.2	7.2
1/3+1/4	1065	1065	-	-	-	8.2	1.6	-	9.8 (3.9+5.9)	33.0 (34.7:32.0)	8.3	1.6	9.9
3/1	137	137	-	-	-	0.3	0.0	-	0.3	8.1	0.9	0.0	0.9
3/2	199	199	-	-	-	1.3	0.0	-	1.3	23.3	4.1	0.0	4.1
3/3	261	261	-	-	-	0.5	0.0	-	0.5	6.9	1.2	0.0	1.2
3/4	352	352	-	-	-	0.4	0.0	-	0.4	4.4	0.7	0.0	0.7
4/2+4/1	1073	1073	-	-	-	3.8	0.6	-	4.4 (2.2+2.2)	14.8 (14.6:14.9)	7.7	0.6	8.3
4/3	866	866	-	-	-	3.7	1.9	-	5.6	23.2	14.9	1.9	16.8
4/4+4/5	1729	1729	-	-	-	7.7	4.3	-	12.0 (4.2+7.8)	25.0 (22.3:26.8)	21.2	4.3	25.6
6/1	1127	1127	-	-	-	6.6	0.0	-	6.6	21.0	23.8	0.0	23.8
6/2+6/3	1053	1053	-	-	-	6.4	0.0	-	6.4 (4.4+2.0)	21.8 (22.3:20.8)	21.5	0.0	21.5
6/4	1176	1172	-	-	-	4.8	2.2	-	7.0	21.5	25.0	2.2	27.2
8/1	140	140	-	-	-	1.3	1.2	-	2.4	62.6	2.8	1.2	4.0
8/2	129	129	-	-	-	1.2	0.7	-	1.8	51.6	2.6	0.7	3.3
9/2+9/1	698	698	-	-	-	5.1	3.5	-	8.6 (6.2+2.4)	44.4 (45.1:42.9)	9.9	3.5	13.4
9/3+9/4	1035	1033	-	-	-	7.9	6.7	-	14.6 (6.1+8.5)	50.8 (46.1:54.8)	11.9	6.7	18.5
11/1	653	653	-	-	-	3.9	0.0	-	3.9	21.6	8.8	0.0	8.8
11/2	869	869	-	-	-	4.2	0.0	-	4.2	17.2	9.1	0.0	9.1
12/1	1007	1007	-	-	-	0.5	0.0	-	0.5	1.9	2.5	0.0	2.5

12/2	1078	1078	-	-	-	0.4	0.0	-	0.4	1.5	2.4	0.0	2.4
13/2+13/1	709	709	-	-	-	4.4	1.0	-	5.4 (2.7+2.7)	27.4 (27.4:27.4)	6.3	1.0	7.3
13/3	516	516	-	-	-	3.2	1.4	-	4.6	32.4	9.6	1.4	11.0
13/4+13/5	1186	1186	-	-	-	7.8	2.8	-	10.6 (5.0+5.6)	32.2 (31.8:32.5)	12.1	2.8	14.9
15/1	1139	1139	-	-	-	3.1	0.0	-	3.1	9.7	19.0	0.0	19.0
15/2	1061	1061	-	-	-	2.4	0.0	-	2.4	8.1	17.8	0.0	17.8
15/3+15/4	1174	1174	-	-	-	1.2	0.0	-	1.2 (0.8+0.4)	3.7 (3.3:5.0)	16.1	0.0	16.1
16/1	493	493	-	-	-	0.1	0.0	-	0.1	0.5	0.6	0.0	0.6
16/2	475	475	-	-	-	0.1	0.0	-	0.1	0.5	0.5	0.0	0.5
16/3	558	558	-	-	-	0.1	0.0	-	0.1	0.6	0.7	0.0	0.7
17/1	646	646	-	-	-	1.7	0.0	-	1.7	9.4	4.8	0.0	4.8
17/2	586	586	-	-	-	2.0	0.0	-	2.0	12.4	4.6	0.0	4.6
17/3	616	616	-	-	-	2.4	0.0	-	2.4	14.2	5.2	0.0	5.2
18/1	555	555	-	-	-	0.3	0.0	-	0.3	1.9	3.2	0.0	3.2
18/2	629	629	-	-	-	0.4	0.0	-	0.4	2.0	2.9	0.0	2.9
19/1	1127	1127	-	-	-	0.8	0.0	-	0.8	2.4	3.0	0.0	3.0
19/2	1034	1034	-	-	-	0.4	0.0	-	0.4	1.4	1.9	0.0	1.9
19/3	1047	1047	-	-	-	0.9	0.0	-	0.9	3.2	3.3	0.0	3.3

C1 - Eastside Controller	Stream: 1 PRC for Signalled Lanes (%)	-4.5	Total Delay for Signalled Lanes (pcuHr)	22.24	Cycle Time (s)	76
C1 - Eastside Controller	Stream: 2 PRC for Signalled Lanes (%)	-6.9	Total Delay for Signalled Lanes (pcuHr)	24.53	Cycle Time (s)	76
C1 - Eastside Controller	Stream: 3 PRC for Signalled Lanes (%)	13.5	Total Delay for Signalled Lanes (pcuHr)	7.03	Cycle Time (s)	76
C2 - Westside Controller	Stream: 1 PRC for Signalled Lanes (%)	-11.5	Total Delay for Signalled Lanes (pcuHr)	43.20	Cycle Time (s)	76
C2 - Westside Controller	Stream: 2 PRC for Signalled Lanes (%)	2.1	Total Delay for Signalled Lanes (pcuHr)	28.71	Cycle Time (s)	76
C2 - Westside Controller	Stream: 3 PRC for Signalled Lanes (%)	1.9	Total Delay for Signalled Lanes (pcuHr)	6.35	Cycle Time (s)	76
C2 - Westside Controller	Stream: 4 PRC for Signalled Lanes (%)	27.1	Total Delay for Signalled Lanes (pcuHr)	0.98	Cycle Time (s)	76
	PRC Over All Lanes (%)	-11.5	Total Delay Over All Lanes (pcuHr)	133.03		

**Scenario 4: '2031 With additional mez - PM ' (FG4: '2031 with additional mez - PM', Plan 1: 'Network Control Plan 1')**

**C1 - Eastside Controller  
Stage Sequence Diagram  
Stage Stream: 1**

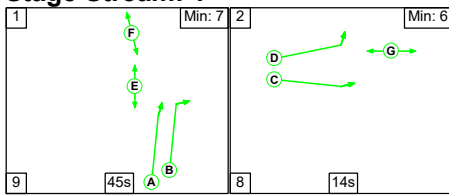

**Stage Stream: 2**

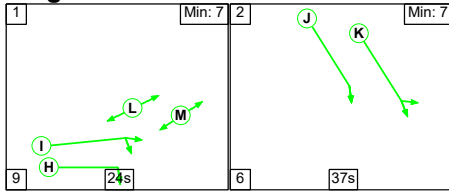

**Stage Stream: 3**

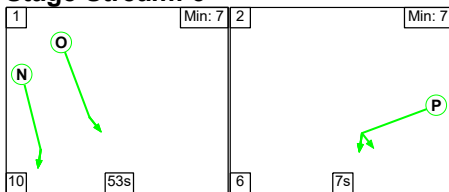

**Stage Timings  
Stage Stream: 1**

Stage	1	2
Duration	45	14
Change Point	4	58

**Stage Stream: 2**

Stage	1	2
Duration	24	37
Change Point	47	4

**Stage Stream: 3**

Stage	1	2
Duration	53	7
Change Point	58	45

# Signal Timings Diagram

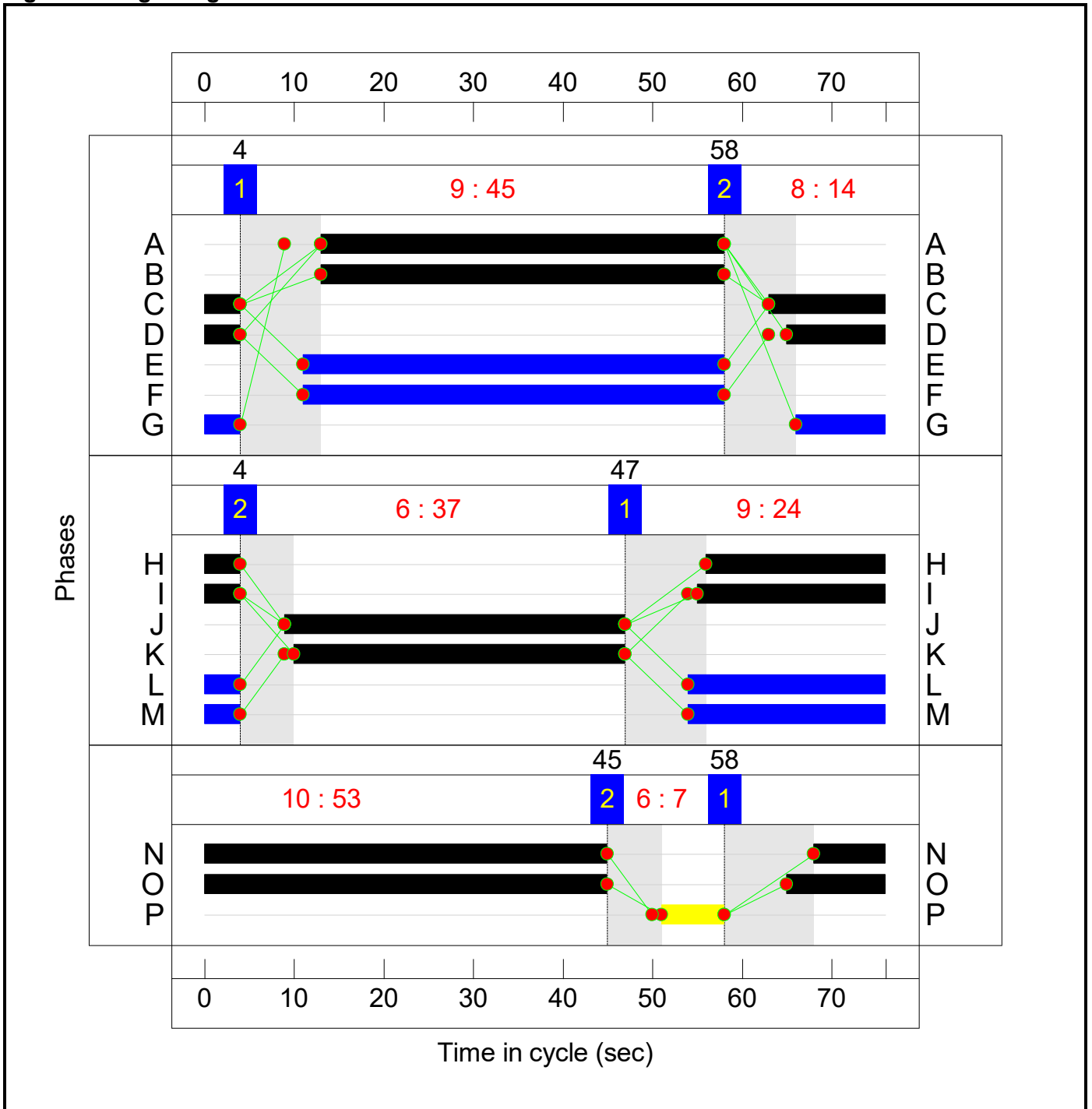

## C2 - Westside Controller Stage Sequence Diagram Stage Stream: 1

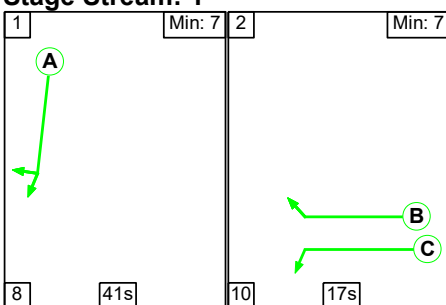

### Stage Stream: 2

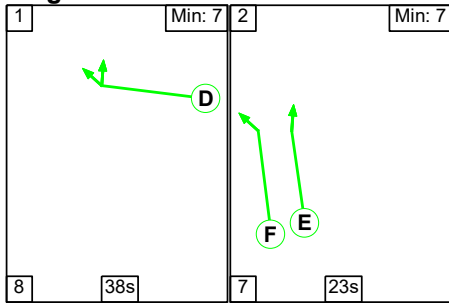

### Stage Stream: 3

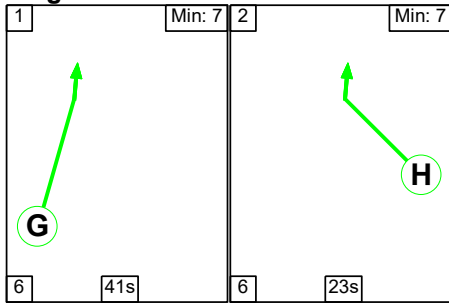

### Stage Stream: 4

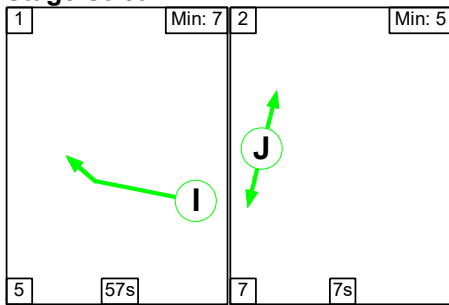

### Stage Timings

#### Stage Stream: 1

Stage	1	2
Duration	41	17
Change Point	24	73

#### Stage Stream: 2

Stage	1	2
Duration	38	23
Change Point	10	56

#### Stage Stream: 3

Stage	1	2
Duration	41	23
Change Point	33	4

#### Stage Stream: 4

Stage	1	2
Duration	57	7
Change Point	13	75

# Signal Timings Diagram

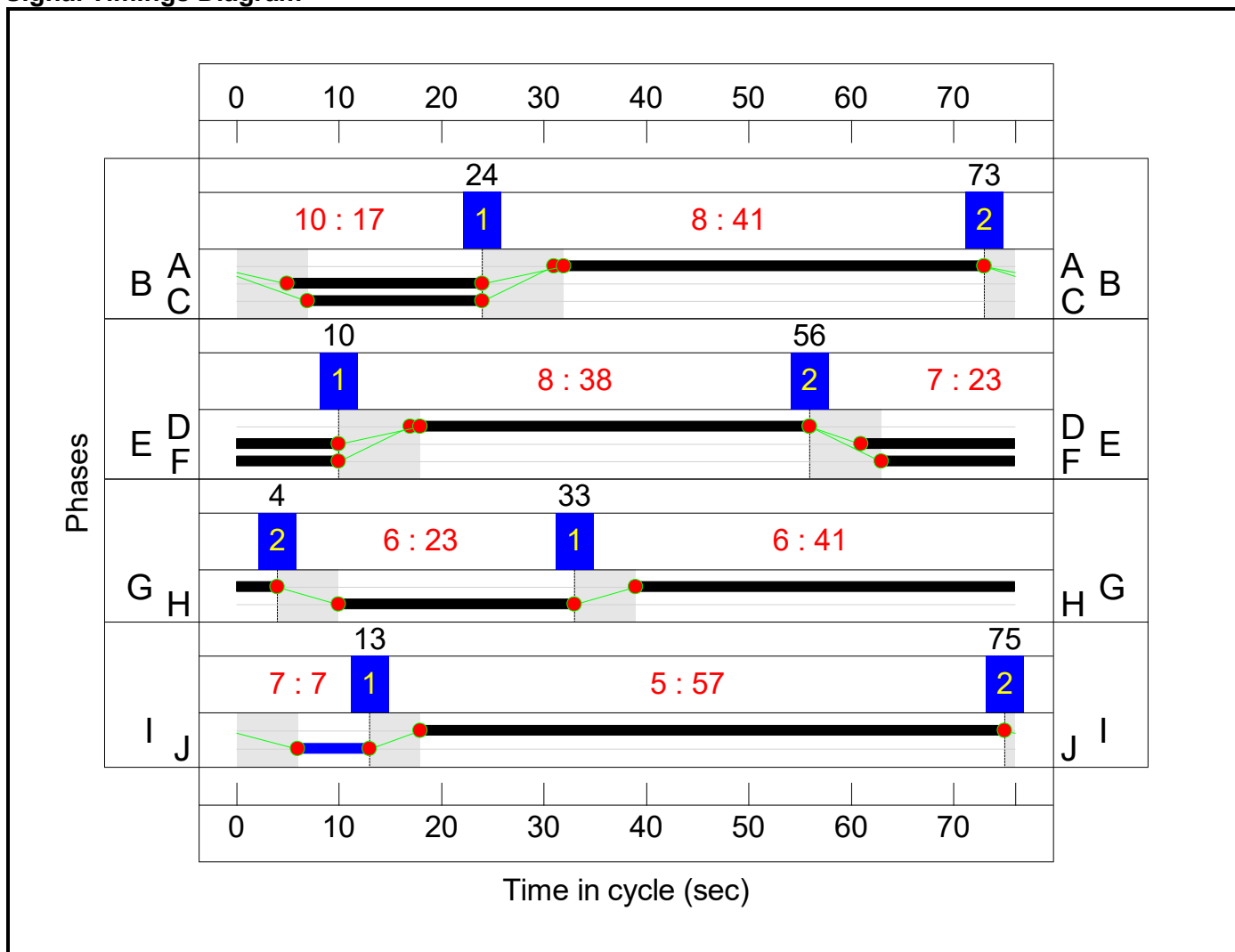

## Network Results

Item	Lane Description	Lane Type	Controller Stream	Position In Filtered Route	Full Phase	Arrow Phase	Num Greens	Total Green (s)	Arrow Green (s)	Demand Flow (pcu)	Sat Flow (pcu/Hr)	Capacity (pcu)	Deg Sat (%)
<b>Network: M1 Junction 15 impact with additional mezzanine</b>	-	-	<b>N/A</b>	-	-		-	-	-	-	-	-	<b>100.4%</b>
<b>M1 Junction 15</b>	-	-	<b>N/A</b>	-	-		-	-	-	-	-	-	<b>100.4%</b>
1/2+1/1	M1 Southbound Offslip Left	U	1:1	N/A	C1:D		1	15	-	607	2120:1980	446+417	70.4 : 70.3%
1/3+1/4	M1 Southbound Offslip Left Ahead	U	1:1	N/A	C1:D C1:C		1	15:17	-	1076	2120:4000	446+947	89.6 : 71.4%
3/1	Ahead	U	1:2	N/A	C1:I		1	25	-	137	1900	650	21.1%
3/2	Right	U	1:2	N/A	C1:I		1	25	-	222	1900	650	34.2%
3/3	Right	U	1:2	N/A	C1:H		1	24	-	274	1900	625	43.8%
3/4	Right	U	1:2	N/A	C1:H		1	24	-	353	1900	625	56.5%
4/2+4/1	A45 Southbound Left Ahead	U	1:2	N/A	C1:K		1	37	-	1073	2120:1980	1029+990	52.4 : 53.9%
4/3	A45 Southbound Ahead	U	1:2	N/A	C1:J		1	38	-	866	2120	1088	79.6%
4/4+4/5	A45 Southbound Ahead	U	1:2	N/A	C1:J		1	38	-	1749	2120:2120	851+1088	82.5 : 96.2%
6/1	M1 Northbound Circulatory Ahead	U	2:1	N/A	C2:A		1	41	-	1140	2120	1172	97.3%
6/2+6/3	M1 Northbound Circulatory Ahead Right	U	2:1	N/A	C2:A		1	41	-	1074	2120:2120	905+438	80.0 : 80.0%
6/4	M1 Northbound Circulatory Right	U	2:1	N/A	C2:A		1	41	-	1176	2120	1172	100.4%
8/1	Saxon Avenue Left Left2	U	1:3	N/A	C1:P		1	7	-	140	1884	198	70.6%
8/2	Saxon Avenue Left	U	1:3	N/A	C1:P		1	7	-	129	2105	222	58.2%
9/2+9/1	M1 Northbound Offslip Left Ahead	U	2:1	N/A	C2:B C2:C		1	19:17	-	716	2120:1980	558+239	89.8 : 89.8%

9/3+9/4	M1 Northbound Offslip Ahead	U	2:1	N/A	C2:B		1	19	-	1027	2120:2120	558+558	85.0 : 99.1%
11/1	Ahead	U	2:2	N/A	C2:D		1	38	-	652	1900	975	66.6%
11/2	Ahead Right	U	2:2	N/A	C2:D		1	38	-	874	1900	975	89.5%
12/1	Toucan Crossing Ahead	U	2:4	N/A	C2:I		1	57	-	1016	1995	1523	66.5%
12/2	Toucan Crossing Ahead	U	2:4	N/A	C2:I		1	57	-	1092	1995	1523	71.7%
13/2+13/1	A508 Northampton Rd Ahead	U	2:2	N/A	C2:F		1	23	-	729	1980:1980	552+550	66.1 : 66.1%
13/3	A508 Northampton Rd Ahead	U	2:2	N/A	C2:E		1	25	-	545	2120	725	75.1%
13/4+13/5	A508 Northampton Rd Ahead	U	2:2	N/A	C2:E		1	25	-	1231	2120:2120	725+725	81.8 : 88.0%
15/1	Ahead	U	1:1	N/A	C1:A		1	45	-	1171	2000	1211	96.7%
15/2	Ahead	U	1:1	N/A	C1:A		1	45	-	1089	2000	1211	89.9%
15/3+15/4	Ahead Right	U	1:1	N/A	C1:A C1:B		1	45	-	1191	2000:2000	1031+363	85.4 : 85.4%
16/1	Right	U	2:3	N/A	C2:H		1	23	-	501	2000	632	79.3%
16/2	Right	U	2:3	N/A	C2:H		1	23	-	474	2000	632	75.1%
16/3	Right	U	2:3	N/A	C2:H		1	23	-	553	2000	632	87.6%
17/1	Ahead	U	2:3	N/A	C2:G		1	41	-	670	2000	1105	60.6%
17/2	Ahead	U	2:3	N/A	C2:G		1	41	-	615	2000	1105	55.6%
17/3	Ahead	U	2:3	N/A	C2:G		1	41	-	638	2000	1105	57.7%
18/1	Ahead	U	1:3	N/A	C1:O		1	56	-	566	2000	1500	37.7%
18/2	Ahead	U	1:3	N/A	C1:O		1	56	-	641	2000	1500	42.7%
19/1	Ahead	U	1:3	N/A	C1:N		1	53	-	1140	2000	1421	80.2%
19/2	Ahead	U	1:3	N/A	C1:N		1	53	-	1055	2120	1506	70.0%
19/3	Ahead	U	1:3	N/A	C1:N		1	53	-	1047	2120	1506	69.5%

Item	Arriving (pcu)	Leaving (pcu)	Turners In Gaps (pcu)	Turners When Unopposed (pcu)	Turners In Intergreen (pcu)	Uniform Delay (pcuHr)	Rand + Oversat Delay (pcuHr)	Storage Area Uniform Delay (pcuHr)	Total Delay (pcuHr)	Av. Delay Per PCU (s/pcu)	Max. Back of Uniform Queue (pcu)	Rand + Oversat Queue (pcu)	Mean Max Queue (pcu)
<b>Network: M1 Junction 15 impact with additional mezzanine</b>	-	-	0	0	0	106.3	28.2	0.0	134.5	-	-	-	-
<b>M1 Junction 15</b>	-	-	0	0	0	106.3	28.2	0.0	134.5	-	-	-	-
1/2+1/1	607	607	-	-	-	4.7	1.2	-	5.9 (3.0+2.8)	34.8 (34.8:34.8)	6.1	1.2	7.3
1/3+1/4	1076	1076	-	-	-	8.2	1.7	-	9.9 (3.9+6.1)	33.2 (34.8:32.2)	8.1	1.7	9.8
3/1	137	137	-	-	-	0.3	0.0	-	0.3	8.1	0.9	0.0	0.9
3/2	222	222	-	-	-	1.5	0.0	-	1.5	24.3	4.7	0.0	4.7
3/3	274	274	-	-	-	0.5	0.0	-	0.5	6.8	1.2	0.0	1.2
3/4	353	353	-	-	-	0.4	0.0	-	0.4	4.5	0.6	0.0	0.6
4/2+4/1	1073	1073	-	-	-	3.8	0.6	-	4.4 (2.2+2.2)	14.8 (14.6:14.9)	7.7	0.6	8.3
4/3	866	866	-	-	-	3.7	1.9	-	5.6	23.2	14.9	1.9	16.8
4/4+4/5	1749	1749	-	-	-	7.8	4.4	-	12.2 (4.4+7.8)	25.1 (22.5:26.9)	21.2	4.4	25.6
6/1	1140	1140	-	-	-	6.8	0.0	-	6.8	21.4	24.1	0.0	24.1
6/2+6/3	1074	1074	-	-	-	6.6	0.0	-	6.6 (4.5+2.0)	22.0 (22.5:21.0)	22.0	0.0	22.0
6/4	1176	1172	-	-	-	4.8	2.2	-	7.0	21.5	25.0	2.2	27.2
8/1	140	140	-	-	-	1.3	1.2	-	2.4	62.6	2.8	1.2	4.0
8/2	129	129	-	-	-	1.2	0.7	-	1.8	51.6	2.6	0.7	3.3
9/2+9/1	716	716	-	-	-	5.2	4.0	-	9.3 (6.6+2.7)	46.5 (47.2:45.0)	10.2	4.0	14.2
9/3+9/4	1027	1027	-	-	-	7.8	5.2	-	13.0 (5.9+7.1)	45.5 (44.7:46.1)	11.5	5.2	16.7
11/1	649	649	-	-	-	4.2	0.0	-	4.2	23.3	9.3	0.0	9.3
11/2	873	873	-	-	-	4.5	0.0	-	4.5	18.6	9.6	0.0	9.6
12/1	1013	1013	-	-	-	0.4	0.0	-	0.4	1.3	2.2	0.0	2.2

12/2	1092	1092	-	-	-	0.3	0.0	-	0.3	1.1	2.1	0.0	2.1
13/2+13/1	729	729	-	-	-	4.4	1.0	-	5.4 (2.7+2.7)	26.6 (26.6:26.6)	6.4	1.0	7.4
13/3	545	545	-	-	-	3.4	1.5	-	4.8	32.0	10.1	1.5	11.6
13/4+13/5	1231	1231	-	-	-	7.9	2.7	-	10.7 (5.1+5.6)	31.2 (30.8:31.5)	12.6	2.7	15.3
15/1	1171	1171	-	-	-	3.4	0.0	-	3.4	10.5	24.6	0.0	24.6
15/2	1088	1088	-	-	-	2.7	0.0	-	2.7	9.0	18.3	0.0	18.3
15/3+15/4	1191	1191	-	-	-	1.4	0.0	-	1.4 (0.9+0.5)	4.2 (3.7:5.7)	16.5	0.0	16.5
16/1	501	501	-	-	-	0.1	0.0	-	0.1	0.5	0.6	0.0	0.6
16/2	474	474	-	-	-	0.1	0.0	-	0.1	0.5	0.5	0.0	0.5
16/3	553	553	-	-	-	0.1	0.0	-	0.1	0.6	0.6	0.0	0.6
17/1	670	670	-	-	-	1.7	0.0	-	1.7	9.2	4.8	0.0	4.8
17/2	614	614	-	-	-	2.0	0.0	-	2.0	11.6	4.6	0.0	4.6
17/3	638	638	-	-	-	2.4	0.0	-	2.4	13.6	5.1	0.0	5.1
18/1	566	566	-	-	-	0.3	0.0	-	0.3	1.9	3.4	0.0	3.4
18/2	641	641	-	-	-	0.4	0.0	-	0.4	2.0	3.2	0.0	3.2
19/1	1140	1140	-	-	-	0.8	0.0	-	0.8	2.4	3.1	0.0	3.1
19/2	1055	1055	-	-	-	0.4	0.0	-	0.4	1.4	2.0	0.0	2.0
19/3	1047	1047	-	-	-	0.9	0.0	-	0.9	3.2	3.3	0.0	3.3

C1 - Eastside Controller	Stream: 1 PRC for Signalled Lanes (%)	-7.5	Total Delay for Signalled Lanes (pcuHr)	23.33	Cycle Time (s)	76
C1 - Eastside Controller	Stream: 2 PRC for Signalled Lanes (%)	-6.9	Total Delay for Signalled Lanes (pcuHr)	24.95	Cycle Time (s)	76
C1 - Eastside Controller	Stream: 3 PRC for Signalled Lanes (%)	12.2	Total Delay for Signalled Lanes (pcuHr)	7.06	Cycle Time (s)	76
C2 - Westside Controller	Stream: 1 PRC for Signalled Lanes (%)	-11.5	Total Delay for Signalled Lanes (pcuHr)	42.56	Cycle Time (s)	76
C2 - Westside Controller	Stream: 2 PRC for Signalled Lanes (%)	0.6	Total Delay for Signalled Lanes (pcuHr)	29.61	Cycle Time (s)	76
C2 - Westside Controller	Stream: 3 PRC for Signalled Lanes (%)	2.8	Total Delay for Signalled Lanes (pcuHr)	6.32	Cycle Time (s)	76
C2 - Westside Controller	Stream: 4 PRC for Signalled Lanes (%)	25.5	Total Delay for Signalled Lanes (pcuHr)	0.69	Cycle Time (s)	76
	PRC Over All Lanes (%)	-11.5	Total Delay Over All Lanes (pcuHr)	134.52		

APPENDIX 2  
SUPPORTING LETTER



# **SUMMARY STATEMENT ON TRAFFIC AND TRANSPORT**

**NORTHAMPTON GATEWAY SRFI  
DCO AMENDMENT TO INCREASE MEZZANINE FLOOR SPACE**

## DOCUMENT CONTROL

project number: ADC3519			report reference: ADC3519-RP-B	
version	date	author	reviewer	comments
1	07/03/2025	Stuart Dunhill		draft issued for comment
2	28/03/2025	Stuart Dunhill	Mark Higgins	issued for submission

## CONTENTS

<b>1.0 INTRODUCTION .....</b>	<b>4</b>
<b>2.0 TRANSPORT ASSESSEMENT ADDENDUM .....</b>	<b>5</b>
<b>3.0 CONSULTATION WITH HIGHWAY AUTHORITIES .....</b>	<b>6</b>
National Highways .....	6
West Northampton Council .....	6

## APPENDICES

Appendix 1	Transport Assessment Addendum
Appendix 2	Supporting letter
Appendix 3	National Highways correspondence

## 1.0 INTRODUCTION

- 1.1 SEGRO Plc have commissioned ADC Infrastructure Ltd to provide transport advice with regards to an application to amend the Development Consent Order (DCO) for their Northampton Gateway Strategic Rail Freight Interchange (SRFI) development.
- 1.2 The amendment to the DCO is required in response to changes in market demand, as occupiers now require much greater volumes of mezzanine floor space than was previously the case. SEGRO are therefore seeking to amend the maximum amount of mezzanine floor space that is permitted under the DCO. This will safeguard the future build out of the SRFI site by ensuring that it can provide an appropriate mix of floor space and hence remain attractive to occupiers, whilst also maximising the floor space available in proximity to the rail terminal.
- 1.3 SEGRO are seeking to increase the amount of site wide mezzanine floor space that can be constructed at Northampton Gateway SRFI by 1.2 million sqft (111,480 sqm).
- 1.4 This summary statement, brings together the assessment work undertaken to consider the likely transport impacts of the proposed amendment to the DCO, including a summary of the position agreed with National Highways. It concludes that the proposed amendment will have no severe traffic impacts, and no additional significant environmental effects as compared to the scheme as consented.

## 2.0 TRANSPORT ASSESSEMENT ADDENDUM

2.1 A Transport Assessment (TA) Addendum (**Appendix 1**) has been prepared to assess the transport impact of the proposed amendment to increase the mezzanine floor space allowance at Northampton Gateway SRFI.

2.2 The key findings of the TA Addendum are:

- As part of the DCO for Northampton Gateway, a comprehensive package of highway mitigation measures is approved and consented. The highway improvement measures include a major upgrade to M1 Junction 15 and the A45, improvements to M1 Junction 15A, a bypass for the village of Roade, the implementation of environmental weight restrictions, improvements along the A508 as part of the A508 route upgrade, and financial contributions towards improvements to the A45 Queen Eleanor Interchange, and junctions along the A5076, and a Knock Lane and Blisworth Road maintenance and minor works fund.
- The construction of the offsite highway works commenced in 2021, and all the highway improvements are now complete and open to traffic.
- Walking and cycling strategies were developed in agreement with the highway authorities as part of the DCO. These are in the process of being put in place both within the development and off-site on the highway network, to provide enhanced connectivity from the SRFI site for pedestrians and cyclists to Collingtree, Northampton, and Roade.
- The internal and external footway/cycleway network provides significantly improved connections to the residential areas within the walking and cycling catchments and therefore, there are direct and safe walking and cycling routes to and from the SRFI.
- As part of the DCO, a public transport strategy was developed which includes the introduction of a new bus service specifically serving the SRFI site, as well as building on the existing local bus network and providing additional bus stops on the A508 to the north and south of the A508/site access roundabout.
- The proposal to increase the mezzanine floor space allowance at the SRFI site could increase the off-site vehicle trips by 105 two-way trips in the morning peak hour and 128 two-way vehicle trips in the evening peak hour. The assessment of the traffic impact has not considered the beneficial effect of the Travel Plan in reducing vehicle trips and therefore represents a robust position.
- The additional mezzanine floor space could generate up to 11 additional public transport trips, and five additional walking and cycling trips during a peak hour period.

2.3 The TA Addendum assessed the impact of the additional trips on the transport infrastructure. It concluded, subject to a minor improvement scheme at the SRFI site access roundabout on the A508, that the transport impacts arising from the increased mezzanine floor space would continue to be mitigated by the infrastructure improvements consented and delivered as part of the DCO, with residual impacts reduced to acceptable levels.

2.4 Accordingly, the proposed amendment will have no severe traffic impacts, and no additional significant environmental effects as compared to the scheme as consented.

### 3.0 CONSULTATION WITH HIGHWAY AUTHORITIES

- 3.1 The TA Addendum report was submitted on 19 September 2024 to National Highways, who are responsible for the Strategic Road Network, and West Northampton Council (WNC) who are the local highway authority.
- 3.2 As part of their review process, National Highways requested additional information. This was provided via a letter submission to National Highways dated 29 November 2024 (**Appendix 2**).

#### National Highways

- 3.3 Following their review of the TA Addendum and the additional information, National Highways confirmed in their email dated 15 January 2025 (**Appendix 3**) that they have no objection to the proposed amendment to the DCO to increase the mezzanine floor space at Northampton Gateway SRFI.

#### West Northampton Council

- 3.4 Confirmation of the National Highways position, along with the additional information submitted to National Highways, was also submitted to WNC on 28 January 2025. At the time of writing, WNC have not provided a formal response to the consultation submissions.

## APPENDIX 1

# TRANSPORT ASSESSMENT ADDENDUM



# **TRANSPORT ASSESSMENT ADDENDUM**

**NORTHAMPTON GATEWAY SRFI  
DCO AMENDMENT TO INCREASE MEZZANINE FLOOR SPACE**

## DOCUMENT CONTROL

project number: ADC3519			report reference: ADC3519-RP-A	
version	date	author(s)	reviewer	comments
1	22/05/2024	Stuart Dunhill and Mark Higgins	Mark Higgins	internal draft
2	23/05/2024	Stuart Dunhill and Mark Higgins	Mark Higgins	issued to client

## CONTENTS

<b>1.0</b>	<b>INTRODUCTION .....</b>	<b>4</b>
<b>2.0</b>	<b>CONSENTED DEVELOPMENT AND INFRASTRUCTURE .....</b>	<b>5</b>
	Site location.....	5
	Highway network .....	5
	Highway mitigation .....	6
	Walking and cycling infrastructure improvements.....	7
	Public Transport Strategy .....	11
	Summary .....	13
<b>3.0</b>	<b>TRIP GENERATION.....</b>	<b>15</b>
	Development Proposals.....	15
	Assessment of mezzanine floor space .....	15
	Vehicle trip generation .....	15
	Person trip generation .....	16
<b>4.0</b>	<b>TRIP DISTRIBUTION AND ASSIGNMENT .....</b>	<b>18</b>
	Vehicle trip distribution .....	18
	Vehicle trip assignment.....	18
<b>5.0</b>	<b>ASSESSMENT OF IMPACTS.....</b>	<b>19</b>
	Introduction.....	19
	Assessment flows .....	19
	A508 site access roundabout .....	19
	M1 Junction 15 .....	21
	Impact of additional person trips .....	22
<b>6.0</b>	<b>SUMMARY AND CONCLUSIONS .....</b>	<b>23</b>

## DIAGRAMS

Diagram 1	Trip distribution – AM peak hour
Diagram 2	Trip distribution – PM peak hour
Diagram 3	Additional mezzanine floor space development traffic – AM peak hour
Diagram 4	Additional mezzanine floor space development traffic – PM peak hour
Diagram 5	2031 background traffic flows with SRFI in place – AM peak hour
Diagram 6	2031 background traffic flows with SRFI in place – PM peak hour
Diagram 7	2031 total traffic flow – AM peak hour
Diagram 8	2031 total traffic flow – PM peak hour

## APPENDICES

Appendix A	DCO Parameters Plan
Appendix B	A508/site access LinSig assessment results
Appendix C	M1 Junction 15 LinSig assessment results

## 1.0 INTRODUCTION

- 1.1 SEGRO Plc have commissioned ADC Infrastructure Ltd to prepare a Transport Assessment (TA) Addendum to support an application to amend the Development Consent Order (DCO) for their Northampton Gateway Strategic Rail Freight Interchange (SRFI) development.
- 1.2 The amendment is required in response to changes in market demand, as occupiers now require much greater volumes of mezzanine floor space than was previously the case. SEGRO are therefore seeking to amend the maximum amount of mezzanine floor space that is permitted under the DCO. This will safeguard the future build out of the SRFI site by ensuring that it can provide an appropriate mix of floor space and hence remain attractive to occupiers.
- 1.3 In addition, West Northamptonshire Council are preparing their New Local Plan, which will guide development in the period up to 2041. Their Regulation 18 consultation draft document identifies a short fall of strategic warehousing space within West Northamptonshire during the plan period (this shortfall is notwithstanding the permitted development at the SRFI).
- 1.4 To meet this shortfall, draft Policy N8 identifies a single site for B8 warehousing located opposite Northampton Gateway SRFI. In identifying the most appropriate location for such development, paragraph 5.7.6 of the Regulation 18 consultation draft document notes the opportunity to provide a “...facility in close proximity to the motorway and adjacent to the rail freight terminal which is currently being constructed”. Paragraph 5.7.7 notes that “...connection to a strategic railfreight interchange will allow the industry to perform and progress in a sustainable manner.”
- 1.5 The location of the draft B8 allocation, adjacent to Northampton Gateway SRFI, demonstrates the importance of the SRFI site. This reinforces that opportunities to realise the development potential at the SRFI site should be maximised.
- 1.6 SEGRO are seeking to increase the amount of mezzanine floor space that can be delivered at Northampton Gateway SRFI by 1.2 million sqft (111,480 sqm).
- 1.7 This TA Addendum report has therefore been prepared to assess the implications of increasing the maximum mezzanine floor space permitted at Northampton Gateway SRFI by this amount. The DCO was supported by the approved TA<sup>1</sup>. This TA Addendum therefore revisits the approved TA work. It is structured as follows:
  - Section 2 provides a summary of development and highway infrastructure improvements consented under the Northampton Gateway SRFI DCO.
  - Section 3 considers the trip generation associated with the increased mezzanine floor space (based on the assumptions in the approved TA).
  - Section 4 assigns the additional development traffic to the highway network using the distributions from the approved TA.
  - Section 5 examines the impact of the additional development trips on the transport network.
- 1.8 Subject to an improvement scheme at the SRFI site access roundabout on the A508, Section 6 concludes that the transport impacts arising of the increased mezzanine floor space would continue to be mitigated by the consented highway infrastructure, and that the residual impacts are reduced to acceptable levels. Accordingly, there should be no objection to the proposed DCO amendment.

---

<sup>1</sup> Northampton Gateway Strategic Rail Freight Interchange Transport Assessment, report reference ADC1475 TA ver 4, ADC Infrastructure, 8 May 2018. ([planninginspectorate.gov.uk](http://planninginspectorate.gov.uk))

## 2.0 CONSENTED DEVELOPMENT AND INFRASTRUCTURE

- 2.1 The DCO for Northampton Gateway SRFI was granted in October 2019. It consents for the following development at the Northampton Gateway SRFI site:
- an intermodal freight terminal including container and HGV parking, rail sidings to serve individual warehouses, and the provision of an aggregates facility as part of the intermodal freight terminal, with the capability to also provide a rapid rail freight facility;
  - up to 468,000 sqm of warehousing and ancillary buildings, with additional floorspace provided in the form of mezzanines;
  - a secure, dedicated, HGV parking area of approximately 120 spaces including driver welfare facilities to meet the needs of HGVs visiting the site or intermodal terminal;
  - new road infrastructure and works to the existing road network, including the provision of a new access and associated works to the A508, a new bypass to the village of Roade, improvements to Junction 15 and to J15A of the M1 motorway, the A45, and other highway improvements at junctions on the local highway network and related traffic management measures;
  - strategic landscaping and tree planting, including diverted public rights of way;
  - earthworks and demolition of existing structures on the SRFI site.
- 2.2 The maximum mezzanine floor space permitted under the DCO is given on the DCO Parameters Plan (**Appendix A**). This permits up to 155,000 sqm of mezzanine floor space across the site.

### Site location

- 2.3 The Northampton Gateway SRFI site is located within the administrative area of West Northamptonshire Council. It is located to the west of M1 Junction 15, approximately 6km from Northampton Town Centre. A general site location plan is shown at **Figure 1**. It is bounded to the northeast by the M1 motorway, to the southeast by the A508, to the north by Collingtree Road, and by the Northampton Loop line of the West Coast Main Line (WCML) railway to the west.
- 2.4 West Northamptonshire Council is the local highway authority (formally Northamptonshire County Council), and National Highways has responsibility for the Strategic Road Network (SRN), which near the site comprises the M1 motorway, M1 Junctions 15 and 15A, the A45, and the A43.

### Highway network

- 2.5 The highway network adjacent to the site is shown in **Figure 1**, which is described in detail in the approved TA for the DCO.
- 2.6 The Northampton Gateway SRFI site access is located on the A508. The A508 runs from its junction with the M1 and the A45 (M1 Junction 15) in the north, to the A5 at the A5/ A508/ A422/ Towcester Road roundabout in Old Stratford to the south.
- 2.7 The M1 motorway is a strategic route for local, regional, and international traffic and plays an important role as a direct motorway between the north and south and a major route connecting some of the largest conurbations in the UK. The A45 provides a route around the eastern edge of Northampton and connects with the A14 to the north.
- 2.8 Hence in terms of the SRN, the Northampton Gateway SRFI site provides excellent connection opportunities with the rest of the UK, via the M1, A45, A14 and A43.



Figure 1: general site location

### Highway mitigation

2.9 As part of the DCO for the Northampton Gateway SRFI, a comprehensive package of highway mitigation measures was approved and consented. The full package of works comprises the following:

- A new roundabout on the A508 Northampton Road to serve as the access to the development, configured to require all departing HGVs to travel north to M1 Junction 15;
- Dualling of the A508 between the new site access roundabout and M1 Junction 15;
- Significant enlargement and reconfiguration of M1 Junction 15;
- Widening of the A45 to the north of M1 Junction 15 and the signalisation of the Watling Lane junction;
- Alteration of M1 Junction 15A to provide an additional lane and signalisation on the A43 northbound approach, signal control and additional flared lane on the A43 eastbound approach, an additional lane on the A5123 southbound approach and circulatory carriageway widening;
- Construction of a new bypass west of Roade between the A508 Northampton Road to the north of Roade and the A508 Stratford Road to the south of Roade, including a four-arm roundabout connecting the Bypass to Blisworth Road;
- 7.5T environmental weight restrictions (with access permitted for loading):
  - throughout Roade;
  - along Knock Lane/Blisworth Road between Roade Bypass and Stoke Road;

- along Blisworth Road (Courteenhall Road) between the A508 and High Street, including parts of Blisworth;
- along the unnamed road between the A508 and Quinton;
- throughout Stoke Bruerne and Shutlanger; and
- Wootton & East Hunsbury, to the west of the A45, east of Towcester Road and south of the A5076.
- Improvements at key locations along the A508 as part of an ‘A508 route upgrade’; comprising:
  - Blisworth Road (Courteenhall) junction improvement;
  - C26 Rookery Lane/Ashton Road junction improvement;
  - C85 Pury Road junction improvement;
  - C27 Stoke Road/Knock Lane junction improvement and additional widening to Knock Lane/Blisworth Road (although not on the A508, this is required because of changing traffic volumes on the A508); and
  - Provision of a pedestrian crossing at a bus stop and ghost island in Grafton Regis.
- A financial contribution provided for:
  - improvement schemes at the A45 Queen Eleanor Interchange and at junctions along the A5076, extending between the A45 and A5123; and
  - a Knock Lane and Blisworth Road maintenance and minor works fund, to be used in the event that the increased use of the roads should advance the need for maintenance or other remedial works.

2.10 The approved highway mitigation measures are necessary to provide satisfactory access to the Northampton Gateway SRFI as a whole and to mitigate the traffic impacts of the development. It was demonstrated via the DCO that the highway mitigation works also release existing constraints on the A508, M1 and A45 corridors, allowing the highway network to function in a safer and more efficient manner, and allowing the benefits of the proximity of the SRFI site to M1 Junction 15 to be fully realised.

2.11 The phased construction of the offsite highway works described above also commenced in 2021 and are now largely complete. The new site access roundabout on the A508 Northampton Road, dualling of the A508 between the new site access roundabout and M1 Junction 15, the significant enlargement and reconfiguration of M1 Junction 15, the Roade Bypass, and the upgrade of M1 Junction 15A are all open to traffic. Except for works on the A508 associated with the access to the Courteenhall Estate, all the A508 route upgrade highway works are also complete and open to traffic.

### **Walking and cycling infrastructure improvements**

2.12 The conditions for pedestrians and cyclists prior to the development of the SRFI are described in detail in the Walking, Cycling & Horse-Riding Assessment review (WCHAR) Report that is part of the Transport Assessment for the Northampton Gateway SRFI development.

2.13 It was concluded that there are good opportunities for pedestrian and cycle travel associated with the SRFI. However, the WCHAR found that the M1 could provide a barrier to pedestrian and cycle travel to/from the northeast of the site, where the residential areas within walking distance are located.

2.14 Therefore, as part of the DCO for the wider site, walking and cycling strategies were developed in agreement with the highway authorities, both within the development and off-site on the local highway network, to provide further connectivity from the SRFI site to Collingtree, Northampton, and Roade. These improvements have now been implemented or are under construction.

- 2.15 The SRFI access roundabout is now constructed and provides a puffin crossing on the A508 northern arm of the roundabout to facilitate access to the new southbound bus stop. A Toucan crossing is provided on the segregated left-turn exit lane of the SRFI site access arm, with uncontrolled crossings provided on the right turn exit and entry arm to the SRFI site. A shared footway/cycleway runs around the roundabout and connects into the site access. The footway/cycleway provides a connection to the new northbound bus stop that has been provided to the south of the site access roundabout on the A508.
- 2.16 This new footway/cycleway extends alongside the west side of the A508, linking the site access roundabout with M1 Junction 15 to the north. The footway/cycleway also extends south, providing a connection to the footway/cycleway facility that is provided alongside the western side of the A508 Road Bypass. When taken together, the new facilities provide a shared use footway/cycleway connecting Road with the site and the existing Northampton footway/cycleway network to the north.
- 2.17 At the southwest corner of M1 Junction 15, a direct pedestrian and cycle connection to Northampton Gateway SRFI is provided. This pedestrian and cycle access links to the internal off-street footway/cycleway network and connects to the estate road at the first internal roundabout. A further pedestrian and cycle access (and emergency access) to the SRFI is provided approximately halfway between the site access roundabout and M1 Junction 15, providing further direct access.
- 2.18 Within the Northampton Gateway SRFI site, a shared footway/cycleway is provided between the A508/site access roundabout and the first internal roundabout, with shared footway/cycleway facilities provided on both sides of the main estate road. In due course, pending the development of Zones A1b/c of the SRFI site, a further shared footway/cycleway will be provided linking directly from the estate road to the Collingtree bridge over the M1.
- 2.19 Guidelines for Providing Journeys on Foot<sup>2</sup> describes acceptable walking distances for pedestrians without mobility impairment. They suggest that for commuters up to 500m is the desirable walking distance, up to 1km is an acceptable walking distance, and up to 2km is the preferred maximum walking distance. As shown in **Figure 2**, a 2km catchment from the site includes Collingtree, Milton Malsor, and Grange Park.
- 2.20 The South Northampton Sustainable Urban Extension (SUE), which is a committed development of some 1,000 dwellings, is located just outside the preferred maximum walking distance. However, with the new non-motorised strategies that the DCO consents, the SUE development will be within an acceptable walking distance.

---

<sup>2</sup> Guidelines for Providing for Journeys on Foot, Institution of Highways and Transportation, 2000

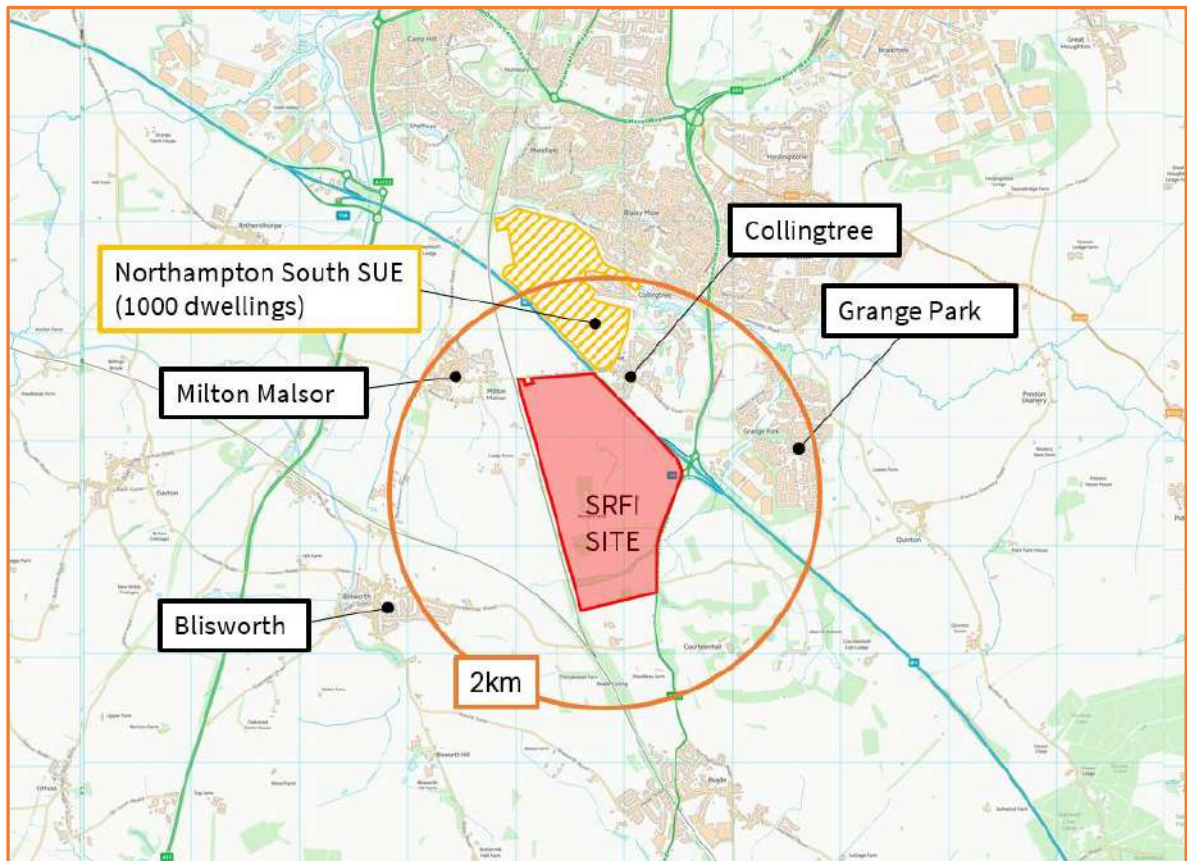

Figure 2: pedestrian catchment area

- 2.21 Two public footpaths previously ran through the wider Northampton Gateway SRFI development site (KX13 and KX17). These public rights of way have been diverted in accordance with the DCO consent, providing new routes around the SRFI site.
- 2.22 Cyclists are typically prepared to cycle up to 5km for non-leisure journeys, such as those to work. However, statistics published in the National Travel Survey showed that commuting cyclists typically cycled 23 minutes from their home to their place of work. Typical guidance also suggests an average cycle speed of 12mph. Combining these two factors, a cyclist travelling at 12mph for 23 minutes will cover a distance of 7.4km. **Figure 3** therefore shows a 5km and 7.4km cycle catchment from the centre of the site.
- 2.23 A 5km cycle catchment includes a large portion of southern Northampton and the surrounding villages, including Road to the south. Northampton Railway Station falls just outside the 5km catchment but would still be within an acceptable cycle distance for regular commuters. A 7.4km cycle catchment also includes Northampton Town Centre.

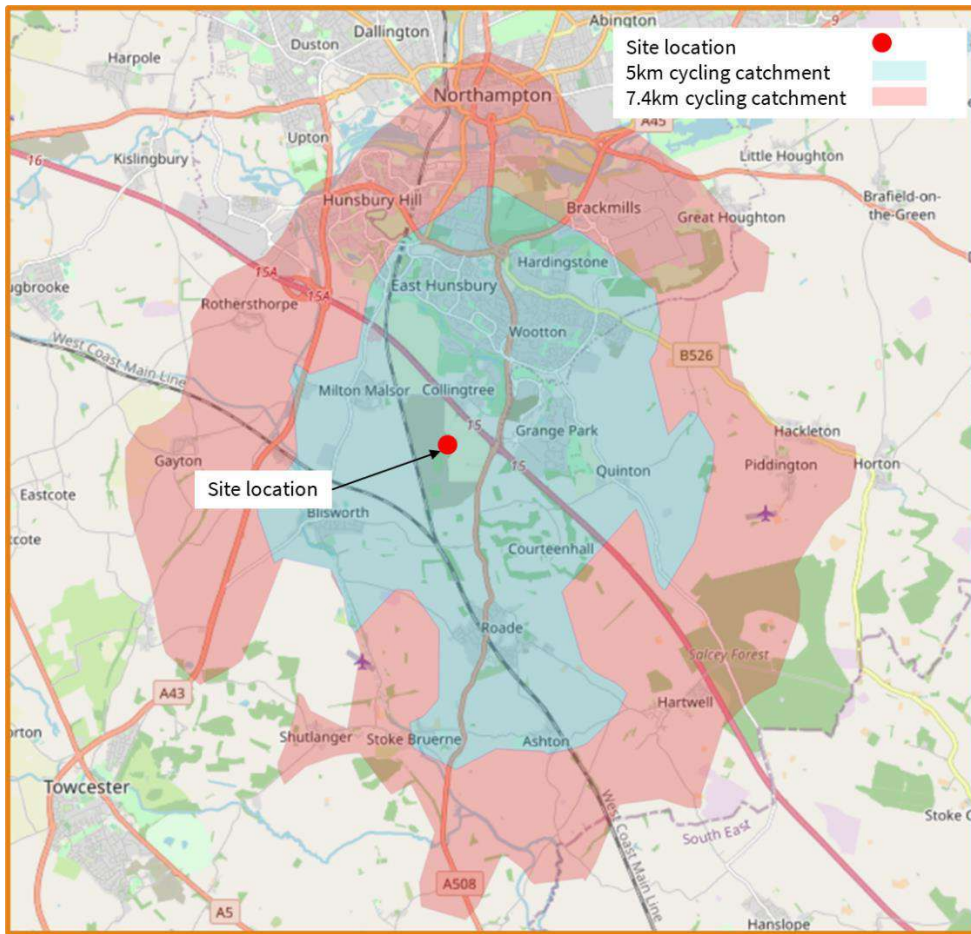

Figure 3: cycle catchment area

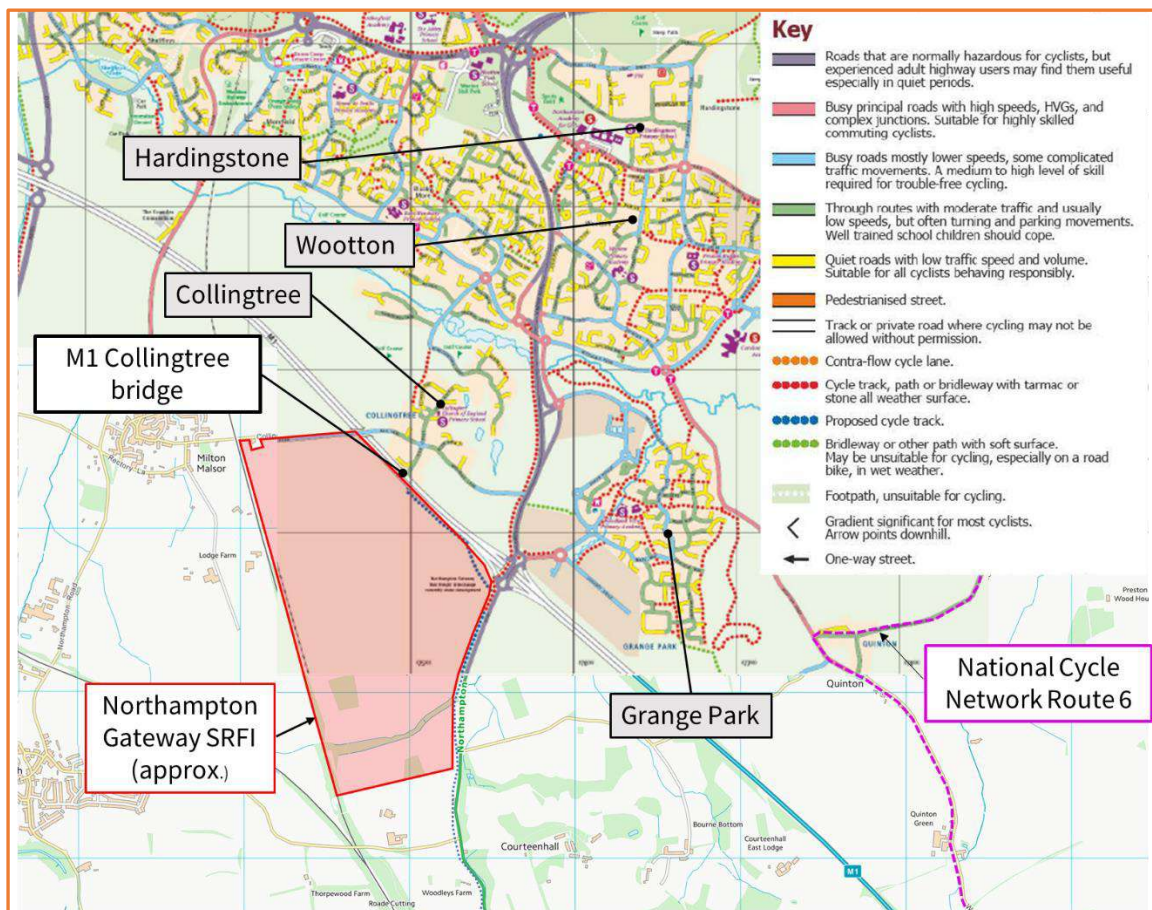

Figure 4: cycle routes (composite based on extract of Northampton cycle map)

- 2.24 As shown in **Figure 4**, there are a network of cycle facilities and Advisory Routes within East Hunsbury that provide onwards connection to Northampton and are accessible via Collingtree. There is also a network of cycle facilities within Grange Park, providing onwards links to the Wootton and Hardingstone residential area. **Figure 4** also shows some of the cycle improvements consented as part of the DCO (proposed cycle track on the NCC map).
- 2.25 National Cycle Network Route 6 is located to the east of the site as shown on **Figures 4 and 5**. The route encompasses Quinton, Hardingstone (including the Hardingstone SUE), and Brackmills Industrial Estate, en-route to Northampton Town Centre.

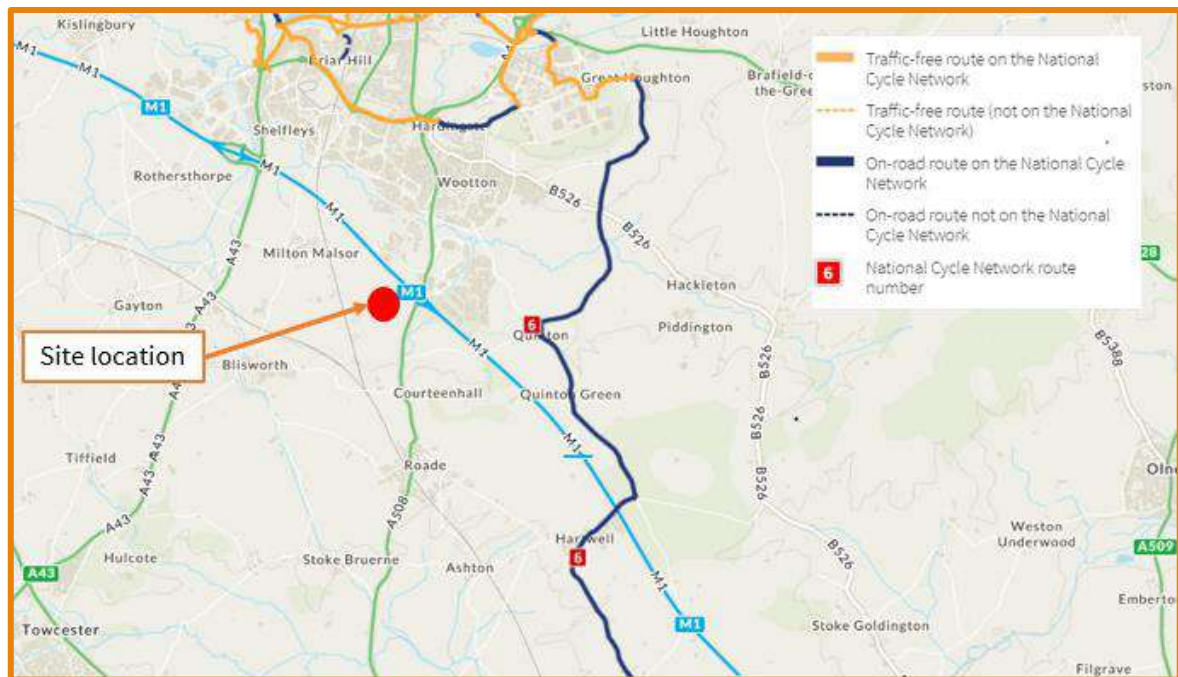

Figure 5: extract of national cycle map

- 2.26 The improvement works at M1 Junction 15 provide traffic signal-controlled facilities at each crossing location. A new shared use pedestrian and cycle link has been provided from M1 Junction 15 along the A45, linking with the Watering Lane to the north.
- 2.27 The consented improvements at the Watering Lane junction with the A45 have been completed, with Toucan crossings provided on the Watering Lane arm to assist pedestrians and cyclists accessing the shared footway/cycleway facility on the northern side of Watering Lane. In addition, an uncontrolled crossing is provided between the hotel and the footway on the northern side of Watering Lane, west of the A45 junction.
- 2.28 The internal and external footway/cycleway network therefore provides significantly improved connections to the residential areas within the walking and cycling catchments with appropriate crossing facilities provided. Therefore, there are direct and safe walking and cycling routes to and from the SRFI.

### Public Transport Strategy

- 2.29 The existing bus services near to the site are shown in **Figure 6**, with the 33, the 33A and the X6 currently passing immediately in front of the site on the A508. All services provide a route from Northampton to Milton Keynes.



Figure 6: bus routes

- 2.30 The number 33 bus provides two services in the morning and two in the evening. The X6 runs from 06:31 (at the bus stop in Road) with seven services between 06:31 to 10:24 and then roughly every half an hour until 20:12. All services provide a connection to Northampton bus interchange.
- 2.31 As part of the DCO for the Northampton Gateway SRFI development, a public transport strategy was developed which includes the introduction of a new bus service specifically serving the SRFI site, as well as building on the existing local bus network and providing additional bus stops on the A508 to the north and south of the A508/SRFI site access roundabout, giving access to the 33/33A and the X6 services. The strategy is explained in detail in the TA that accompanied the DCO and is summarised below.
- 2.32 The new bus service to/from Northampton Gateway SRFI will be introduced in four phases. The initial phase will involve the introduction of the service at key shift times, most likely around 0600-1400-2200 hours, but will be flexible to end users' requirements. A requirement of the DCO is that prior to commencement of the construction of any warehousing, the Sustainable Transport Working Group will be established, who will have oversight of the Framework Travel Plan and Public Transport Strategy.
- 2.33 Once the first phase of the bus service has been established, the Sustainable Transport Working Group will monitor the opportunity of continuing the bus service between peaks, to develop a

regular bus service for users throughout the day, and as demand grows, to increase the service frequency from hourly to half hourly.

- 2.34 The proposed bus service will offer direct access from the SRFI site to Northampton Town Centre. The most direct route would see the service following the A508/A45/A508 to The Drapery (or North Gate Bus Station). As well as serving the town centre, the service could also serve stops on London Road (A508). On the SRFI site, the service would use the SRFI access on the A508, enter the site, serving the bus stops on the estate road and use the turning circle (roundabout) at the westerly end of the site.
- 2.35 The nearest railway station is Northampton which is approximately 6km to the north of the proposed development and on the WCML loop from Birmingham to London. The station can be accessed via cycle or a bus to the North Gate Bus Station and the railway station is within a 10 minutes' walk of the bus station. There is a traffic free/lightly trafficked cycle route to the station. The railway station is served by a good service to and from Rugby, at least every 20 minutes at peak times, together with direct trains to London and Birmingham. The opportunity will therefore exist for staff to travel by train to Northampton and complete their journey either by cycle or via the connecting bus services.

### Summary

- 2.36 The principle that Northampton Gateway SRFI is a suitable location for B8 employment use was established as part of the DCO for the scheme. This is reinforced by West Northamptonshire Council's New Local Plan Regulation 18 document, which puts forward the land adjacent to Northampton Gateway SRFI as suitable for B8 development.
- 2.37 Northampton Gateway SRFI is located adjacent to M1 Junction 15 and hence provides excellent connection opportunities with the whole of the UK, via the M1, A45, A14, A43 and A5.
- 2.38 As part of the DCO for Northampton Gateway, a comprehensive package of highway mitigation measures is approved and consented. The highway improvement measures include a major upgrade to M1 Junction 15 and the A45, improvements to M1 Junction 15A, a bypass for the village of Roade, the implementation of environmental weight restrictions, improvements along the A508 as part of the A508 route upgrade, and financial contributions towards improvements to the A45 Queen Eleanor Interchange, and junctions along the A5076, and a Knock Lane and Blisworth Road maintenance and minor works fund.
- 2.39 The construction of the offsite highway works commenced in 2021 and are now largely complete. The new site access roundabout on the A508 Northampton Road, dualling of the A508 between the new site access roundabout and M1 Junction 15, the significant enlargement and reconfiguration of M1 Junction 15, the Roade Bypass, and the upgrade of M1 Junction 15A are all open to traffic. Except for works on the A508 associated with the access to the Courteenhall Estate, all the A508 route upgrade highway works are also complete and open to traffic.
- 2.40 Walking and cycling strategies were developed in agreement with the highway authorities as part of the DCO. These are in the process of being put in place both within the development and off-site on the highway network, to provide enhanced connectivity from the SRFI site for pedestrians and cyclists to Collingtree, Northampton, and Roade. The measures are summarised as follows:
- A comprehensive network of both on street and off-street shared footway/cycleways throughout the SRFI site with appropriate crossing points provided.

- New footway/cycleway facilities alongside the A508, linking the site access roundabout with the Roade bypass to the south and M1 Junction 15 to the north, with signal controlled crossing facilities at the site access roundabout providing access to new bus stops.
- A comprehensive upgrade of walking and cycling facilities at M1 Junction 15 including Toucan crossings at all crossing points.
- New footway/cycleway between M1 Junction 15 and the junction with Watering Lane, with Toucan crossing to connect to the existing facilities to the north.
- Public footpaths KX17 and KX13 that cross the SRFI site have been diverted and extended to form a loop within the landscape bunding.
- A cycle track (for use by pedestrians and cyclists) connecting the development to Collingtree, and the wider Northampton area, via the existing bridge over the M1.

2.41 The internal and external footway/cycleway network provides significantly improved connections to the residential areas within the walking and cycling catchments and therefore, there are direct and safe walking and cycling routes to and from the SRFI.

2.42 As part of the DCO, a public transport strategy was developed which includes the introduction of a new bus service specifically serving the SRFI site, as well as building on the existing local bus network and providing additional bus stops on the A508 to the north and south of the A508/site access roundabout.

### 3.0 TRIP GENERATION

#### Development Proposals

- 3.1 The amendment to the DCO is required in response to changes in market demand, as occupiers now require much greater volumes of mezzanine floor space than was previously the case. SEGRO are therefore seeking to amend the maximum amount of mezzanine floor space that is permitted under the DCO. This will safeguard the future build out of the SRFI site by ensuring that it can provide an appropriate mix of floor space and hence remain attractive to occupiers.
- 3.2 SEGRO are seeking to increase the amount of site-wide mezzanine floor space that can be delivered at Northampton Gateway SRFI by 1.2 million sqft (111,480 sqm).

#### Assessment of mezzanine floor space

- 3.3 Mezzanine floor space does not generate trips on a pro-rata basis with conventional floor space and it is appropriate that the mezzanine floor space is not treated in a conventional way in terms of trip generation.
- 3.4 This is because mezzanines are typically introduced to enhance access to existing high-level storage areas, or to house automated operations. In each case, these functions do not result in a pro-rata increase in staff numbers compared to conventional floor space. The former, because, in the absence of mezzanine levels, high-level storage is typically used to access the warehouse space. The latter because automated operations are less staff intensive.
- 3.5 The employment densities for B8 uses given in the Homes and Communities Agency's (HCA) employment density guide (3rd edition 2015) are based on gross external area (GEA) and not GFA<sup>3</sup>. The GEA of a unit is not influenced by mezzanine floor space and therefore this supports the above position that mezzanine levels do not result in a pro-rata increase in staff.
- 3.6 Importantly, HGV generations are typically related to the number of loading bays, which are located on the ground floor and hence do not increase when mezzanine levels are introduced. Therefore, whilst the mezzanine levels may include automated operations which could improve efficiency and HGV throughput, there would not be a pro-rata increase in HGV numbers as these would be restricted by the number of loading bays.
- 3.7 The principle that mezzanine floor space does not generate trips on a pro-rata basis with conventional floor space was accepted as part of the DCO for Northampton Gateway SRFI. The position agreed in the TA that supported the DCO was to account for mezzanine floor space as generating trips at 50% of the rate of conventional floor space.
- 3.8 This TA Addendum therefore adopts the 50% trip generation rate for mezzanine floor space that was agreed in the TA. This ensures consistency with that work.

#### Vehicle trip generation

- 3.9 The vehicle trip rates for B8 warehousing (not accounting for the Travel Plan) have been extracted from the Northampton Gateway TA and are given below.

---

<sup>3</sup> Employment Density Guide 3<sup>rd</sup> edition: November 2015. Homes and Communities Agency; page 29.

	DCO vehicle trip rates per 100 sqm B8 use								
	light vehicles			heavy vehicles			total vehicles		
	Arrive	Depart	Two-way	Arrive	Depart	Two-way	Arrive	Depart	Two-way
AM	0.128	0.014	0.142	0.024	0.022	0.046	0.152	0.036	0.188
PM	0.042	0.147	0.190	0.021	0.019	0.040	0.063	0.166	0.230
Daily	1.119	1.101	2.220	0.326	0.326	0.652	1.445	1.427	2.872

3.10 The proposed 111,480 sqm of additional mezzanine floor space is assessed as generating the following vehicle trips, based on the agreed vehicle trips rates, and applying the 50% mezzanine factor.

	traffic generation based on DCO B8 vehicle trip rates and 50% mezzanine factor (not accounting for Travel Plan and excluding reductions due to rail interaction)								
	light vehicles			heavy vehicles			total vehicles		
	arrive	depart	two-way	arrive	depart	two-way	arrive	depart	two-way
AM	71	8	79	13	12	26	85	20	105
PM	23	82	105	12	11	22	35	93	128
Daily	624	614	1237	182	182	363	805	795	1601

3.11 No account of the potential interaction with the rail terminal has been made, and hence this further represents a robust position.

3.12 Northampton Gateway SRFI was assessed as generating 1,044 two-way vehicle trips in the morning peak hour, 1,303 two-way vehicle trips in the evening peak hour, and 16,531 vehicle trips over a 24-hour period.

3.13 The proposal to increase the mezzanine floor space allowance at the SRFI site could increase the off-site vehicle trips by 105 two-way trips in the morning peak hour, 128 two-way vehicle trips in the evening peak hour, and 1,601 vehicle trips over a 24-hour period. This equates to a 10% increase in off-site traffic.

### Person trip generation

3.14 The Public Transport Strategy, car share, and the pedestrian and cyclist strategy for the Northampton Gateway SRFI site were designed to positively influence the modal share to limit traffic generation. The Framework Travel Plan<sup>4</sup> sets the following modal share targets for the Northampton Gateway SRFI site. The occupiers are required to develop their own detailed Travel Plan in accordance with the requirements of the Framework Travel Plan.

mode	year 1	year 5
single occupancy vehicle	92%	74%
car share	5%	12%
public transport	3%	10%
walking and cycling	0%	4%

3.15 The Framework Travel Plan has the following modal share targets:

- Achieve a 20% reduction in single occupancy car journeys within 5 years
- 12% of employees to car share within 5 years
- 10 of employees trips to be made by bus within 5 years
- 3% of employee trips to be made by bike and 1% by foot within 5 years.

<sup>4</sup> Northampton Gateway Strategic Rail Freight Interchange, Framework Travel Plan, Version 2.7 Feb 2018, ITP ([planninginspectorate.gov.uk](http://planninginspectorate.gov.uk))

3.16 Based on the above modal share targets, and the assessment of the light vehicle trips given at paragraph 3.10 (as HGV trips would not undergo a modal shift, as their primary purpose is the transportation of their cargo), the tables below summarises the forecast daily, morning and evening peak hour, person trips that could be associated with the proposed additional mezzanine floor space at Northampton Gateway SRFI upon opening, and after 5 years.

summary of daily person trips by mode (based on agreed DCO trip rates)				
mode	year 1		year 5 target	
	arrive	depart	arrive	depart
car driver	624	614	502	494
hgv driver	182	182	182	182
car share	34	33	81	80
public transport	20	20	68	67
walking/cycling	0	0	27	27
<b>total</b>	<b>860</b>	<b>849</b>	<b>860</b>	<b>849</b>

summary of AM peak hour person trips by mode (based on agreed DCO trip rates)				
mode	year 1		year 5 target	
	arrive	depart	arrive	depart
car driver	71	8	57	6
hgv driver	13	12	13	12
car share	4	0	9	1
public transport	2	0	8	1
walking/cycling	0	0	3	0
<b>total</b>	<b>91</b>	<b>21</b>	<b>91</b>	<b>21</b>

summary of PM peak hour person trips by mode (based on agreed DCO trip rates)				
mode	year 1		year 5 target	
	arrive	depart	arrive	depart
car driver	23	82	19	66
hgv driver	12	11	12	11
car share	1	4	3	11
public transport	1	3	3	9
walking/cycling	0	0	1	4
<b>total</b>	<b>37</b>	<b>100</b>	<b>37</b>	<b>100</b>

3.17 The Travel Plan would reduce the overall traffic generation associated with Northampton Gateway SRFI. However, no Travel Plan deduction was applied to the traffic generations assessed in the approved TA. Accordingly, the highway infrastructure implemented by Northampton Gateway is designed to accommodate the pre-Travel Plan traffic generations.

3.18 To consider a robust position, and provide consistency with the TA, the following sections of this TA Addendum therefore consider the impact of the additional highway trips generated by the mezzanine floor space on the highway infrastructure without considering the impact of the Travel Plan.

## 4.0 TRIP DISTRIBUTION AND ASSIGNMENT

### Vehicle trip distribution

4.1 The vehicle trip distributions established for the light vehicle trips and HGV trips for the Northampton Gateway SRFI scheme have been extracted from the approved TA. These are summarised at **Diagrams 1 and 2**.

### Vehicle trip assignment

4.2 The vehicle trip generations for the additional mezzanine floor space given at paragraph 3.10 have been assigned to the highway network in accordance with the above distributions.

4.3 The resultant traffic flow assignment for the additional mezzanine floor space is shown at **Diagrams 3 and 4** for the morning and evening peak hours and is summarised in the table below.

traffic due to increased mezzanine floor space - AM peak hour total vehicles					
	A45	M1 south	A508 (btw site and M1 J15)	M1 north	A508 south of site
arrival	32	22	73	18	12
departure	9	5	18	5	2
<b>two-way</b>	<b>41</b>	<b>27</b>	<b>91</b>	<b>23</b>	<b>14</b>
traffic due to increased mezzanine floor space - PM peak hour total vehicles					
	A45	M1 south	A508 (btw site and M1 J15)	M1 north	A508 south of site
arrival	14	6	30	10	5
departure	46	19	81	16	12
<b>two-way</b>	<b>60</b>	<b>25</b>	<b>111</b>	<b>26</b>	<b>17</b>

## 5.0 ASSESSMENT OF IMPACTS

### Introduction

- 5.1 As shown in Section 4, the traffic associated with the additional mezzanine floor space would quickly disburse the highway network, with less than 30 two-way vehicle trips on the A508 to the south of the site, and only modest increases in traffic on the M1 and A45 approaches to M1 Junction 15.
- 5.2 Therefore, the study area for this TA Addendum has been limited to the A508 site access roundabout and M1 Junction 15.

### Assessment flows

- 5.3 The 2031 morning and evening peak hour future traffic flows with the SRFI and highway works in place (flow set J1d) have been extracted from the approved TA that was prepared to support the DCO. For the purposes of this TA Addendum these are the background traffic flows. They are summarised at **Diagrams 5 and 6** for the AM and PM peak hours.
- 5.4 The 2031 total traffic flows (with the traffic from the additional mezzanine floor space) have been derived by adding the traffic associated with the mezzanine floor space (**Diagrams 3 and 4**) to the 2031 background traffic flows. The resultant 2031 total traffic flows are summarised at **Diagrams 7 and 8** for the AM and PM peak hours.

### A508 site access roundabout

- 5.5 The TA submitted in support of the DCO application demonstrated that the A508 northbound and southbound approaches to the site access roundabout were forecast to operate at 85% and 82% of their full capacity by 2031, with the Northampton Gateway SRFI fully operational.
- 5.6 A ratio of flow to capacity of 0.85 (85%) is often considered to be the upper design capacity threshold. The increase in traffic flow due to an increase in the mezzanine floor space would cause the A508 northbound approach to operate above 85% of capacity and could also push the A508 southbound approach above 85%.
- 5.7 Therefore, to facilitate an increase in the amount of permitted mezzanine floor space, an improvement scheme would be required to provide additional capacity at the site access junction and ensure its continued efficient operation.
- 5.8 Factors effecting the options to provide additional capacity at the site access roundabout are summarised as follows:
- Most of the development traffic arrives/departs to/from the north via M1 Junction 15.
  - A segregated left-turn lane on the site access arm means that northbound traffic exiting the SRFI does not enter the roundabout. The site access arm of the roundabout is therefore relatively lightly trafficked and does not require capacity enhancement.
  - The A508 northbound approach handles only around 20% of the development traffic arrivals but is opposed by the large right-turn flow arriving at the site from the north. Hence, this arm operates at capacity in the morning peak hour when the right-turn volume is greatest.
  - Improving the capacity of the A508 northbound approach would require significant carriageway widening.

- The A508 southbound approach to the roundabout has two full lanes and a flared offside lane and there is a staggered puffin crossing set back from the roundabout. This approach operates acceptably in both the morning and evening peak hours, though at 82%, it is approaching 85% of its capacity in the morning peak hour.

5.9 Following an iterative design and modelling exercise, the optimum solution was found to be upgrading the A508 southbound approach to traffic signal control on the entry and circulating carriageway. The preliminary layout of the proposed scheme<sup>5</sup> is shown at **Figure 7**.

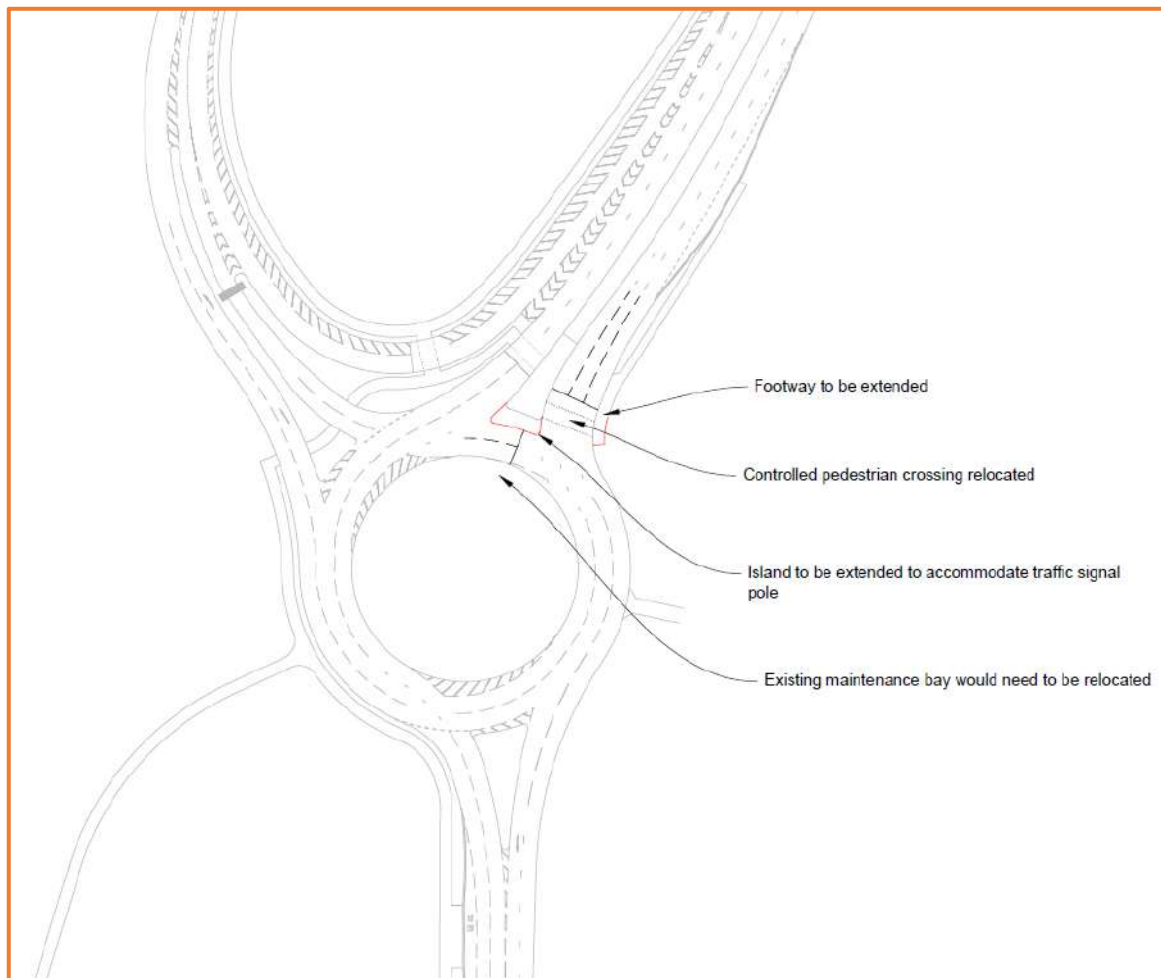

Figure 7: proposed partial signalisation of the A508 site access junction

5.10 This option was selected for the following reasons:

- Providing traffic signals on the A508 southbound arm significantly increases capacity on this approach.
- Signalising the A508 southbound approach creates gaps in the right-turning traffic into the site of 20 seconds, allowing traffic on the A508 northbound approach to enter the roundabout more easily, materially improving capacity without the need for improvement works on the A508 northbound approach.
- No carriageway widening on the A508 southbound approach would be required.
- The A508 southbound puffin crossing would effectively be relocated south so that it was at the roundabout, allowing some traffic signals equipment to be reused.
- The puffin crossing on the northbound exit from the roundabout could remain in its current location.

<sup>5</sup> Subject to agreement of the proposed scheme in principle with the local highway authority, a full drawing pack will be prepared for submission with the DCO amendment.

5.11 The operation of the site access junction has been modelling using LinSig. The modelling output is provided at the results in **Appendix B** and a summary of the results is provided at the table below.

Number	Scenario Name	Flow Group	Time	Cycle Time (s)	PRC (%)	Delay (pcuHr)
1	2031 with additional mez - AM	2031 with additional mez - AM	08:00 - 09:00	60	6.1	12.06
2	2031 with additional mez - PM	2031 with additional mez - PM	17:00 - 18:00	60	19.4	8.59

5.12 The modelling demonstrates that the junction would operate with positive practical reserve capacity (PRC) in both the morning and evening peak hours in the 2031 assessment year with the mezzanine additional floor space in place.

### M1 Junction 15

5.13 The highway improvement scheme at M1 Junction 15 was designed to provide a better than nil detriment improvement with the forecast 2031 background traffic + SRFI traffic than when compared to the previous arrangement of the junction, without the SRFI traffic. The detailed junction modelling showed that the total delay at the junction would reduce by more than 50% in both peak hours, with capacity improvements on all approaches to the junction.

5.14 However, despite the significant improvements provided, in the 2031 assessment year the junction was still forecast to operate above 100% of its capacity in the morning peak hour and below 100% of its capacity in the evening peak hour.

5.15 The controller configuration for the as-built junction improvement scheme was provided by National Highways so that the approved LinSig model could be updated to reflect the changes made to the scheme during the detailed design and implementation phases. As a result, the phase and stage arrangement and the intergreen matrices have been updated to match the controller function on-street.

5.16 The operation of the junction has been assessed using the updated LinSIG. The modelling output is provided at the results in **Appendix C** and a summary of the results is provided at the table below.

Number	Scenario Name	Flow Group	Time	Cycle Time (s)	PRC (%)	Delay (pcuHr)
1	2031 Background - AM	2031 background - AM	08:00 - 09:00	80	-22.9	325.33
2	2031 With additional mez - AM	2031 with additional mez - AM	08:00 - 09:00	80	-22.9	344.28
3	2031 Background - PM	2031 background - PM	17:00 - 18:00	76	-11.5	133.03
4	2031 With additional mez - PM	2031 with additional mez - PM	17:00 - 18:00	76	-11.5	134.52

5.17 The results show that there would be no material deterioration in the practical reserve capacity at the junction. Whilst there would be increases in delay and queueing across the model, these could not be categorised as severe. The junction would continue to operate significantly better than without the SRFI traffic and associated highway improvements.

### **Impact of additional person trips**

- 5.18 The accessibility of the site for pedestrians, cyclists, and public transport users is discussed at Section 2 of this TA Addendum.
- 5.19 As described, as part of the DCO for the Northampton Gateway, walking and cycling strategies were put in place both within the development and off-site on the highway network, including new and improved infrastructure, to provide connectivity from the SRFI site to Collingtree, Northampton, and Roade.
- 5.20 The public transport strategy for the SRFI site includes the introduction of a new bus service specifically serving the SRFI site, as well as building on the existing local bus network and providing additional bus stops on the A508 to the north and south of the A508/site access roundabout, giving access to the 33/33A and the X6 services.
- 5.21 The Northampton Gateway SRFI development will provide internal pedestrian and cyclists routes through the site, together with improved connections and complementary improvements to the external networks.
- 5.22 As assessed at Section 3, the additional mezzanine floor space could generate up to 11 additional public transport trips, and five additional walking and cycling trips during a peak hour period. These additional trips would be satisfactorily accommodated by the consented infrastructure improvements associated with the DCO. Therefore, no further assessment of the impacts of the person trips generated by the mezzanine floor space is required.

## 6.0 SUMMARY AND CONCLUSIONS

- 6.1 SEGRO Plc have commissioned ADC Infrastructure Ltd to prepare this Transport Assessment (TA) Addendum to support an application to amend the Development Consent Order (DCO) for their Northampton Gateway Strategic Rail Freight Interchange (SRFI) development.
- 6.2 The amendment to the DCO is required in response to changes in market demand, as occupiers now require much greater volumes of mezzanine floor space than was previously the case. SEGRO are therefore seeking to amend the maximum amount of mezzanine floor space that is permitted under the DCO. This will safeguard the future build out of the SRFI site by ensuring that it can provide an appropriate mix of floor space and hence remain attractive to occupiers.
- 6.3 SEGRO are seeking to increase the amount of site wide mezzanine floor space that can be delivered at Northampton Gateway SRFI by 1.2 million sqft (111,480 sqm).
- 6.4 The principle that Northampton Gateway SRFI is a suitable location for B8 employment use was established as part of the DCO for the scheme. This is reinforced by West Northamptonshire Council's New Local Plan Regulation 18 document, which puts forward the land adjacent to Northampton Gateway SRFI as suitable for B8 development.
- 6.5 As part of the DCO for Northampton Gateway, a comprehensive package of highway mitigation measures is approved and consented. The highway improvement measures include a major upgrade to M1 Junction 15 and the A45, improvements to M1 Junction 15A, a bypass for the village of Roade, the implementation of environmental weight restrictions, improvements along the A508 as part of the A508 route upgrade, and financial contributions towards improvements to the A45 Queen Eleanor Interchange, and junctions along the A5076, and a Knock Lane and Blisworth Road maintenance and minor works fund.
- 6.6 The construction of the offsite highway works commenced in 2021. Except for works on the A508 associated with the access to the Courteenhall Estate, all the highway improvements are complete and open to traffic.
- 6.7 Walking and cycling strategies were developed in agreement with the highway authorities as part of the DCO. These are in the process of being put in place both within the development and off-site on the highway network, to provide enhanced connectivity from the SRFI site for pedestrians and cyclists to Collingtree, Northampton, and Roade.
- 6.8 The internal and external footway/cycleway network provides significantly improved connections to the residential areas within the walking and cycling catchments and therefore, there are direct and safe walking and cycling routes to and from the SRFI.
- 6.9 As part of the DCO, a public transport strategy was developed which includes the introduction of a new bus service specifically serving the SRFI site, as well as building on the existing local bus network and providing additional bus stops on the A508 to the north and south of the A508/site access roundabout.
- 6.10 An assessment of the additional trips that could be generated by the additional mezzanine floor space has been undertaken using the trip rates agreed as part of the TA. The proposal to increase the mezzanine floor space allowance at the SRFI site could increase the off-site vehicle trips by 105 two-way trips in the morning peak hour and 128 two-way vehicle trips in the evening peak hour. The additional mezzanine floor space could generate up to 11 additional public transport trips, and five additional walking and cycling trips during a peak hour period. The assessment of

the traffic impact has not considered the beneficial effect of Travel Plan in reducing vehicle trips and therefore represent a robust position.

- 6.11 The impact of the additional trips on transport infrastructure has been assessed. Subject to an improvement scheme at the SRFI site access roundabout on the A508, it is concluded that the transport impacts arising of the increased mezzanine floor space would continue to be mitigated by the infrastructure improvements consented and delivered as part of the DCO, with residual impacts reduced to acceptable levels. Accordingly, there should be no objection to the proposed amendment to the DCO.

## DIAGRAMS

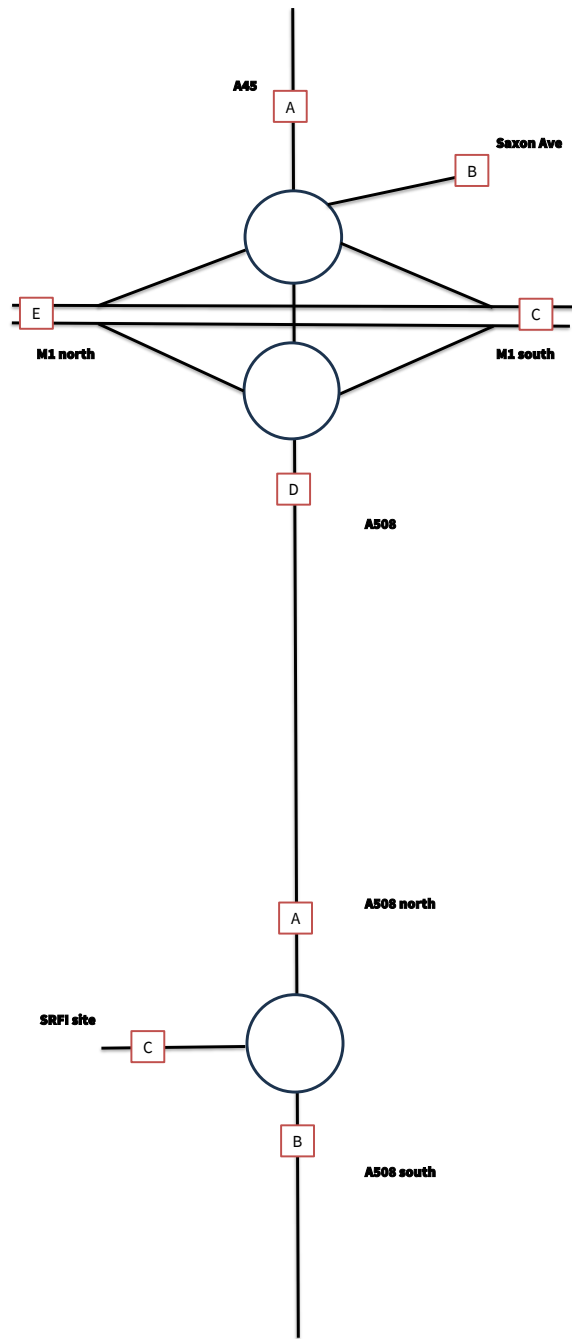

Light Vehicles						
	A	B	C	D	E	Total
A				38%		38%
B				0%		0%
C				26%		26%
D	51%	0%	14%	0%	17%	82%
E				21%		21%
Total	51%	0%	14%	85%	17%	

HGVs						
	A	B	C	D	E	Total
A				36%		36%
B				0%		0%
C				29%		29%
D	40%	0%	32%	0%	29%	100%
E				26%		26%
Total	40%	0%	32%	91%	29%	

Light Vehicles				
	A	B	C	Total
A			85%	85%
B			15%	15%
C	81%	19%		100%
Total	81%	19%	100%	

HGVs				
	A	B	C	Total
A			91%	91%
B			9%	9%
C	100%	0%		100%
Total	100%	0%	100%	

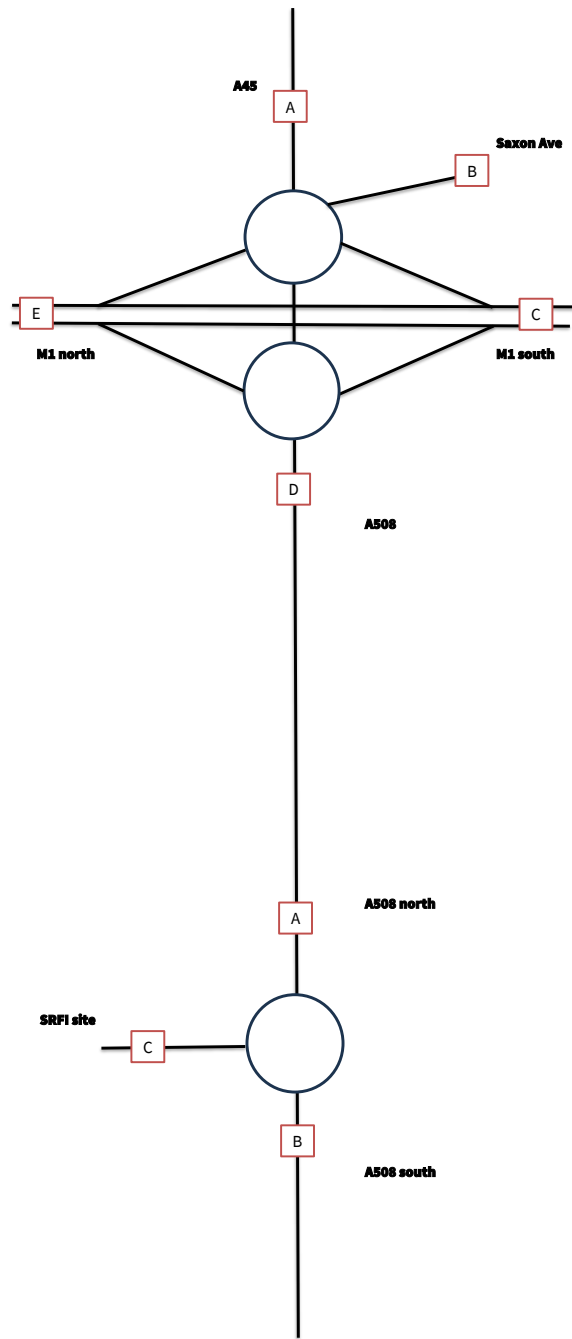

Light Vehicles						
	A	B	C	D	E	Total
A				44%		44%
B				0%		0%
C				11%		11%
D	51%	0%	19%	0%	16%	86%
E				28%		28%
<b>Total</b>	<b>51%</b>	<b>0%</b>	<b>19%</b>	<b>82%</b>	<b>16%</b>	

HGVs						
	A	B	C	D	E	Total
A				36%		36%
B				0%		0%
C				29%		29%
D	40%	0%	32%	0%	29%	100%
E				26%		26%
<b>Total</b>	<b>40%</b>	<b>0%</b>	<b>32%</b>	<b>91%</b>	<b>29%</b>	

Light Vehicles				
	A	B	C	Total
A			82%	82%
B			18%	18%
C	86%	14%		100%
<b>Total</b>	<b>86%</b>	<b>14%</b>	<b>100%</b>	

HGVs				
	A	B	C	Total
A			91%	91%
B			9%	9%
C	100%	0%		100%
<b>Total</b>	<b>100%</b>	<b>0%</b>	<b>100%</b>	

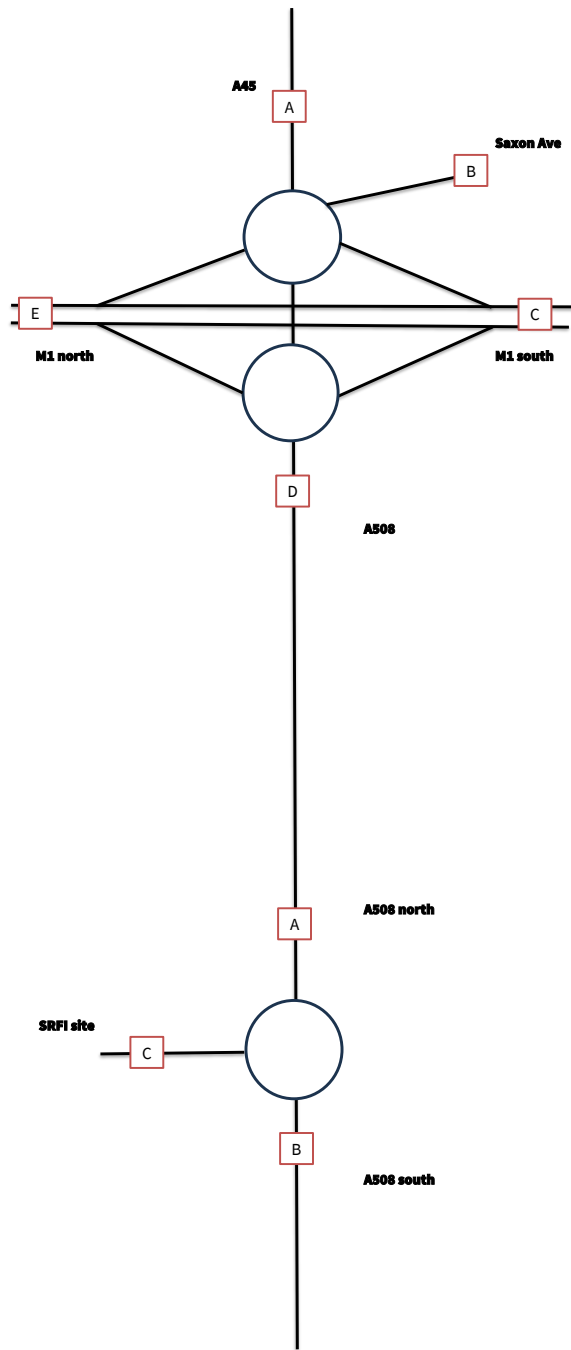

Light Vehicles						
	A	B	C	D	E	Total
A				27		27
B				0		0
C				19		19
D	4	0	1	0	1	6
E				15		15
<b>Total</b>	<b>4</b>	<b>0</b>	<b>1</b>	<b>61</b>	<b>1</b>	<b>67</b>

HGVs						
	A	B	C	D	E	Total
A				5		5
B				0		0
C				4		4
D	5	0	4	0	4	12
E				3		3
<b>Total</b>	<b>5</b>	<b>0</b>	<b>4</b>	<b>12</b>	<b>4</b>	<b>24</b>

Total Vehicles						
	A	B	C	D	E	Total
A				32		32
B				0		0
C				22		22
D	9	0	5	0	5	19
E				18		18
<b>Total</b>	<b>9</b>	<b>0</b>	<b>5</b>	<b>73</b>	<b>5</b>	<b>91</b>

PCUs						
	A	B	C	D	E	Total
A				38		38
B				0		0
C				27		27
D	15	0	10	0	9	35
E				23		23
<b>Total</b>	<b>15</b>	<b>0</b>	<b>10</b>	<b>89</b>	<b>9</b>	<b>123</b>

Light Vehicles				
	A	B	C	Total
A				61
B				11
C	6	2		8
<b>Total</b>	<b>6</b>	<b>2</b>	<b>71</b>	<b>79</b>

HGVs				
	A	B	C	Total
A				12
B				1
C	12	0		12
<b>Total</b>	<b>12</b>	<b>0</b>	<b>13</b>	<b>26</b>

Total Vehicles				
	A	B	C	Total
A				73
B				12
C	18	2		20
<b>Total</b>	<b>18</b>	<b>2</b>	<b>85</b>	<b>105</b>

PCUs				
	A	B	C	Total
A				89
B				13
C	35	2		36
<b>Total</b>	<b>35</b>	<b>2</b>	<b>102</b>	<b>138</b>

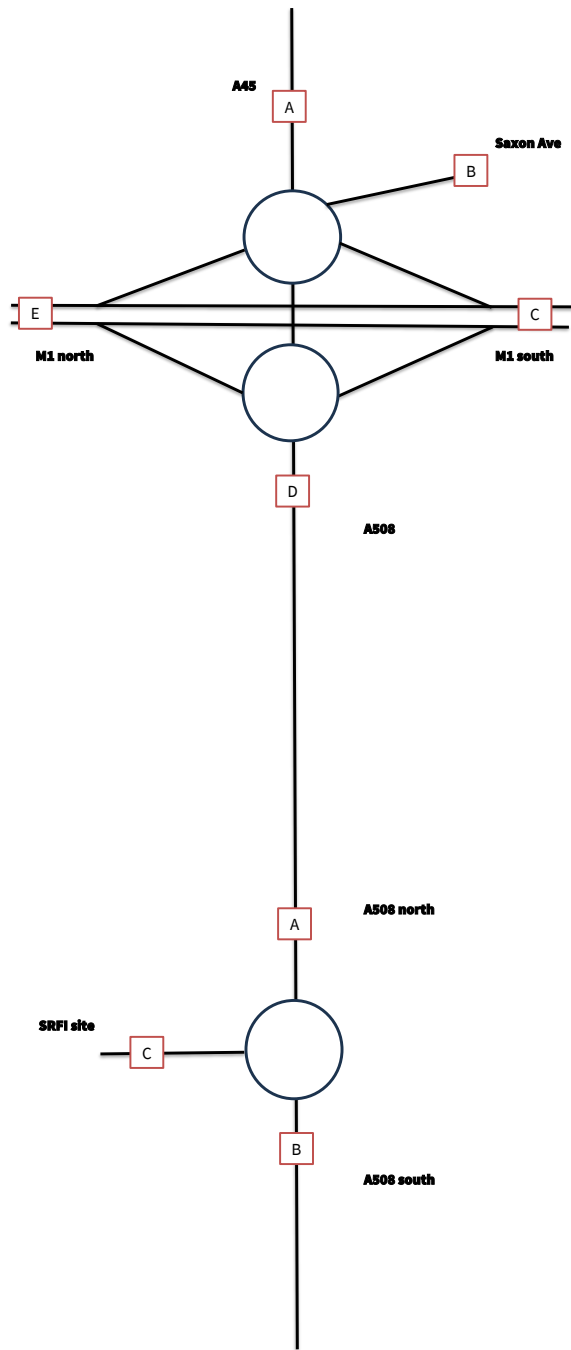

Light Vehicles						
	A	B	C	D	E	Total
A				10		10
B				0		0
C				3		3
D	42	0	16	0	13	70
E				7		7
<b>Total</b>	<b>42</b>	<b>0</b>	<b>16</b>	<b>20</b>	<b>13</b>	<b>90</b>

HGVs						
	A	B	C	D	E	Total
A				4		4
B				0		0
C				3		3
D	4	0	3	0	3	11
E				3		3
<b>Total</b>	<b>4</b>	<b>0</b>	<b>3</b>	<b>11</b>	<b>3</b>	<b>21</b>

Total Vehicles						
	A	B	C	D	E	Total
A				14		14
B				0		0
C				6		6
D	46	0	19	0	16	81
E				10		10
<b>Total</b>	<b>46</b>	<b>0</b>	<b>19</b>	<b>30</b>	<b>16</b>	<b>111</b>

PCUs						
	A	B	C	D	E	Total
A				20		20
B				0		0
C				10		10
D	51	0	23	0	20	95
E				14		14
<b>Total</b>	<b>51</b>	<b>0</b>	<b>23</b>	<b>44</b>	<b>20</b>	<b>139</b>

Light Vehicles				
	A	B	C	Total
A			19	19
B			4	4
C	70	12		82
<b>Total</b>	<b>70</b>	<b>12</b>	<b>23</b>	<b>105</b>

HGVs				
	A	B	C	Total
A			11	11
B			1	1
C	11	0		11
<b>Total</b>	<b>11</b>	<b>0</b>	<b>12</b>	<b>22</b>

Total Vehicles				
	A	B	C	Total
A			30	30
B			5	5
C	81	12		93
<b>Total</b>	<b>81</b>	<b>12</b>	<b>35</b>	<b>128</b>

PCUs				
	A	B	C	Total
A			44	44
B			7	7
C	95	12		106
<b>Total</b>	<b>95</b>	<b>12</b>	<b>50</b>	<b>157</b>

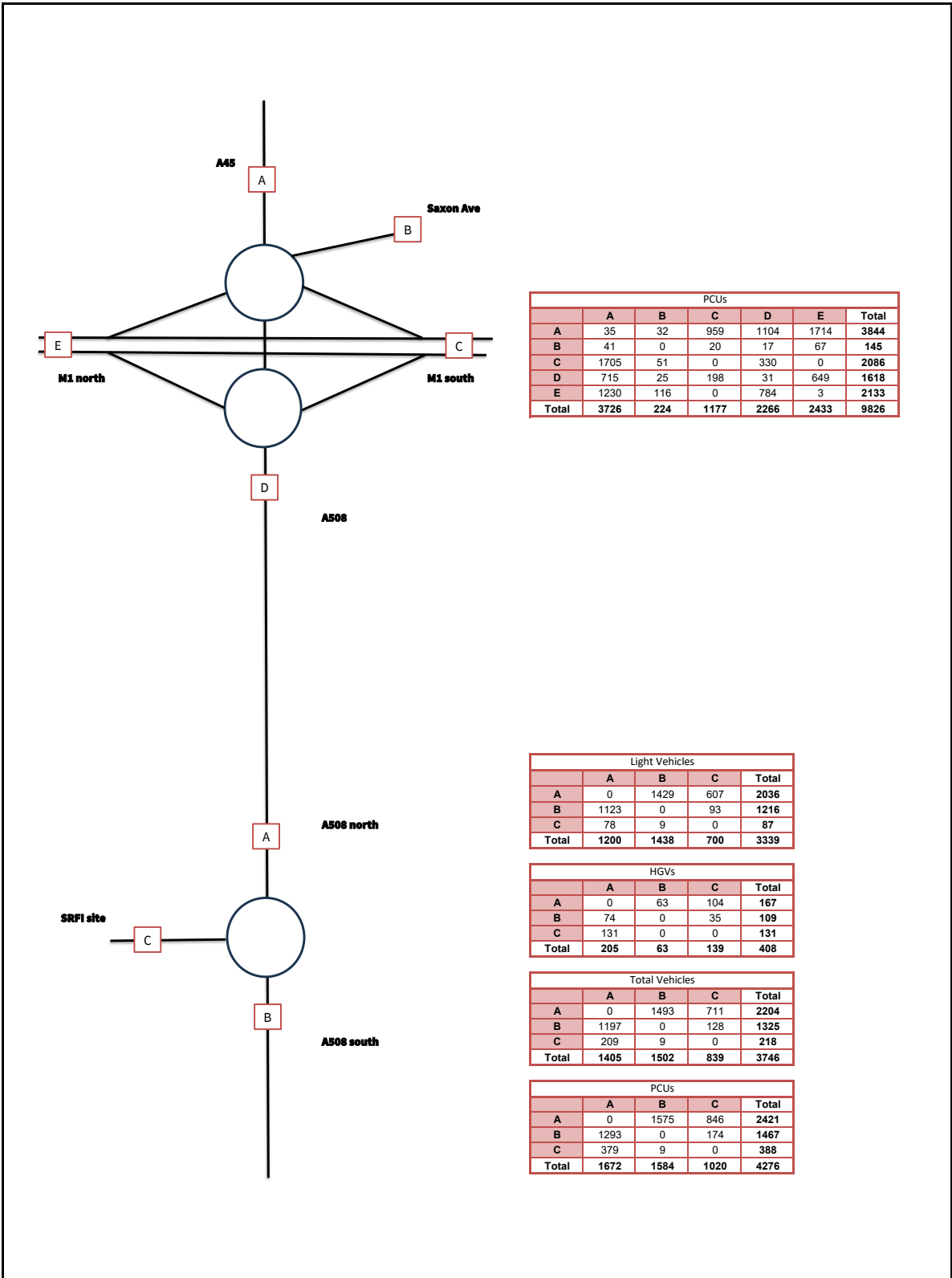

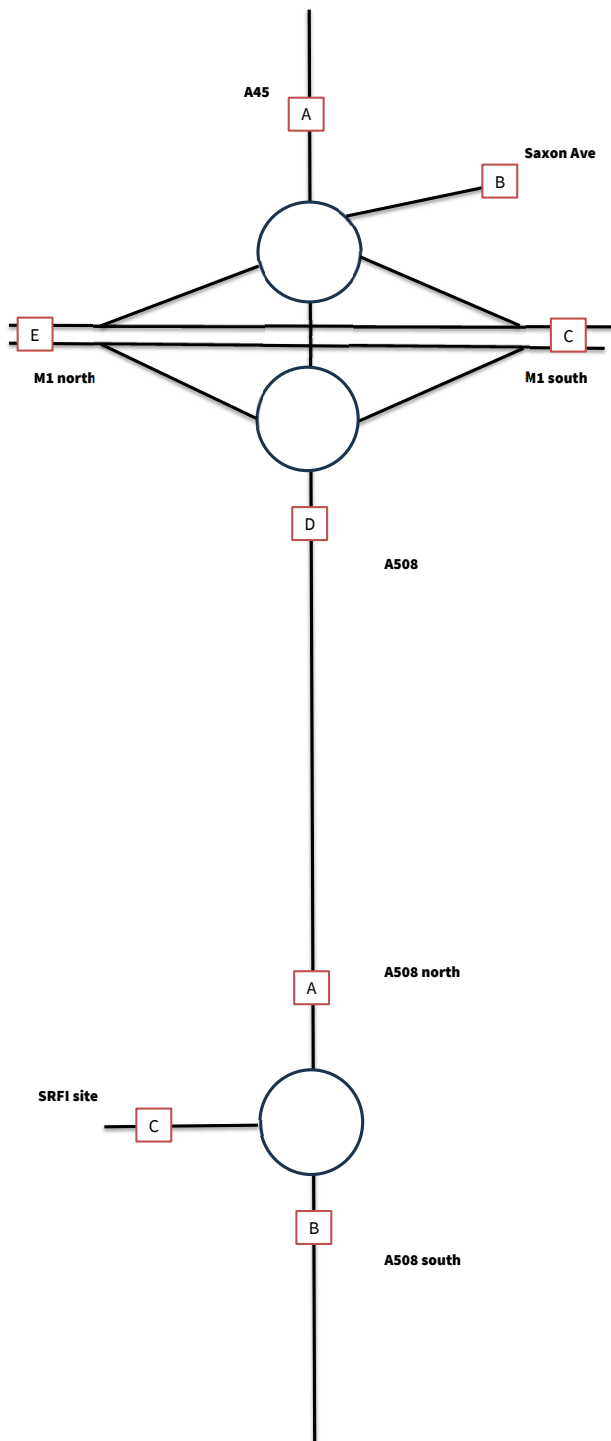

PCUs						
	A	B	C	D	E	Total
A	117	88	985	1199	1279	3668
B	30	0	121	18	100	269
C	1503	25	0	205	0	1733
D	1440	13	199	50	709	2411
E	1007	99	0	563	0	1669
Total	4097	225	1305	2035	2088	9750

Light Vehicles				
	A	B	C	Total
A	0	1466	205	1671
B	1202	0	25	1227
C	734	70	0	804
Total	1936	1535	230	3702

HGVs				
	A	B	C	Total
A	0	80	109	189
B	47	0	30	77
C	131	0	0	131
Total	178	80	139	398

Total Vehicles				
	A	B	C	Total
A	0	1546	314	1860
B	1249	0	55	1304
C	865	70	0	935
Total	2115	1616	369	4099

PCUs				
	A	B	C	Total
A	0	1651	456	2106
B	1311	0	94	1405
C	1035	70	0	1105
Total	2347	1720	550	4617

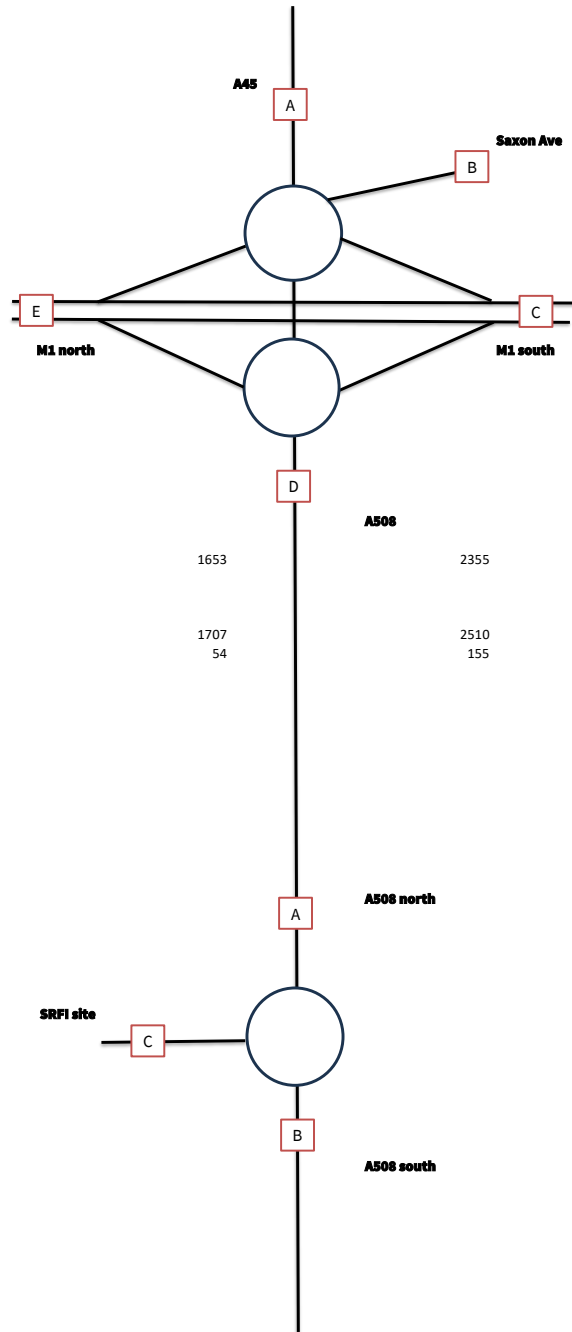

PCUs						
	A	B	C	D	E	Total
A	35	32	959	1142	1714	3882
B	41	0	20	17	67	145
C	1705	51	0	357	0	2113
D	730	25	208	31	658	1653
E	1230	116	0	807	3	2156
Total	3741	224	1187	2355	2442	9949

PCUs				
	A	B	C	Total
A	0	1575	935	2510
B	1293	0	187	1480
C	414	11	0	425
Total	1707	1586	1122	4415

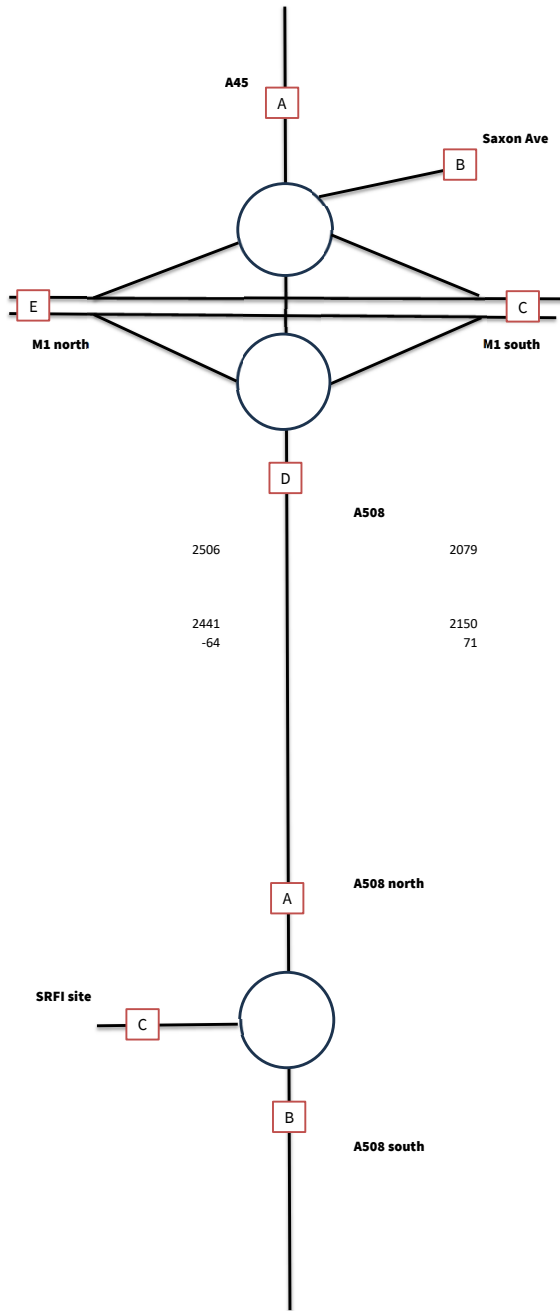

PCUs						
	A	B	C	D	E	Total
A	117	88	985	1219	1279	3688
B	30	0	121	18	100	269
C	1503	25	0	215	0	1743
D	1491	13	222	50	729	2506
E	1007	99	0	577	0	1683
Total	4148	225	1328	2079	2108	9889

2506  
2441  
-64

2079  
2150  
71

PCUs				
	A	B	C	Total
A	0	1651	499	2150
B	1311	0	101	1412
C	1130	81	0	1212
Total	2441	1732	600	4773

## APPENDIX A

# DCO PARAMETERS PLAN

**SCHEDULE OF PARAMETERS**

Zone	Number of Units	Maximum development floor space per Zone in m <sup>2</sup>	Minimum finished floor level (in m above ordnance datum)	Maximum building height measured to roof ridge / highest point (in metres above ordnance datum)
Zone A1 (a, b & c)	1 to 8	180,000	Zone A1a 81.50 Zone A1b 83.50 Zone A1c 84.00	104.00 104.00 104.00
Zone A2 (a & b)	1 to 4	152,000	Zone A2a 90.00 Zone A2b 89.50	109.50 109.50
Zone A3	1 to 4	55,000	89.00	109.50
Zone A4	1 to 4	126,000	88.50	109.00
<b>Maximum Total Floor Space Zone A*</b>				
<b>Total</b>	<b>1 to 20</b>	<b>468,000</b>		

Zone	Number of Units	Maximum development floor space per Zone in m <sup>2</sup>	Minimum finished ground level (in m above ordnance datum)	Maximum height measured to roof ridge / highest point (in metres above ordnance datum)
Zone B (Buildings)	1 to 4	1858	89.00	Buildings 103.00
(Yard)			89.00	Yard 105.00
(Cranes)			89.00	Gantry Cranes 110.50

\* this total floor space is the maximum floor space (excluding mezzanine space) that will be developed across Zone A notwithstanding that the maximum floor space stated for each Zone A1 to A4 combined would exceed this figure i.e. it is the overall floor space cap for Zone A excluding mezzanine floor space. In addition to this total floor space figure, up to 155,000 sqm (1,688,420 sqft) of floor space can be provided in the form of mezzanine floor space to units within Zone A

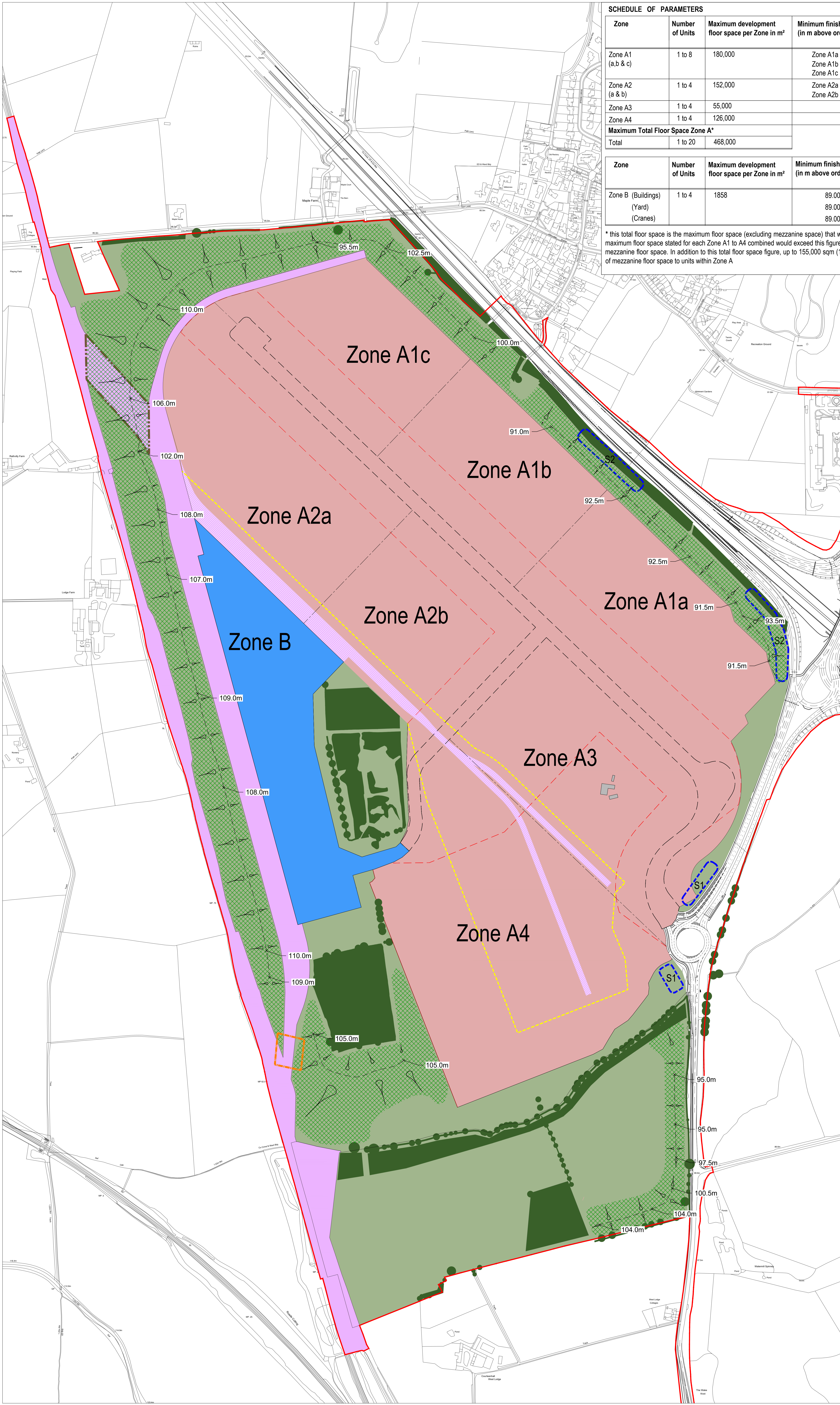

**LEGEND**

- Open Land / Landscaping including landscape screen bunding, attenuation ponds & retained agricultural land
- Existing woodland to be retained
- Estate roads
- Limits of deviation to Estate roads
- Rail corridor including new rail line and landscaping
- Rail corridor within development zones
- Limits of deviation to rail corridor within development zones
- Zone A development area
- Zone boundaries within development area
- Zone B rail freight interchange
- Order Limits
- S1 Area for development signage  
S1 = Sign Board max size (including supporting frame) 7.5m High x 18.3m Wide x 1.3m Deep
- S2 = Totem Sign max size (including supporting frame) 15.5m High x 4.0m Wide x 4.0m Deep
- Farm buildings to be demolished
- Areas within which strategic screen bunding is to be provided
- Fixed spot heights in metres above ordnance datum, identified along the ridgeline of each length of strategic screen bund
- 107.0m Between any two consecutive spot heights marked on the ridge, the height of the bund, at its ridge, will be no lower than the lower of the two spot heights and no higher than the higher of the two spot heights
- 108.0m
- Corridor for rail tunnel through strategic screen bunding
- Corridor for pedestrian footbridge over new rail line

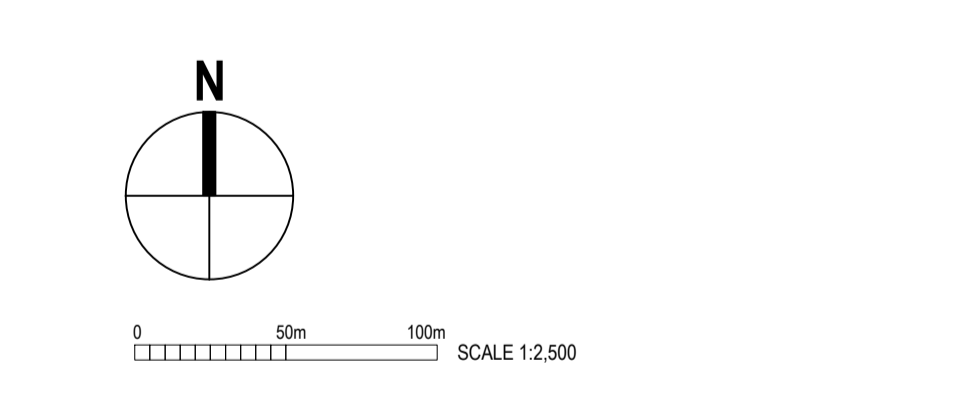

S2	11.02.2019	Rail tunnel corridor re-aligned, top of bund spot heights added	2.10	S2
Rev	Date	Details of issue / revision	Drawn	Rev

ISSUES & REVISIONS

**ROXHILL**

**NORTHAMPTON GATEWAY**  
STRATEGIC RAIL FREIGHT INTERCHANGE

**THE NORTHAMPTON GATEWAY RAIL FREIGHT INTERCHANGE ORDER 201X**

**PARAMETERS PLAN**

Scale	1:2,500	Drawn	RM
Size	A0	Reviewed	SH
Regulation	Document	Document	2.10
Regulation	<b>Reg 5(2)(o)</b>		
Drawing Status	<b>SUBMISSION</b>		
Drawing No.	4054 - R007	Revision	S2

## APPENDIX B

# A508/SITE ACCESS LINSIG ASSESSMENT RESULTS

# Full Input Data And Results

## User and Project Details

Project:	A508 site access junction mitigation
Title:	
Location:	
Client:	Segro
Additional detail:	
File name:	240514 site access gyratory - proposed mitigation.lsg3x
Author:	Mark Higgins
Company:	ADC Infrastructure Ltd
Address:	Nottingham

## Network Layout Diagram

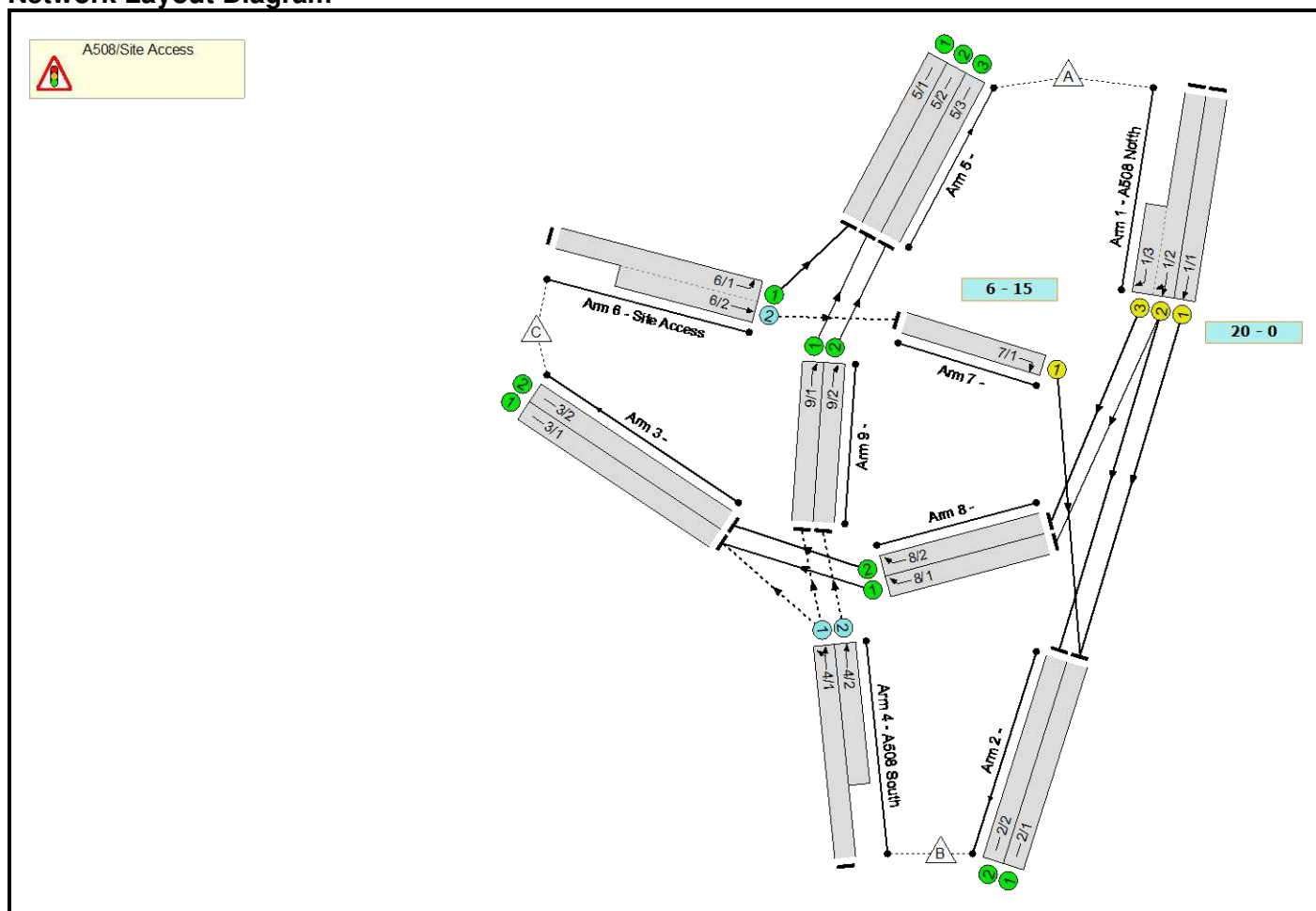

## Phase Diagram

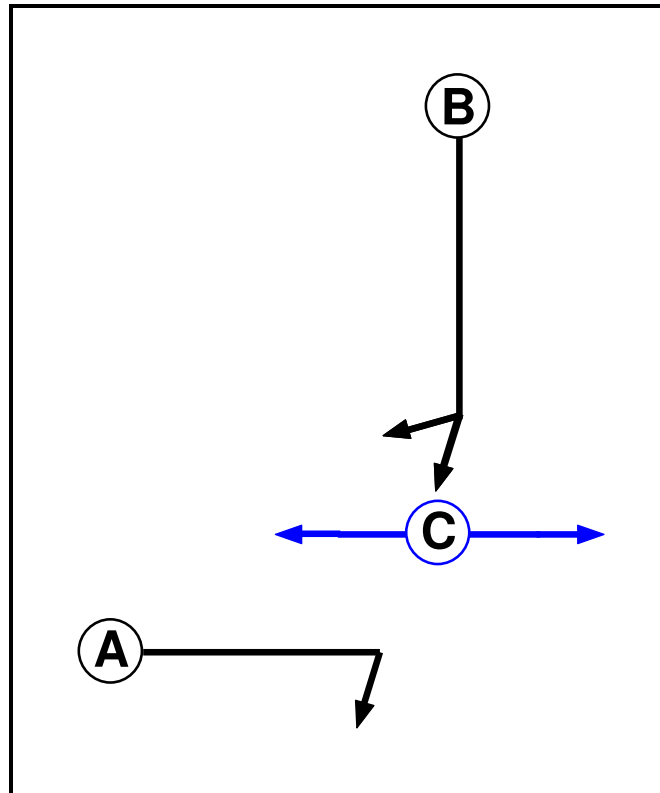

## Phase Input Data

Phase Name	Phase Type	Stage Stream	Assoc. Phase	Street Min	Cont Min
A	Traffic	1		7	4
B	Traffic	1		7	7
C	Pedestrian	1		6	6

## Phase Intergreens Matrix

	Starting Phase		
	A	B	C
Terminating Phase	A	5	-
	B	6	6
	C	-	8

## Phases in Stage

Stream	Stage No.	Phases in Stage
1	1	A C
1	2	B

### Stage Diagram

Stage Stream: 1

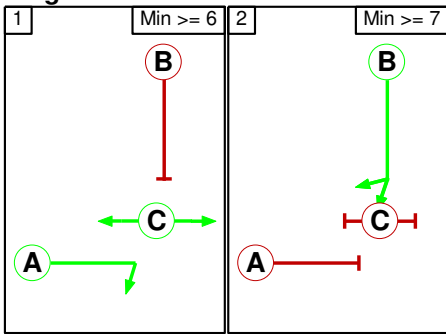

### Phase Delays

Stage Stream: 1

Term. Stage	Start Stage	Phase	Type	Value	Cont value
1	2	A	Losing	3	3

### Prohibited Stage Change

Stage Stream: 1

From Stage	To Stage	
	1	2
1		8
2	6	

### Give-Way Lane Input Data

Junction: A508/Site Access											
Lane	Movement	Max Flow when Giving Way (PCU/Hr)	Min Flow when Giving Way (PCU/Hr)	Opposing Lane	Opp. Lane Coeff.	Opp. Mvmnts.	Right Turn Storage (PCU)	Non-Blocking Storage (PCU)	RTF	Right Turn Move up (s)	Max Turns in Intergreen (PCU)
4/1 (A508 South)	3/1 (Left)	1106	0	8/1	0.25	All	-	-	-	-	-
				8/2	0.25	All					
4/2 (A508 South)	9/1 (Ahead)	1106	0	8/1	0.25	All	-	-	-	-	-
				8/2	0.25	All					
	9/2 (Ahead)	1106	0	8/1	0.25	All					
				8/2	0.25	All					
6/2 (Site Access)	7/1 (Ahead)	1000	0	9/1	0.33	All	-	-	-	-	-
				9/2	0.33	All					

## Lane Input Data

Junction: A508/Site Access												
Lane	Lane Type	Phases	Start Disp.	End Disp.	Physical Length (PCU)	Sat Flow Type	Def User Saturation Flow (PCU/Hr)	Lane Width (m)	Gradient	Nearside Lane	Turns	Turning Radius (m)
1/1 (A508 Notth)	U	B	2	3	60.0	Geom	-	3.65	0.00	Y	Arm 2 Ahead	22.00
1/2 (A508 Notth)	U	B	2	3	60.0	Geom	-	3.65	0.00	N	Arm 2 Ahead	25.00
1/3 (A508 Notth)	U	B	2	3	6.3	Geom	-	3.65	0.00	N	Arm 8 Right	25.00
2/1	U		2	3	60.0	Inf	-	-	-	-	-	-
2/2	U		2	3	60.0	Inf	-	-	-	-	-	-
3/1	U		2	3	60.0	Inf	-	-	-	-	-	-
3/2	U		2	3	60.0	Inf	-	-	-	-	-	-
4/1 (A508 South)	O		2	3	60.0	Geom	-	3.50	0.00	Y	Arm 3 Left	30.00
											Arm 9 Ahead	Inf
4/2 (A508 South)	O		2	3	10.0	Geom	-	3.50	0.00	N	Arm 9 Ahead	Inf
5/1	U		2	3	60.0	Inf	-	-	-	-	-	-
5/2	U		2	3	60.0	Inf	-	-	-	-	-	-
5/3	U		2	3	60.0	Inf	-	-	-	-	-	-
6/1 (Site Access)	U		2	3	60.0	Geom	-	3.50	0.00	Y	Arm 5 Left	30.00
6/2 (Site Access)	O		2	3	10.0	Inf	-	-	-	-	-	-
7/1	U	A	2	3	6.1	Geom	-	4.00	0.00	Y	Arm 2 Right	30.00
8/1	U		2	3	17.4	Inf	-	-	-	-	-	-
8/2	U		2	3	17.4	Inf	-	-	-	-	-	-
9/1	U		2	3	14.8	Inf	-	-	-	-	-	-
9/2	U		2	3	14.8	Inf	-	-	-	-	-	-

## Traffic Flow Groups

Flow Group	Start Time	End Time	Duration	Formula
1: '2031 with additional mez - AM'	08:00	09:00	01:00	
2: '2031 with additional mez - PM'	17:00	18:00	01:00	

**Scenario 1: '2031 with additional mez - AM'** (FG1: '2031 with additional mez - AM', Plan 1: 'Network Control Plan 1')

**Traffic Flows, Desired**

**Desired Flow :**

	Destination				
		A	B	C	Tot.
Origin	A	0	1575	935	2510
	B	1293	0	187	1480
	C	414	11	0	425
	Tot.	1707	1586	1122	4415

**Traffic Lane Flows**

Lane	Scenario 1: 2031 with additional mez - AM
<b>Junction: A508/Site Access</b>	
1/1	1050
1/2 (with short)	1460(In) 728(Out)
1/3 (short)	732
2/1	1061
2/2	525
3/1	390
3/2	732
4/1 (with short)	1480(In) 740(Out)
4/2 (short)	740
5/1	414
5/2	553
5/3	740
6/1 (with short)	425(In) 414(Out)
6/2 (short)	11
7/1	11
8/1	203
8/2	732
9/1	553
9/2	740

## Lane Saturation Flows

Junction: A508/Site Access								
Lane	Lane Width (m)	Gradient	Nearside Lane	Allowed Turns	Turning Radius (m)	Turning Prop.	Sat Flow (PCU/Hr)	Flared Sat Flow (PCU/Hr)
1/1 (A508 Notth)	3.65	0.00	Y	Arm 2 Ahead	22.00	100.0 %	1854	1854
1/2 (A508 Notth)	3.65	0.00	N	Arm 2 Ahead	25.00	72.1 %	2000	2000
				Arm 8 Right	25.00	27.9 %		
1/3 (A508 Notth)	3.65	0.00	N	Arm 8 Right	28.00	100.0 %	2012	2012
2/1	Infinite Saturation Flow						Inf	Inf
2/2	Infinite Saturation Flow						Inf	Inf
3/1	Infinite Saturation Flow						Inf	Inf
3/2	Infinite Saturation Flow						Inf	Inf
4/1 (A508 South)	3.50	0.00	Y	Arm 3 Left	30.00	25.3 %	1940	1940
				Arm 9 Ahead	Inf	74.7 %		
4/2 (A508 South)	3.50	0.00	N	Arm 9 Ahead	Inf	100.0 %	2105	2105
5/1	Infinite Saturation Flow						Inf	Inf
5/2	Infinite Saturation Flow						Inf	Inf
5/3	Infinite Saturation Flow						Inf	Inf
6/1 (Site Access)	3.50	0.00	Y	Arm 5 Left	30.00	100.0 %	1871	1871
6/2 (Site Access Lane 2)	Infinite Saturation Flow						Inf	Inf
7/1	4.00	0.00	Y	Arm 2 Right	30.00	100.0 %	1919	1919
8/1	Infinite Saturation Flow						Inf	Inf
8/2	Infinite Saturation Flow						Inf	Inf
9/1	Infinite Saturation Flow						Inf	Inf
9/2	Infinite Saturation Flow						Inf	Inf

Scenario 2: '2031 with additional mez - PM' (FG2: '2031 with additional mez - PM', Plan 1: 'Network Control Plan 1')

### Traffic Flows, Desired

#### Desired Flow :

	Destination				
	A	B	C	Tot.	
Origin	A	0	1651	499	2150
	B	1311	0	101	1412
	C	1130	81	0	1211
	Tot.	2441	1732	600	4773

## Traffic Lane Flows

Lane	Scenario 2: 2031 with additional mez - PM
<b>Junction: A508/Site Access</b>	
1/1	920
1/2 (with short)	1230(In) 731(Out)
1/3 (short)	499
2/1	1001
2/2	731
3/1	101
3/2	499
4/1 (with short)	1412(In) 709(Out)
4/2 (short)	703
5/1	1130
5/2	608
5/3	703
6/1 (with short)	1211(In) 1130(Out)
6/2 (short)	81
7/1	81
8/1	0
8/2	499
9/1	608
9/2	703

### Lane Saturation Flows

Junction: A508/Site Access								
Lane	Lane Width (m)	Gradient	Nearside Lane	Allowed Turns	Turning Radius (m)	Turning Prop.	Sat Flow (PCU/Hr)	Flared Sat Flow (PCU/Hr)
1/1 (A508 Notth)	3.65	0.00	Y	Arm 2 Ahead	22.00	100.0 %	1854	1854
1/2 (A508 Notth)	3.65	0.00	N	Arm 2 Ahead	25.00	100.0 %	2000	2000
1/3 (A508 Notth)	3.65	0.00	N	Arm 8 Right	25.00	0.0 %		
				Arm 8 Right	28.00	100.0 %	2012	2012
2/1	Infinite Saturation Flow						Inf	Inf
2/2	Infinite Saturation Flow						Inf	Inf
3/1	Infinite Saturation Flow						Inf	Inf
3/2	Infinite Saturation Flow						Inf	Inf
4/1 (A508 South)	3.50	0.00	Y	Arm 3 Left	30.00	14.2 %	1951	1951
				Arm 9 Ahead	Inf	85.8 %		
4/2 (A508 South)	3.50	0.00	N	Arm 9 Ahead	Inf	100.0 %	2105	2105
5/1	Infinite Saturation Flow						Inf	Inf
5/2	Infinite Saturation Flow						Inf	Inf
5/3	Infinite Saturation Flow						Inf	Inf
6/1 (Site Access)	3.50	0.00	Y	Arm 5 Left	30.00	100.0 %	1871	1871
6/2 (Site Access Lane 2)	Infinite Saturation Flow						Inf	Inf
7/1	4.00	0.00	Y	Arm 2 Right	30.00	100.0 %	1919	1919
8/1	Infinite Saturation Flow						Inf	Inf
8/2	Infinite Saturation Flow						Inf	Inf
9/1	Infinite Saturation Flow						Inf	Inf
9/2	Infinite Saturation Flow						Inf	Inf

### Scenario 1: '2031 with additional mez - AM' (FG1: '2031 with additional mez - AM', Plan 1: 'Network Control Plan 1')

#### Stage Sequence Diagram

#### Stage Stream: 1

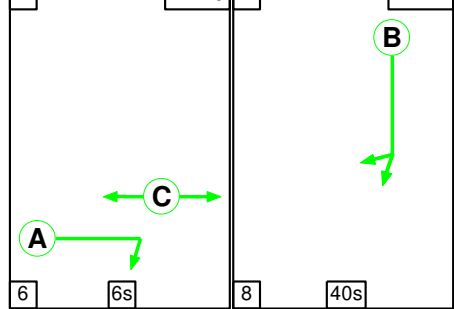

### Stage Timings

Stage Stream: 1

Stage	1	2
Duration	6	40
Change Point	0	12

### Signal Timings Diagram

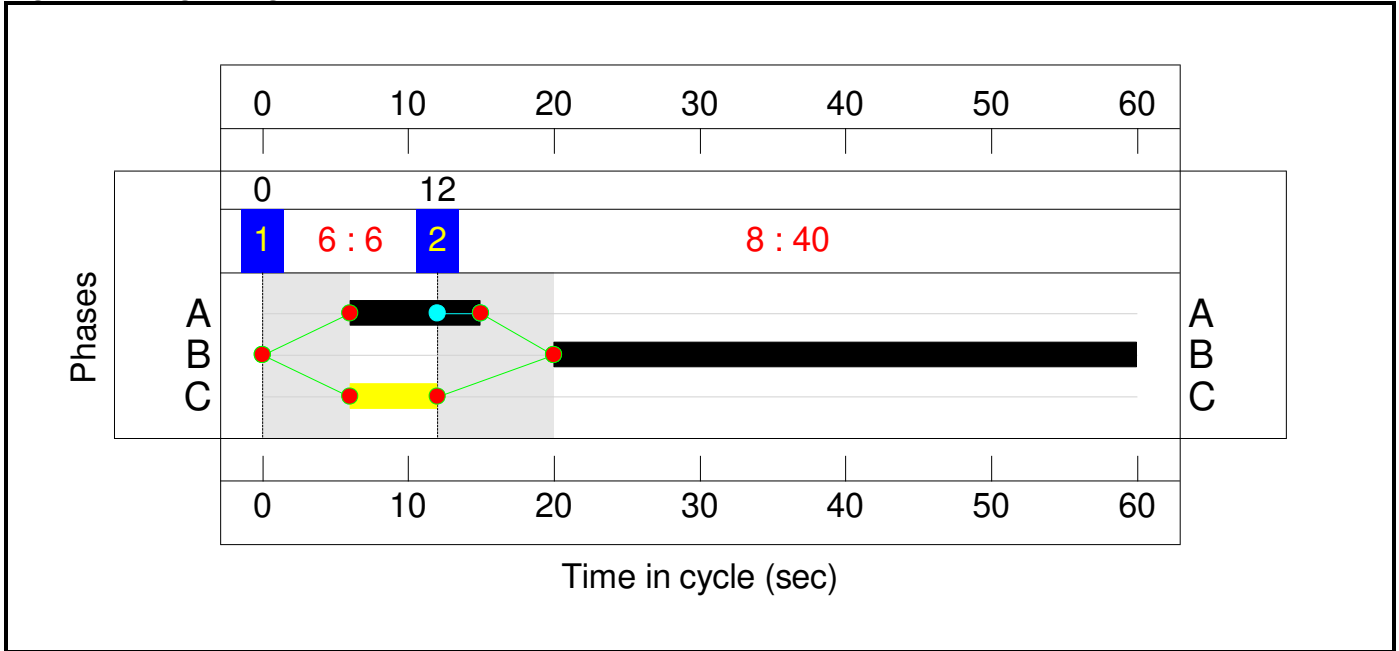

## Network Results

Item	Lane Description	Lane Type	Controller Stream	Position In Filtered Route	Full Phase	Arrow Phase	Num Greens	Total Green (s)	Arrow Green (s)	Demand Flow (pcu)	Sat Flow (pcu/Hr)	Capacity (pcu)	Deg Sat (%)
<b>Network</b>	-	-	<b>N/A</b>	-	-		-	-	-	-	-	-	<b>84.8%</b>
<b>A508/Site Access</b>	-	-	<b>N/A</b>	-	-		-	-	-	-	-	-	<b>84.8%</b>
1/1	A508 Notth Ahead	U	1	N/A	B		1	40	-	1050	1854	1267	82.9%
1/2+1/3	A508 Notth Ahead Right	U	1	N/A	B		1	40	-	1460	2000:2012	872+877	83.5 : 83.5%
4/1+4/2	A508 South Left Ahead	O	N/A	N/A	-		-	-	-	1480	1940:2105	872+872	84.8 : 84.8%
6/1+6/2	Site Access Left Ahead	U+O	N/A	N/A	-		-	-	-	425	1871: Inf	1868+50	22.2 : 22.2%
7/1	Right	U	1	N/A	A		1	9	-	11	1919	320	3.4%
Item	Arriving (pcu)	Leaving (pcu)	Turners In Gaps (pcu)	Turners When Unopposed (pcu)	Turners In Intergreen (pcu)	Uniform Delay (pcuHr)	Rand + Oversat Delay (pcuHr)	Storage Area Uniform Delay (pcuHr)	Total Delay (pcuHr)	Av. Delay Per PCU (s/pcu)	Max. Back of Uniform Queue (pcu)	Rand + Oversat Queue (pcu)	Mean Max Queue (pcu)
<b>Network</b>	-	-	<b>2971</b>	<b>0</b>	<b>0</b>	<b>4.3</b>	<b>7.8</b>	<b>0.0</b>	<b>12.1</b>	-	-	-	-
<b>A508/Site Access</b>	-	-	<b>2971</b>	<b>0</b>	<b>0</b>	<b>4.3</b>	<b>7.8</b>	<b>0.0</b>	<b>12.1</b>	-	-	-	-
1/1	1050	1050	-	-	-	2.0	2.4	-	4.4	15.1	12.5	2.4	14.9
1/2+1/3	1460	1460	-	-	-	1.9	2.5	-	4.4	10.9	5.9	2.5	8.4
4/1+4/2	1480	1480	2960	0	0	0.3	2.7	-	3.0	7.4	6.0	2.7	8.7
6/1+6/2	425	425	11	0	0	0.0	0.1	-	0.1	1.2	0.0	0.1	0.1
7/1	11	11	-	-	-	0.1	0.0	-	0.1	27.1	0.2	0.0	0.2
C1 Stream: 1 PRC for Signalled Lanes (%):					7.8	Total Delay for Signalled Lanes (pcuHr):			8.88	Cycle Time (s): 60			
PRC Over All Lanes (%):					6.1	Total Delay Over All Lanes(pcuHr):			12.06				

Scenario 2: '2031 with additional mez - PM' (FG2: '2031 with additional mez - PM', Plan 1: 'Network Control Plan 1')

### Stage Sequence Diagram

Stage Stream: 1

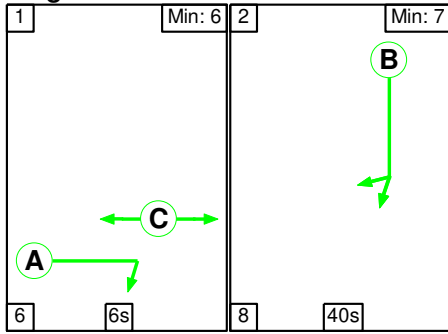

### Stage Timings

Stage Stream: 1

Stage	1	2
Duration	6	40
Change Point	0	12

### Signal Timings Diagram

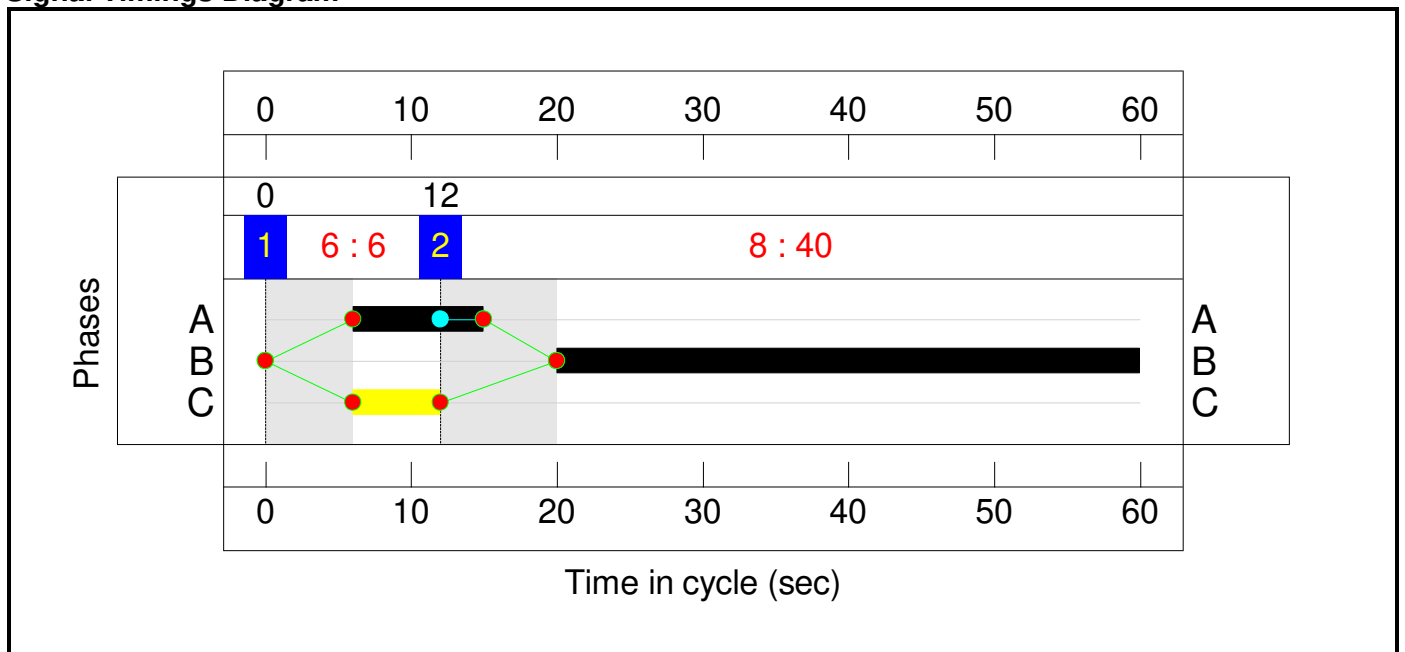

## Network Results

Item	Lane Description	Lane Type	Controller Stream	Position In Filtered Route	Full Phase	Arrow Phase	Num Greens	Total Green (s)	Arrow Green (s)	Demand Flow (pcu)	Sat Flow (pcu/Hr)	Capacity (pcu)	Deg Sat (%)
<b>Network</b>	-	-	<b>N/A</b>	-	-		-	-	-	-	-	-	<b>75.4%</b>
<b>A508/Site Access</b>	-	-	<b>N/A</b>	-	-		-	-	-	-	-	-	<b>75.4%</b>
1/1	A508 Notth Ahead	U	1	N/A	B		1	40	-	920	1854	1267	72.6%
1/2+1/3	A508 Notth Ahead Right	U	1	N/A	B		1	40	-	1230	2000:2012	970+662	75.4 : 75.4%
4/1+4/2	A508 South Left Ahead	O	N/A	N/A	-		-	-	-	1412	1951:2105	981+981	72.3 : 71.6%
6/1+6/2	Site Access Left Ahead	U+O	N/A	N/A	-		-	-	-	1211	1871: Inf	1864+134	60.6 : 60.6%
7/1	Right	U	1	N/A	A		1	9	-	81	1919	320	25.3%
Item	Arriving (pcu)	Leaving (pcu)	Turners In Gaps (pcu)	Turners When Unopposed (pcu)	Turners In Intergreen (pcu)	Uniform Delay (pcuHr)	Rand + Oversat Delay (pcuHr)	Storage Area Uniform Delay (pcuHr)	Total Delay (pcuHr)	Av. Delay Per PCU (s/pcu)	Max. Back of Uniform Queue (pcu)	Rand + Oversat Queue (pcu)	Mean Max Queue (pcu)
<b>Network</b>	-	-	<b>2905</b>	<b>0</b>	<b>0</b>	<b>3.5</b>	<b>5.1</b>	<b>0.0</b>	<b>8.6</b>	-	-	-	-
<b>A508/Site Access</b>	-	-	<b>2905</b>	<b>0</b>	<b>0</b>	<b>3.5</b>	<b>5.1</b>	<b>0.0</b>	<b>8.6</b>	-	-	-	-
1/1	920	920	-	-	-	1.5	1.3	-	2.8	11.1	9.5	1.3	10.8
1/2+1/3	1230	1230	-	-	-	1.5	1.5	-	3.0	8.9	5.9	1.5	7.4
4/1+4/2	1412	1412	2824	0	0	0.0	1.3	-	1.3	3.3	0.8	1.3	2.1
6/1+6/2	1211	1211	81	0	0	0.0	0.8	-	0.8	2.3	0.0	0.8	0.8
7/1	81	81	-	-	-	0.5	0.2	-	0.7	29.3	1.2	0.2	1.3
C1			Stream: 1 PRC for Signalled Lanes (%): 19.4			Total Delay for Signalled Lanes (pcuHr): 6.54			Cycle Time (s): 60				
			PRC Over All Lanes (%): 19.4			Total Delay Over All Lanes(pcuHr): 8.59							

## APPENDIX C

# M1 JUNCTION 15 LINSIG ASSESSMENT RESULTS

# Full Input Data And Results

## User and Project Details

Project:	Northampton Gateway
Title:	M1 Junction 15 impact with additional mezzanine
Location:	Northampton
Client:	Segro
Additional detail:	PM peak hour flows amended following feedback from NH. NB: adjustment made following removal of the Watering Lane Junction.
File name:	241101 M1 Junction 15 Mitigation - additional mez test.lsg3x
Author:	Mark Higgins
Company:	ADC Infrastructure
Address:	Nottingham

## Network Layout Diagram

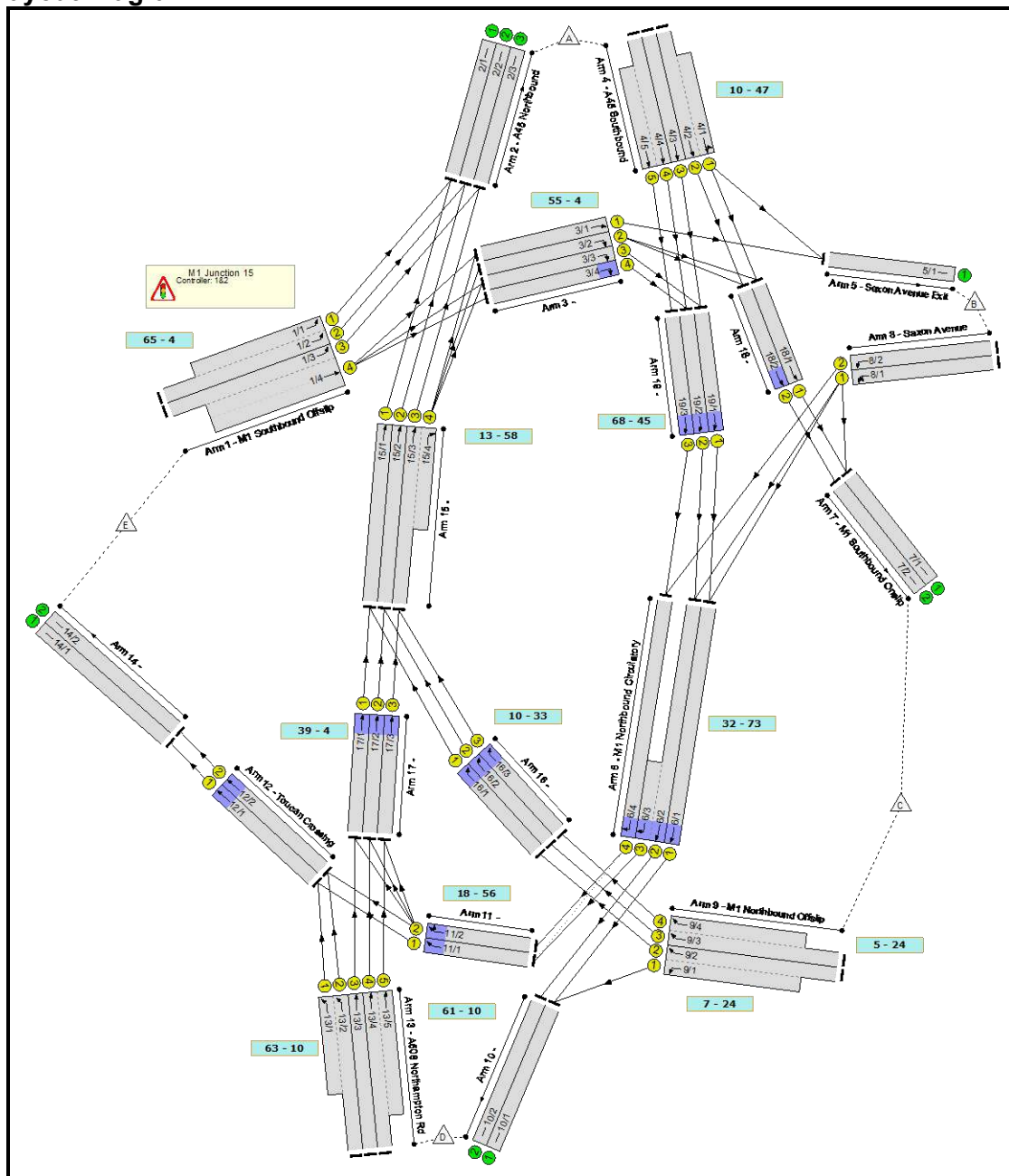

**C1 - Eastside Controller  
Phase Diagram**

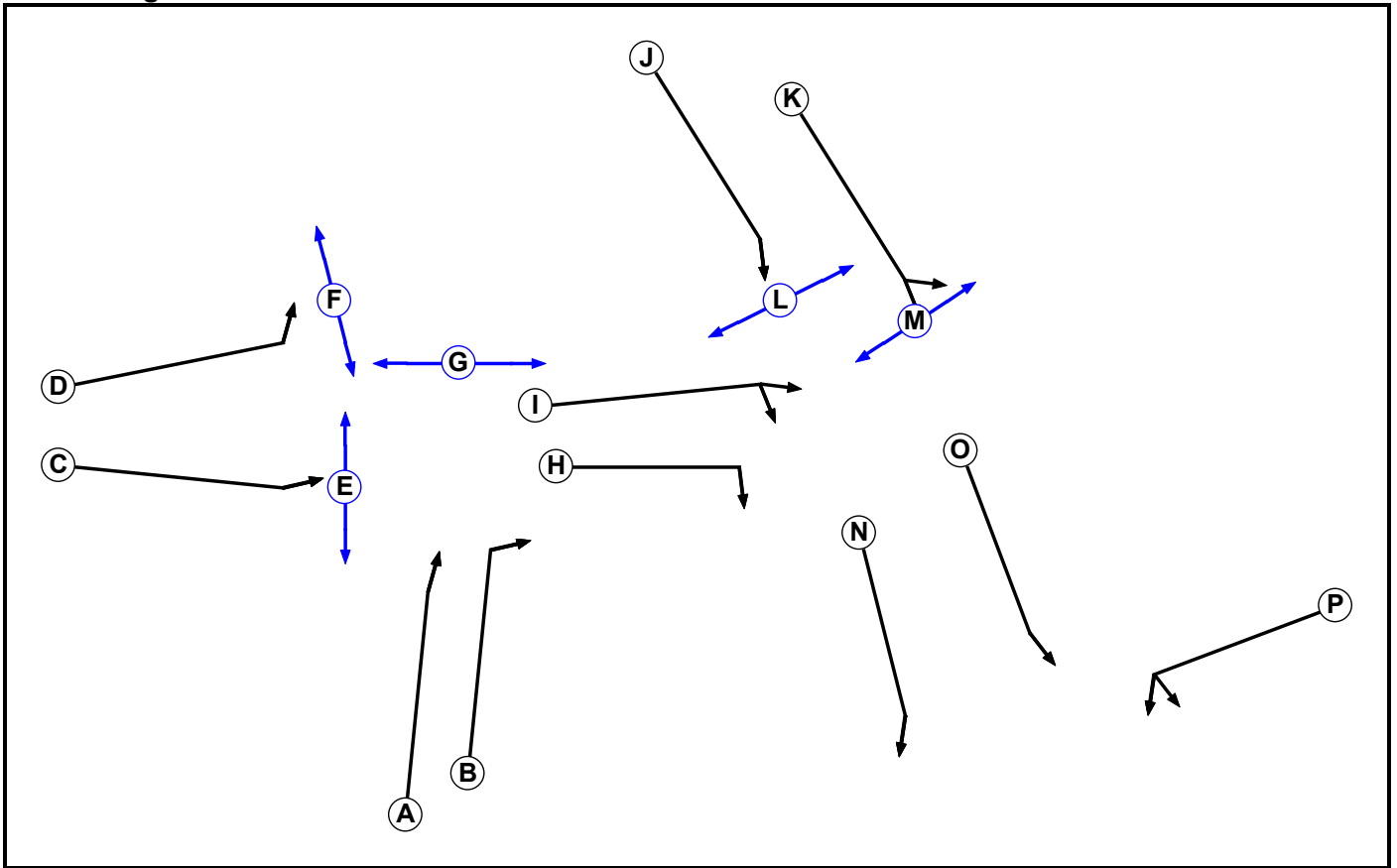

**Phase Input Data**

Phase Name	Phase Type	Stage Stream	Assoc. Phase	Street Min	Cont Min
A	Traffic	1		7	7
B	Traffic	1		7	7
C	Traffic	1		7	7
D	Traffic	1		7	7
E	Pedestrian	1		5	5
F	Pedestrian	1		5	5
G	Pedestrian	1		5	5
H	Traffic	2		7	7
I	Traffic	2		7	7
J	Traffic	2		7	7
K	Traffic	2		7	7
L	Pedestrian	2		5	5
M	Pedestrian	2		5	5
N	Traffic	3		7	7
O	Traffic	3		7	7
P	Traffic	3		7	7

## Phase Intergrens Matrix

		Starting Phase															
		A	B	C	D	E	F	G	H	I	J	K	L	M	N	O	P
Terminating Phase	A	-	-	5	7	-	-	8	-	-	-	-	-	-	-	-	-
	B	-	-	5	-	-	-	-	-	-	-	-	-	-	-	-	-
	C	9	9	-	-	7	-	-	-	-	-	-	-	-	-	-	-
	D	9	-	-	-	-	7	-	-	-	-	-	-	-	-	-	-
	E	-	-	5	-	-	-	-	-	-	-	-	-	-	-	-	-
	F	-	-	-	5	-	-	-	-	-	-	-	-	-	-	-	-
	G	5	-	-	-	-	-	-	-	-	-	-	-	-	-	-	-
	H	-	-	-	-	-	-	-	-	-	5	6	-	-	-	-	-
	I	-	-	-	-	-	-	-	-	-	5	6	-	-	-	-	-
	J	-	-	-	-	-	-	-	9	8	-	7	-	-	-	-	-
	K	-	-	-	-	-	-	-	-	7	-	-	7	-	-	-	-
	L	-	-	-	-	-	-	-	-	-	5	-	-	-	-	-	-
	M	-	-	-	-	-	-	-	-	-	-	5	-	-	-	-	-
	N	-	-	-	-	-	-	-	-	-	-	-	-	-	-	-	5
O	-	-	-	-	-	-	-	-	-	-	-	-	-	-	-	6	
P	-	-	-	-	-	-	-	-	-	-	-	-	-	-	10	7	

## Phases in Stage

Stream	Stage No.	Phases in Stage
1	1	A B E F
1	2	C D G
2	1	H I L M
2	2	J K
3	1	N O
3	2	P

## Stage Diagram

### Stage Stream: 1

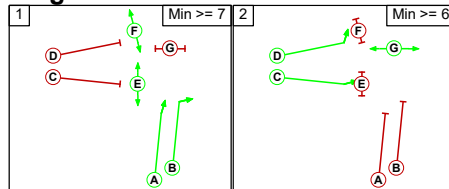

### Stage Stream: 2

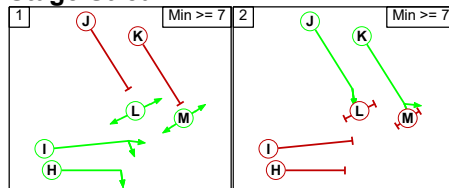

### Stage Stream: 3

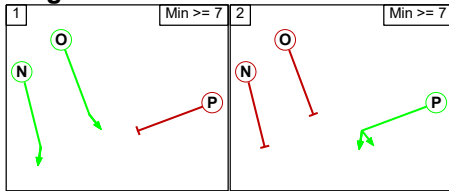

### Phase Delays

#### Stage Stream: 1

Term. Stage	Start Stage	Phase	Type	Value	Cont value
There are no Phase Delays defined					

#### Stage Stream: 2

Term. Stage	Start Stage	Phase	Type	Value	Cont value
There are no Phase Delays defined					

#### Stage Stream: 3

Term. Stage	Start Stage	Phase	Type	Value	Cont value
There are no Phase Delays defined					

### Prohibited Stage Change

#### Stage Stream: 1

From Stage	To Stage	
	1	2
1	8	
2	9	

#### Stage Stream: 2

From Stage	To Stage	
	1	2
1	6	
2	9	

#### Stage Stream: 3

From Stage	To Stage	
	1	2
1	6	
2	10	

**C2 - Westside Controller  
Phase Diagram**

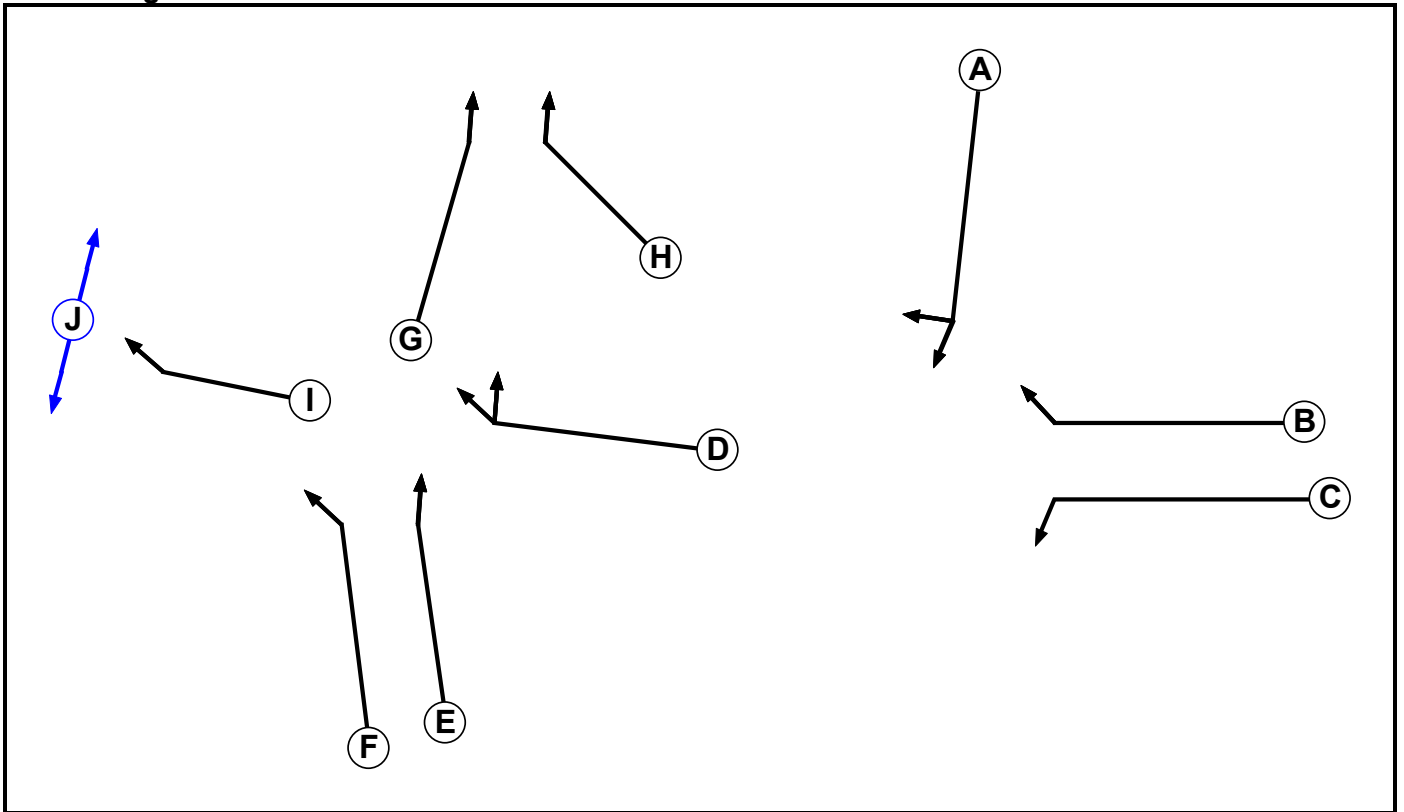

**Phase Input Data**

Phase Name	Phase Type	Stage Stream	Assoc. Phase	Street Min	Cont Min
A	Traffic	1		7	7
B	Traffic	1		7	7
C	Traffic	1		7	7
D	Traffic	2		7	7
E	Traffic	2		7	7
F	Traffic	2		7	7
G	Traffic	3		7	7
H	Traffic	3		7	7
I	Traffic	4		7	7
J	Pedestrian	4		5	5

### Phase Intergrens Matrix

		Starting Phase									
		A	B	C	D	E	F	G	H	I	J
Terminating Phase	A	8	10	-	-	-	-	-	-	-	-
	B	8	-	-	-	-	-	-	-	-	-
	C	7	-	-	-	-	-	-	-	-	-
	D	-	-	-	5	7	-	-	-	-	-
	E	-	-	-	8	-	-	-	-	-	-
	F	-	-	-	7	-	-	-	-	-	-
	G	-	-	-	-	-	-	6	-	-	-
	H	-	-	-	-	-	-	6	-	-	-
	I	-	-	-	-	-	-	-	-	7	-
	J	-	-	-	-	-	-	-	-	5	-

### Phases in Stage

Stream	Stage No.	Phases in Stage
1	1	A
1	2	B C
2	1	D
2	2	E F
3	1	G
3	2	H
4	1	I
4	2	J

### Stage Diagram

#### Stage Stream: 1

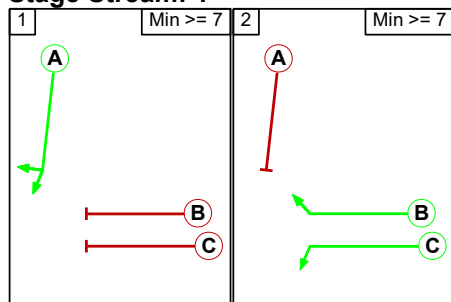

#### Stage Stream: 2

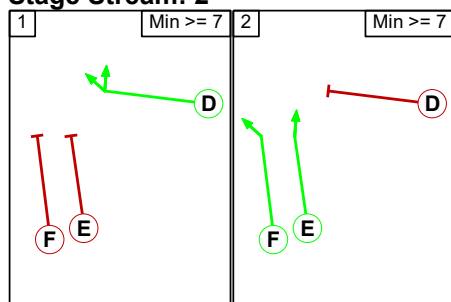

### Stage Stream: 3

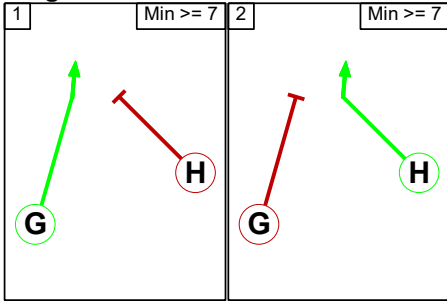

### Stage Stream: 4

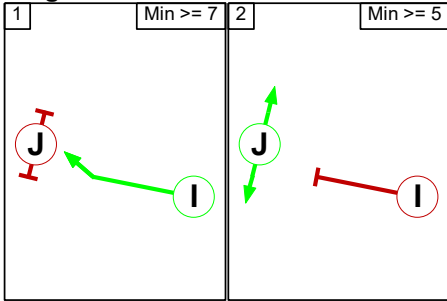

### Phase Delays

#### Stage Stream: 1

Term. Stage	Start Stage	Phase	Type	Value	Cont value
There are no Phase Delays defined					

#### Stage Stream: 2

Term. Stage	Start Stage	Phase	Type	Value	Cont value
There are no Phase Delays defined					

#### Stage Stream: 3

Term. Stage	Start Stage	Phase	Type	Value	Cont value
There are no Phase Delays defined					

#### Stage Stream: 4

Term. Stage	Start Stage	Phase	Type	Value	Cont value
There are no Phase Delays defined					

### Prohibited Stage Change

#### Stage Stream: 1

		To Stage	
		1	2
From Stage	1		10
	2	8	

#### Stage Stream: 2

		To Stage	
		1	2
From Stage	1		7
	2	8	

**Stage Stream: 3**

	To Stage	
From Stage		1 2
	1	6
	2	6

**Stage Stream: 4**

	To Stage	
From Stage		1 2
	1	7
	2	5

## Lane Input Data

Junction: M1 Junction 15												
Lane	Lane Type	Phases	Start Disp.	End Disp.	Physical Length (PCU)	Sat Flow Type	Def User Saturation Flow (PCU/Hr)	Lane Width (m)	Gradient	Nearside Lane	Turns	Turning Radius (m)
1/1 (M1 Southbound Offslip)	U	D	2	3	18.0	Geom	-	3.65	0.00	Y	Arm 2 Left	Inf
1/2 (M1 Southbound Offslip)	U	D	2	3	60.0	Geom	-	3.65	0.00	N	Arm 2 Left	Inf
1/3 (M1 Southbound Offslip)	U	D	2	3	60.0	Geom	-	3.65	0.00	N	Arm 2 Left	Inf
1/4 (M1 Southbound Offslip)	U	C	2	3	18.0	User	4000	-	-	-	-	-
2/1 (A45 Northbound)	U		2	3	4.3	Inf	-	-	-	-	-	-
2/2 (A45 Northbound)	U		2	3	4.3	Inf	-	-	-	-	-	-
2/3 (A45 Northbound)	U		2	3	4.3	Inf	-	-	-	-	-	-
3/1	U	I	2	3	11.3	User	1900	-	-	-	-	-
3/2	U	I	2	3	11.3	User	1900	-	-	-	-	-
3/3	U	H	2	3	11.3	User	1900	-	-	-	-	-
3/4	U	H	2	3	11.3	User	1900	-	-	-	-	-
4/1 (A45 Southbound)	U	K	2	3	33.0	Geom	-	3.65	0.00	Y	Arm 5 Left	Inf
											Arm 18 Ahead	Inf
4/2 (A45 Southbound)	U	K	2	3	67.8	Geom	-	3.65	0.00	N	Arm 18 Ahead	Inf
4/3 (A45 Southbound)	U	J	2	3	67.8	Geom	-	3.65	0.00	N	Arm 19 Ahead	Inf
4/4 (A45 Southbound)	U	J	2	3	67.8	Geom	-	3.65	0.00	N	Arm 19 Ahead	Inf
4/5 (A45 Southbound)	U	J	2	3	33.0	Geom	-	3.65	0.00	N	Arm 19 Ahead	Inf
5/1 (Saxon Avenue Exit)	U		2	3	4.3	Inf	-	-	-	-	-	-

6/1 (M1 Northbound Circulatory)	U	A	2	3	33.9	User	2120	-	-	-	-	-
6/2 (M1 Northbound Circulatory)	U	A	2	3	33.9	User	2120	-	-	-	-	-
6/3 (M1 Northbound Circulatory)	U	A	2	3	8.0	User	2120	-	-	-	-	-
6/4 (M1 Northbound Circulatory)	U	A	2	3	33.9	User	2120	-	-	-	-	-
7/1 (M1 Southbound Onslip)	U		2	3	4.3	Inf	-	-	-	-	-	-
7/2 (M1 Southbound Onslip)	U		2	3	4.3	Inf	-	-	-	-	-	-
8/1 (Saxon Avenue)	U	P	2	3	60.0	Geom	-	3.50	0.00	Y	Arm 6 Left	Inf
											Arm 7 Left	30.00
8/2 (Saxon Avenue)	U	P	2	3	60.0	Geom	-	3.50	0.00	N	Arm 6 Left	Inf
9/1 (M1 Northbound Offslip)	U	C	2	3	15.7	Geom	-	3.65	0.00	Y	Arm 10 Left	Inf
9/2 (M1 Northbound Offslip)	U	B	2	3	60.0	Geom	-	3.65	0.00	N	Arm 16 Ahead	Inf
9/3 (M1 Northbound Offslip)	U	B	2	3	60.0	Geom	-	3.65	0.00	N	Arm 16 Ahead	Inf
9/4 (M1 Northbound Offslip)	U	B	2	3	31.3	Geom	-	3.65	0.00	N	Arm 16 Ahead	Inf
10/1	U		2	3	4.3	Inf	-	-	-	-	-	-
10/2	U		2	3	4.3	Inf	-	-	-	-	-	-
11/1	U	D	2	3	20.0	User	1900	-	-	-	-	-
11/2	U	D	2	3	20.0	User	1900	-	-	-	-	-
12/1 (Toucan Crossing)	U	I	2	3	7.0	Geom	-	3.80	0.00	Y	Arm 14 Ahead	Inf
12/2 (Toucan Crossing)	U	I	2	3	7.0	Geom	-	3.80	0.00	Y	Arm 14 Ahead	Inf

13/1 (A508 Northampton Rd)	U	F	2	3	10.0	Geom	-	3.65	0.00	Y	Arm 12 Ahead	Inf
13/2 (A508 Northampton Rd)	U	F	2	3	60.0	Geom	-	3.65	0.00	Y	Arm 12 Ahead	Inf
13/3 (A508 Northampton Rd)	U	E	2	3	60.0	Geom	-	3.65	0.00	N	Arm 17 Ahead	Inf
13/4 (A508 Northampton Rd)	U	E	2	3	60.0	Geom	-	3.65	0.00	N	Arm 17 Ahead	Inf
13/5 (A508 Northampton Rd)	U	E	2	3	20.0	Geom	-	3.65	0.00	N	Arm 17 Ahead	Inf
14/1	U		2	3	60.0	Inf	-	-	-	-	-	-
14/2	U		2	3	60.0	Inf	-	-	-	-	-	-
15/1	U	A	2	3	34.8	User	2000	-	-	-	-	-
15/2	U	A	2	3	34.8	User	2000	-	-	-	-	-
15/3	U	A	2	3	34.8	User	2000	-	-	-	-	-
15/4	U	B	2	3	10.4	User	2000	-	-	-	-	-
16/1	U	H	2	3	10.4	User	2000	-	-	-	-	-
16/2	U	H	2	3	10.4	User	2000	-	-	-	-	-
16/3	U	H	2	3	10.4	User	2000	-	-	-	-	-
17/1	U	G	2	3	14.8	User	2000	-	-	-	-	-
17/2	U	G	2	3	14.8	User	2000	-	-	-	-	-
17/3	U	G	2	3	14.8	User	2000	-	-	-	-	-
18/1	U	O	2	3	11.3	User	2000	-	-	-	-	-
18/2	U	O	2	3	11.3	User	2000	-	-	-	-	-
19/1	U	N	2	3	13.0	User	2000	-	-	-	-	-
19/2	U	N	2	3	13.0	User	2120	-	-	-	-	-
19/3	U	N	2	3	13.0	User	2120	-	-	-	-	-

### Traffic Flow Groups

Flow Group	Start Time	End Time	Duration	Formula
1: '2031 background - AM'	08:00	09:00	01:00	
2: '2031 background - PM'	17:00	18:00	01:00	
3: '2031 with additional mez - AM'	08:00	09:00	01:00	
4: '2031 with additional mez - PM'	17:00	18:00	01:00	

**Scenario 1: '2031 Background - AM' (FG1: '2031 background - AM', Plan 1: 'Network Control Plan 1')**  
**Traffic Flows, Desired**  
**Desired Flow :**

		Destination					
		A	B	C	D	E	Tot.
Origin	A	35	32	959	1105	1714	3845
	B	41	0	20	17	67	145
	C	1705	51	0	330	0	2086
	D	715	25	198	31	649	1618
	E	1230	116	0	784	3	2133
	Tot.	3726	224	1177	2267	2433	9827

## Traffic Lane Flows

Lane	Scenario 1: 2031 Background - AM
<b>Junction: M1 Junction 15</b>	
1/1 (short)	376
1/2 (with short)	779(In) 403(Out)
1/3 (with short)	1354(In) 451(Out)
1/4 (short)	903
2/1	1299
2/2	1318
2/3	1109
3/1	192
3/2	198
3/3	319
3/4	499
4/1 (short)	493
4/2 (with short)	991(In) 498(Out)
4/3	944
4/4 (with short)	1910(In) 956(Out)
4/5 (short)	954
5/1	224
6/1	1263
6/2 (with short)	1503(In) 674(Out)
6/3 (short)	829
6/4	1031
7/1	580
7/2	597
8/1	68
8/2	77
9/1 (short)	330
9/2 (with short)	914(In) 584(Out)
9/3 (with short)	1172(In) 586(Out)
9/4 (short)	586
10/1	1593
10/2	674
11/1	900

11/2	960
12/1	1224
12/2	1209
13/1 (short)	324
13/2 (with short)	649(In) 325(Out)
13/3	304
13/4 (with short)	665(In) 329(Out)
13/5 (short)	336
14/1	1224
14/2	1209
15/1	923
15/2	915
15/3 (with short)	963(In) 658(Out)
15/4 (short)	305
16/1	584
16/2	586
16/3	586
17/1	339
17/2	329
17/3	377
18/1	560
18/2	597
19/1	1263
19/2	1455
19/3	954

## Lane Saturation Flows

Junction: M1 Junction 15								
Lane	Lane Width (m)	Gradient	Nearside Lane	Allowed Turns	Turning Radius (m)	Turning Prop.	Sat Flow (PCU/Hr)	Flared Sat Flow (PCU/Hr)
1/1 (M1 Southbound Offslip)	3.65	0.00	Y	Arm 2 Left	Inf	100.0 %	1980	1980
1/2 (M1 Southbound Offslip)	3.65	0.00	N	Arm 2 Left	Inf	100.0 %	2120	2120
1/3 (M1 Southbound Offslip)	3.65	0.00	N	Arm 2 Left	Inf	100.0 %	2120	2120
1/4 (M1 Southbound Offslip Lane 4)	This lane uses a directly entered Saturation Flow						4000	4000
2/1 (A45 Northbound Lane 1)	Infinite Saturation Flow						Inf	Inf
2/2 (A45 Northbound Lane 2)	Infinite Saturation Flow						Inf	Inf
2/3 (A45 Northbound Lane 3)	Infinite Saturation Flow						Inf	Inf
3/1	This lane uses a directly entered Saturation Flow						1900	1900
3/2	This lane uses a directly entered Saturation Flow						1900	1900
3/3	This lane uses a directly entered Saturation Flow						1900	1900
3/4	This lane uses a directly entered Saturation Flow						1900	1900
4/1 (A45 Southbound)	3.65	0.00	Y	Arm 5 Left	Inf	6.5 %	1980	1980
4/2 (A45 Southbound)				Arm 18 Ahead	Inf	93.5 %		
4/3 (A45 Southbound)	3.65	0.00	N	Arm 18 Ahead	Inf	100.0 %	2120	2120
4/4 (A45 Southbound)	3.65	0.00	N	Arm 19 Ahead	Inf	100.0 %	2120	2120
4/5 (A45 Southbound)	3.65	0.00	N	Arm 19 Ahead	Inf	100.0 %	2120	2120
5/1 (Saxon Avenue Exit Lane 1)	Infinite Saturation Flow						Inf	Inf
6/1 (M1 Northbound Circulatory Lane 1)	This lane uses a directly entered Saturation Flow						2120	2120
6/2 (M1 Northbound Circulatory Lane 2)	This lane uses a directly entered Saturation Flow						2120	2120
6/3 (M1 Northbound Circulatory Lane 3)	This lane uses a directly entered Saturation Flow						2120	2120
6/4 (M1 Northbound Circulatory Lane 4)	This lane uses a directly entered Saturation Flow						2120	2120
7/1 (M1 Southbound Onslip Lane 1)	Infinite Saturation Flow						Inf	Inf
7/2 (M1 Southbound Onslip Lane 2)	Infinite Saturation Flow						Inf	Inf

8/1 (Saxon Avenue)	3.50	0.00	Y	Arm 6 Left	Inf	70.6 %	1937	1937
				Arm 7 Left	30.00	29.4 %		
8/2 (Saxon Avenue)	3.50	0.00	N	Arm 6 Left	Inf	100.0 %	2105	2105
9/1 (M1 Northbound Offslip)	3.65	0.00	Y	Arm 10 Left	Inf	100.0 %	1980	1980
9/2 (M1 Northbound Offslip)	3.65	0.00	N	Arm 16 Ahead	Inf	100.0 %	2120	2120
9/3 (M1 Northbound Offslip)	3.65	0.00	N	Arm 16 Ahead	Inf	100.0 %	2120	2120
9/4 (M1 Northbound Offslip)	3.65	0.00	N	Arm 16 Ahead	Inf	100.0 %	2120	2120
10/1	Infinite Saturation Flow						Inf	Inf
10/2	Infinite Saturation Flow						Inf	Inf
11/1	This lane uses a directly entered Saturation Flow						1900	1900
11/2	This lane uses a directly entered Saturation Flow						1900	1900
12/1 (Toucan Crossing)	3.80	0.00	Y	Arm 14 Ahead	Inf	100.0 %	1995	1995
12/2 (Toucan Crossing)	3.80	0.00	Y	Arm 14 Ahead	Inf	100.0 %	1995	1995
13/1 (A508 Northampton Rd)	3.65	0.00	Y	Arm 12 Ahead	Inf	100.0 %	1980	1980
13/2 (A508 Northampton Rd)	3.65	0.00	Y	Arm 12 Ahead	Inf	100.0 %	1980	1980
13/3 (A508 Northampton Rd)	3.65	0.00	N	Arm 17 Ahead	Inf	100.0 %	2120	2120
13/4 (A508 Northampton Rd)	3.65	0.00	N	Arm 17 Ahead	Inf	100.0 %	2120	2120
13/5 (A508 Northampton Rd)	3.65	0.00	N	Arm 17 Ahead	Inf	100.0 %	2120	2120
14/1	Infinite Saturation Flow						Inf	Inf
14/2	Infinite Saturation Flow						Inf	Inf
15/1	This lane uses a directly entered Saturation Flow						2000	2000
15/2	This lane uses a directly entered Saturation Flow						2000	2000
15/3	This lane uses a directly entered Saturation Flow						2000	2000
15/4	This lane uses a directly entered Saturation Flow						2000	2000
16/1	This lane uses a directly entered Saturation Flow						2000	2000
16/2	This lane uses a directly entered Saturation Flow						2000	2000
16/3	This lane uses a directly entered Saturation Flow						2000	2000
17/1	This lane uses a directly entered Saturation Flow						2000	2000
17/2	This lane uses a directly entered Saturation Flow						2000	2000
17/3	This lane uses a directly entered Saturation Flow						2000	2000
18/1	This lane uses a directly entered Saturation Flow						2000	2000
18/2	This lane uses a directly entered Saturation Flow						2000	2000
19/1	This lane uses a directly entered Saturation Flow						2000	2000
19/2	This lane uses a directly entered Saturation Flow						2120	2120
19/3	This lane uses a directly entered Saturation Flow						2120	2120

**Scenario 2: '2031 With additional mez - AM'** (FG3: '2031 with additional mez - AM', Plan 1: 'Network Control Plan 1')

**Traffic Flows, Desired**

**Desired Flow :**

	Destination						
	A	B	C	D	E	Tot.	
Origin	A	35	32	959	1142	1714	3882
	B	41	0	20	17	67	145
	C	1705	51	0	357	0	2113
	D	730	25	208	31	658	1652
	E	1230	116	0	807	3	2156
	Tot.	3741	224	1187	2354	2442	9948

## Traffic Lane Flows

Lane	Scenario 2: 2031 With additional mez - AM
<b>Junction: M1 Junction 15</b>	
1/1 (short)	379
1/2 (with short)	785(In) 406(Out)
1/3 (with short)	1371(In) 445(Out)
1/4 (short)	926
2/1	1309
2/2	1330
2/3	1102
3/1	192
3/2	208
3/3	319
3/4	522
4/1 (short)	493
4/2 (with short)	991(In) 498(Out)
4/3	956
4/4 (with short)	1935(In) 968(Out)
4/5 (short)	967
5/1	224
6/1	1275
6/2 (with short)	1533(In) 722(Out)
6/3 (short)	811
6/4	1049
7/1	585
7/2	602
8/1	63
8/2	82
9/1 (short)	357
9/2 (with short)	941(In) 584(Out)
9/3 (with short)	1172(In) 586(Out)
9/4 (short)	586
10/1	1632
10/2	722
11/1	913

11/2	947
12/1	1242
12/2	1200
13/1 (short)	329
13/2 (with short)	658(In) 329(Out)
13/3	311
13/4 (with short)	683(In) 338(Out)
13/5 (short)	345
14/1	1242
14/2	1200
15/1	930
15/2	924
15/3 (with short)	972(In) 657(Out)
15/4 (short)	315
16/1	584
16/2	586
16/3	586
17/1	346
17/2	338
17/3	386
18/1	565
18/2	602
19/1	1275
19/2	1490
19/3	967

## Lane Saturation Flows

Junction: M1 Junction 15								
Lane	Lane Width (m)	Gradient	Nearside Lane	Allowed Turns	Turning Radius (m)	Turning Prop.	Sat Flow (PCU/Hr)	Flared Sat Flow (PCU/Hr)
1/1 (M1 Southbound Offslip)	3.65	0.00	Y	Arm 2 Left	Inf	100.0 %	1980	1980
1/2 (M1 Southbound Offslip)	3.65	0.00	N	Arm 2 Left	Inf	100.0 %	2120	2120
1/3 (M1 Southbound Offslip)	3.65	0.00	N	Arm 2 Left	Inf	100.0 %	2120	2120
1/4 (M1 Southbound Offslip Lane 4)	This lane uses a directly entered Saturation Flow						4000	4000
2/1 (A45 Northbound Lane 1)	Infinite Saturation Flow						Inf	Inf
2/2 (A45 Northbound Lane 2)	Infinite Saturation Flow						Inf	Inf
2/3 (A45 Northbound Lane 3)	Infinite Saturation Flow						Inf	Inf
3/1	This lane uses a directly entered Saturation Flow						1900	1900
3/2	This lane uses a directly entered Saturation Flow						1900	1900
3/3	This lane uses a directly entered Saturation Flow						1900	1900
3/4	This lane uses a directly entered Saturation Flow						1900	1900
4/1 (A45 Southbound)	3.65	0.00	Y	Arm 5 Left	Inf	6.5 %	1980	1980
				Arm 18 Ahead	Inf	93.5 %		
4/2 (A45 Southbound)	3.65	0.00	N	Arm 18 Ahead	Inf	100.0 %	2120	2120
4/3 (A45 Southbound)	3.65	0.00	N	Arm 19 Ahead	Inf	100.0 %	2120	2120
4/4 (A45 Southbound)	3.65	0.00	N	Arm 19 Ahead	Inf	100.0 %	2120	2120
4/5 (A45 Southbound)	3.65	0.00	N	Arm 19 Ahead	Inf	100.0 %	2120	2120
5/1 (Saxon Avenue Exit Lane 1)	Infinite Saturation Flow						Inf	Inf
6/1 (M1 Northbound Circulatory Lane 1)	This lane uses a directly entered Saturation Flow						2120	2120
6/2 (M1 Northbound Circulatory Lane 2)	This lane uses a directly entered Saturation Flow						2120	2120
6/3 (M1 Northbound Circulatory Lane 3)	This lane uses a directly entered Saturation Flow						2120	2120
6/4 (M1 Northbound Circulatory Lane 4)	This lane uses a directly entered Saturation Flow						2120	2120
7/1 (M1 Southbound Onslip Lane 1)	Infinite Saturation Flow						Inf	Inf
7/2 (M1 Southbound Onslip Lane 2)	Infinite Saturation Flow						Inf	Inf

8/1 (Saxon Avenue)	3.50	0.00	Y	Arm 6 Left	Inf	68.3 %	1934	1934
				Arm 7 Left	30.00	31.7 %		
8/2 (Saxon Avenue)	3.50	0.00	N	Arm 6 Left	Inf	100.0 %	2105	2105
9/1 (M1 Northbound Offslip)	3.65	0.00	Y	Arm 10 Left	Inf	100.0 %	1980	1980
9/2 (M1 Northbound Offslip)	3.65	0.00	N	Arm 16 Ahead	Inf	100.0 %	2120	2120
9/3 (M1 Northbound Offslip)	3.65	0.00	N	Arm 16 Ahead	Inf	100.0 %	2120	2120
9/4 (M1 Northbound Offslip)	3.65	0.00	N	Arm 16 Ahead	Inf	100.0 %	2120	2120
10/1	Infinite Saturation Flow						Inf	Inf
10/2	Infinite Saturation Flow						Inf	Inf
11/1	This lane uses a directly entered Saturation Flow						1900	1900
11/2	This lane uses a directly entered Saturation Flow						1900	1900
12/1 (Toucan Crossing)	3.80	0.00	Y	Arm 14 Ahead	Inf	100.0 %	1995	1995
12/2 (Toucan Crossing)	3.80	0.00	Y	Arm 14 Ahead	Inf	100.0 %	1995	1995
13/1 (A508 Northampton Rd)	3.65	0.00	Y	Arm 12 Ahead	Inf	100.0 %	1980	1980
13/2 (A508 Northampton Rd)	3.65	0.00	Y	Arm 12 Ahead	Inf	100.0 %	1980	1980
13/3 (A508 Northampton Rd)	3.65	0.00	N	Arm 17 Ahead	Inf	100.0 %	2120	2120
13/4 (A508 Northampton Rd)	3.65	0.00	N	Arm 17 Ahead	Inf	100.0 %	2120	2120
13/5 (A508 Northampton Rd)	3.65	0.00	N	Arm 17 Ahead	Inf	100.0 %	2120	2120
14/1	Infinite Saturation Flow						Inf	Inf
14/2	Infinite Saturation Flow						Inf	Inf
15/1	This lane uses a directly entered Saturation Flow						2000	2000
15/2	This lane uses a directly entered Saturation Flow						2000	2000
15/3	This lane uses a directly entered Saturation Flow						2000	2000
15/4	This lane uses a directly entered Saturation Flow						2000	2000
16/1	This lane uses a directly entered Saturation Flow						2000	2000
16/2	This lane uses a directly entered Saturation Flow						2000	2000
16/3	This lane uses a directly entered Saturation Flow						2000	2000
17/1	This lane uses a directly entered Saturation Flow						2000	2000
17/2	This lane uses a directly entered Saturation Flow						2000	2000
17/3	This lane uses a directly entered Saturation Flow						2000	2000
18/1	This lane uses a directly entered Saturation Flow						2000	2000
18/2	This lane uses a directly entered Saturation Flow						2000	2000
19/1	This lane uses a directly entered Saturation Flow						2000	2000
19/2	This lane uses a directly entered Saturation Flow						2120	2120
19/3	This lane uses a directly entered Saturation Flow						2120	2120

**Scenario 3: '2031 Background - PM '** (FG2: '2031 background - PM', Plan 1: 'Network Control Plan 1')

**Traffic Flows, Desired**

**Desired Flow :**

		Destination					
		A	B	C	D	E	Tot.
Origin	A	117	88	985	1199	1279	3668
	B	30	0	121	18	100	269
	C	1503	25	0	205	0	1733
	D	1440	13	199	50	709	2411
	E	1007	99	0	563	0	1669
	Tot.	4097	225	1305	2035	2088	9750

## Traffic Lane Flows

Lane	Scenario 3: 2031 Background - PM
<b>Junction: M1 Junction 15</b>	
1/1 (short)	292
1/2 (with short)	604(In) 312(Out)
1/3 (with short)	1065(In) 403(Out)
1/4 (short)	662
2/1	1431
2/2	1374
2/3	1292
3/1	137
3/2	199
3/3	261
3/4	352
4/1 (short)	534
4/2 (with short)	1073(In) 539(Out)
4/3	866
4/4 (with short)	1729(In) 682(Out)
4/5 (short)	1047
5/1	225
6/1	1127
6/2 (with short)	1053(In) 703(Out)
6/3 (short)	350
6/4	1176
7/1	676
7/2	629
8/1	140
8/2	129
9/1 (short)	205
9/2 (with short)	698(In) 493(Out)
9/3 (with short)	1035(In) 475(Out)
9/4 (short)	560
10/1	1332
10/2	703
11/1	656

11/2	870
12/1	1010
12/2	1078
13/1 (short)	354
13/2 (with short)	709(In) 355(Out)
13/3	516
13/4 (with short)	1186(In) 571(Out)
13/5 (short)	615
14/1	1010
14/2	1078
15/1	1139
15/2	1062
15/3 (with short)	1176(In) 889(Out)
15/4 (short)	287
16/1	493
16/2	475
16/3	560
17/1	646
17/2	587
17/3	616
18/1	555
18/2	629
19/1	1127
19/2	1034
19/3	1047

## Lane Saturation Flows

Junction: M1 Junction 15								
Lane	Lane Width (m)	Gradient	Nearside Lane	Allowed Turns	Turning Radius (m)	Turning Prop.	Sat Flow (PCU/Hr)	Flared Sat Flow (PCU/Hr)
1/1 (M1 Southbound Offslip)	3.65	0.00	Y	Arm 2 Left	Inf	100.0 %	1980	1980
1/2 (M1 Southbound Offslip)	3.65	0.00	N	Arm 2 Left	Inf	100.0 %	2120	2120
1/3 (M1 Southbound Offslip)	3.65	0.00	N	Arm 2 Left	Inf	100.0 %	2120	2120
1/4 (M1 Southbound Offslip Lane 4)	This lane uses a directly entered Saturation Flow						4000	4000
2/1 (A45 Northbound Lane 1)	Infinite Saturation Flow						Inf	Inf
2/2 (A45 Northbound Lane 2)	Infinite Saturation Flow						Inf	Inf
2/3 (A45 Northbound Lane 3)	Infinite Saturation Flow						Inf	Inf
3/1	This lane uses a directly entered Saturation Flow						1900	1900
3/2	This lane uses a directly entered Saturation Flow						1900	1900
3/3	This lane uses a directly entered Saturation Flow						1900	1900
3/4	This lane uses a directly entered Saturation Flow						1900	1900
4/1 (A45 Southbound)	3.65	0.00	Y	Arm 5 Left	Inf	16.5 %	1980	1980
				Arm 18 Ahead	Inf	83.5 %		
4/2 (A45 Southbound)	3.65	0.00	N	Arm 18 Ahead	Inf	100.0 %	2120	2120
4/3 (A45 Southbound)	3.65	0.00	N	Arm 19 Ahead	Inf	100.0 %	2120	2120
4/4 (A45 Southbound)	3.65	0.00	N	Arm 19 Ahead	Inf	100.0 %	2120	2120
4/5 (A45 Southbound)	3.65	0.00	N	Arm 19 Ahead	Inf	100.0 %	2120	2120
5/1 (Saxon Avenue Exit Lane 1)	Infinite Saturation Flow						Inf	Inf
6/1 (M1 Northbound Circulatory Lane 1)	This lane uses a directly entered Saturation Flow						2120	2120
6/2 (M1 Northbound Circulatory Lane 2)	This lane uses a directly entered Saturation Flow						2120	2120
6/3 (M1 Northbound Circulatory Lane 3)	This lane uses a directly entered Saturation Flow						2120	2120
6/4 (M1 Northbound Circulatory Lane 4)	This lane uses a directly entered Saturation Flow						2120	2120
7/1 (M1 Southbound Onslip Lane 1)	Infinite Saturation Flow						Inf	Inf
7/2 (M1 Southbound Onslip Lane 2)	Infinite Saturation Flow						Inf	Inf

8/1 (Saxon Avenue)	3.50	0.00	Y	Arm 6 Left	Inf	13.6 %	1884	1884
				Arm 7 Left	30.00	86.4 %		
8/2 (Saxon Avenue)	3.50	0.00	N	Arm 6 Left	Inf	100.0 %	2105	2105
9/1 (M1 Northbound Offslip)	3.65	0.00	Y	Arm 10 Left	Inf	100.0 %	1980	1980
9/2 (M1 Northbound Offslip)	3.65	0.00	N	Arm 16 Ahead	Inf	100.0 %	2120	2120
9/3 (M1 Northbound Offslip)	3.65	0.00	N	Arm 16 Ahead	Inf	100.0 %	2120	2120
9/4 (M1 Northbound Offslip)	3.65	0.00	N	Arm 16 Ahead	Inf	100.0 %	2120	2120
10/1	Infinite Saturation Flow						Inf	Inf
10/2	Infinite Saturation Flow						Inf	Inf
11/1	This lane uses a directly entered Saturation Flow						1900	1900
11/2	This lane uses a directly entered Saturation Flow						1900	1900
12/1 (Toucan Crossing)	3.80	0.00	Y	Arm 14 Ahead	Inf	100.0 %	1995	1995
12/2 (Toucan Crossing)	3.80	0.00	Y	Arm 14 Ahead	Inf	100.0 %	1995	1995
13/1 (A508 Northampton Rd)	3.65	0.00	Y	Arm 12 Ahead	Inf	100.0 %	1980	1980
13/2 (A508 Northampton Rd)	3.65	0.00	Y	Arm 12 Ahead	Inf	100.0 %	1980	1980
13/3 (A508 Northampton Rd)	3.65	0.00	N	Arm 17 Ahead	Inf	100.0 %	2120	2120
13/4 (A508 Northampton Rd)	3.65	0.00	N	Arm 17 Ahead	Inf	100.0 %	2120	2120
13/5 (A508 Northampton Rd)	3.65	0.00	N	Arm 17 Ahead	Inf	100.0 %	2120	2120
14/1	Infinite Saturation Flow						Inf	Inf
14/2	Infinite Saturation Flow						Inf	Inf
15/1	This lane uses a directly entered Saturation Flow						2000	2000
15/2	This lane uses a directly entered Saturation Flow						2000	2000
15/3	This lane uses a directly entered Saturation Flow						2000	2000
15/4	This lane uses a directly entered Saturation Flow						2000	2000
16/1	This lane uses a directly entered Saturation Flow						2000	2000
16/2	This lane uses a directly entered Saturation Flow						2000	2000
16/3	This lane uses a directly entered Saturation Flow						2000	2000
17/1	This lane uses a directly entered Saturation Flow						2000	2000
17/2	This lane uses a directly entered Saturation Flow						2000	2000
17/3	This lane uses a directly entered Saturation Flow						2000	2000
18/1	This lane uses a directly entered Saturation Flow						2000	2000
18/2	This lane uses a directly entered Saturation Flow						2000	2000
19/1	This lane uses a directly entered Saturation Flow						2000	2000
19/2	This lane uses a directly entered Saturation Flow						2120	2120
19/3	This lane uses a directly entered Saturation Flow						2120	2120

**Scenario 4: '2031 With additional mez - PM '** (FG4: '2031 with additional mez - PM', Plan 1: 'Network Control Plan 1')

**Traffic Flows, Desired**

**Desired Flow :**

	Destination						
	A	B	C	D	E	Tot.	
Origin	A	117	88	985	1219	1279	3688
	B	30	0	121	18	100	269
	C	1503	25	0	215	0	1743
	D	1491	13	222	50	729	2505
	E	1007	99	0	577	0	1683
	Tot.	4148	225	1328	2079	2108	9888

## Traffic Lane Flows

Lane	Scenario 4: 2031 With additional mez - PM
<b>Junction: M1 Junction 15</b>	
1/1 (short)	293
1/2 (with short)	607(In) 314(Out)
1/3 (with short)	1076(In) 400(Out)
1/4 (short)	676
2/1	1464
2/2	1403
2/3	1281
3/1	137
3/2	222
3/3	274
3/4	353
4/1 (short)	534
4/2 (with short)	1073(In) 539(Out)
4/3	866
4/4 (with short)	1749(In) 702(Out)
4/5 (short)	1047
5/1	225
6/1	1140
6/2 (with short)	1074(In) 724(Out)
6/3 (short)	350
6/4	1176
7/1	687
7/2	641
8/1	140
8/2	129
9/1 (short)	215
9/2 (with short)	716(In) 501(Out)
9/3 (with short)	1027(In) 474(Out)
9/4 (short)	553
10/1	1355
10/2	724
11/1	652

11/2	874
12/1	1016
12/2	1092
13/1 (short)	364
13/2 (with short)	729(In) 365(Out)
13/3	545
13/4 (with short)	1231(In) 593(Out)
13/5 (short)	638
14/1	1016
14/2	1092
15/1	1171
15/2	1089
15/3 (with short)	1191(In) 881(Out)
15/4 (short)	310
16/1	501
16/2	474
16/3	553
17/1	670
17/2	615
17/3	638
18/1	566
18/2	641
19/1	1140
19/2	1055
19/3	1047

## Lane Saturation Flows

Junction: M1 Junction 15								
Lane	Lane Width (m)	Gradient	Nearside Lane	Allowed Turns	Turning Radius (m)	Turning Prop.	Sat Flow (PCU/Hr)	Flared Sat Flow (PCU/Hr)
1/1 (M1 Southbound Offslip)	3.65	0.00	Y	Arm 2 Left	Inf	100.0 %	1980	1980
1/2 (M1 Southbound Offslip)	3.65	0.00	N	Arm 2 Left	Inf	100.0 %	2120	2120
1/3 (M1 Southbound Offslip)	3.65	0.00	N	Arm 2 Left	Inf	100.0 %	2120	2120
1/4 (M1 Southbound Offslip Lane 4)	This lane uses a directly entered Saturation Flow						4000	4000
2/1 (A45 Northbound Lane 1)	Infinite Saturation Flow						Inf	Inf
2/2 (A45 Northbound Lane 2)	Infinite Saturation Flow						Inf	Inf
2/3 (A45 Northbound Lane 3)	Infinite Saturation Flow						Inf	Inf
3/1	This lane uses a directly entered Saturation Flow						1900	1900
3/2	This lane uses a directly entered Saturation Flow						1900	1900
3/3	This lane uses a directly entered Saturation Flow						1900	1900
3/4	This lane uses a directly entered Saturation Flow						1900	1900
4/1 (A45 Southbound)	3.65	0.00	Y	Arm 5 Left	Inf	16.5 %	1980	1980
				Arm 18 Ahead	Inf	83.5 %		
4/2 (A45 Southbound)	3.65	0.00	N	Arm 18 Ahead	Inf	100.0 %	2120	2120
4/3 (A45 Southbound)	3.65	0.00	N	Arm 19 Ahead	Inf	100.0 %	2120	2120
4/4 (A45 Southbound)	3.65	0.00	N	Arm 19 Ahead	Inf	100.0 %	2120	2120
4/5 (A45 Southbound)	3.65	0.00	N	Arm 19 Ahead	Inf	100.0 %	2120	2120
5/1 (Saxon Avenue Exit Lane 1)	Infinite Saturation Flow						Inf	Inf
6/1 (M1 Northbound Circulatory Lane 1)	This lane uses a directly entered Saturation Flow						2120	2120
6/2 (M1 Northbound Circulatory Lane 2)	This lane uses a directly entered Saturation Flow						2120	2120
6/3 (M1 Northbound Circulatory Lane 3)	This lane uses a directly entered Saturation Flow						2120	2120
6/4 (M1 Northbound Circulatory Lane 4)	This lane uses a directly entered Saturation Flow						2120	2120
7/1 (M1 Southbound Onslip Lane 1)	Infinite Saturation Flow						Inf	Inf
7/2 (M1 Southbound Onslip Lane 2)	Infinite Saturation Flow						Inf	Inf

8/1 (Saxon Avenue)	3.50	0.00	Y	Arm 6 Left	Inf	13.6 %	1884	1884
				Arm 7 Left	30.00	86.4 %		
8/2 (Saxon Avenue)	3.50	0.00	N	Arm 6 Left	Inf	100.0 %	2105	2105
9/1 (M1 Northbound Offslip)	3.65	0.00	Y	Arm 10 Left	Inf	100.0 %	1980	1980
9/2 (M1 Northbound Offslip)	3.65	0.00	N	Arm 16 Ahead	Inf	100.0 %	2120	2120
9/3 (M1 Northbound Offslip)	3.65	0.00	N	Arm 16 Ahead	Inf	100.0 %	2120	2120
9/4 (M1 Northbound Offslip)	3.65	0.00	N	Arm 16 Ahead	Inf	100.0 %	2120	2120
10/1	Infinite Saturation Flow						Inf	Inf
10/2	Infinite Saturation Flow						Inf	Inf
11/1	This lane uses a directly entered Saturation Flow						1900	1900
11/2	This lane uses a directly entered Saturation Flow						1900	1900
12/1 (Toucan Crossing)	3.80	0.00	Y	Arm 14 Ahead	Inf	100.0 %	1995	1995
12/2 (Toucan Crossing)	3.80	0.00	Y	Arm 14 Ahead	Inf	100.0 %	1995	1995
13/1 (A508 Northampton Rd)	3.65	0.00	Y	Arm 12 Ahead	Inf	100.0 %	1980	1980
13/2 (A508 Northampton Rd)	3.65	0.00	Y	Arm 12 Ahead	Inf	100.0 %	1980	1980
13/3 (A508 Northampton Rd)	3.65	0.00	N	Arm 17 Ahead	Inf	100.0 %	2120	2120
13/4 (A508 Northampton Rd)	3.65	0.00	N	Arm 17 Ahead	Inf	100.0 %	2120	2120
13/5 (A508 Northampton Rd)	3.65	0.00	N	Arm 17 Ahead	Inf	100.0 %	2120	2120
14/1	Infinite Saturation Flow						Inf	Inf
14/2	Infinite Saturation Flow						Inf	Inf
15/1	This lane uses a directly entered Saturation Flow						2000	2000
15/2	This lane uses a directly entered Saturation Flow						2000	2000
15/3	This lane uses a directly entered Saturation Flow						2000	2000
15/4	This lane uses a directly entered Saturation Flow						2000	2000
16/1	This lane uses a directly entered Saturation Flow						2000	2000
16/2	This lane uses a directly entered Saturation Flow						2000	2000
16/3	This lane uses a directly entered Saturation Flow						2000	2000
17/1	This lane uses a directly entered Saturation Flow						2000	2000
17/2	This lane uses a directly entered Saturation Flow						2000	2000
17/3	This lane uses a directly entered Saturation Flow						2000	2000
18/1	This lane uses a directly entered Saturation Flow						2000	2000
18/2	This lane uses a directly entered Saturation Flow						2000	2000
19/1	This lane uses a directly entered Saturation Flow						2000	2000
19/2	This lane uses a directly entered Saturation Flow						2120	2120
19/3	This lane uses a directly entered Saturation Flow						2120	2120

**Scenario 1: '2031 Background - AM'** (FG1: '2031 background - AM', Plan 1: 'Network Control Plan 1')

**C1 - Eastside Controller**

**Stage Sequence Diagram**

**Stage Stream: 1**

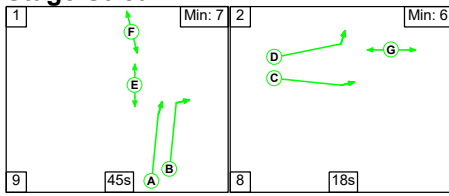

**Stage Stream: 2**

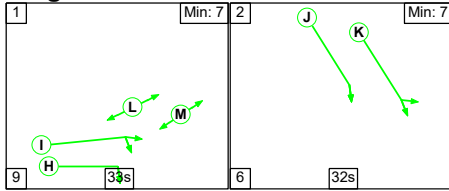

**Stage Stream: 3**

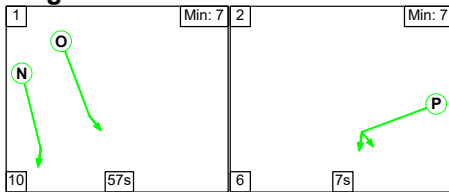

**Stage Timings**

**Stage Stream: 1**

Stage	1	2
Duration	45	18
Change Point	67	41

**Stage Stream: 2**

Stage	1	2
Duration	33	32
Change Point	30	72

**Stage Stream: 3**

Stage	1	2
Duration	57	7
Change Point	47	34

# Signal Timings Diagram

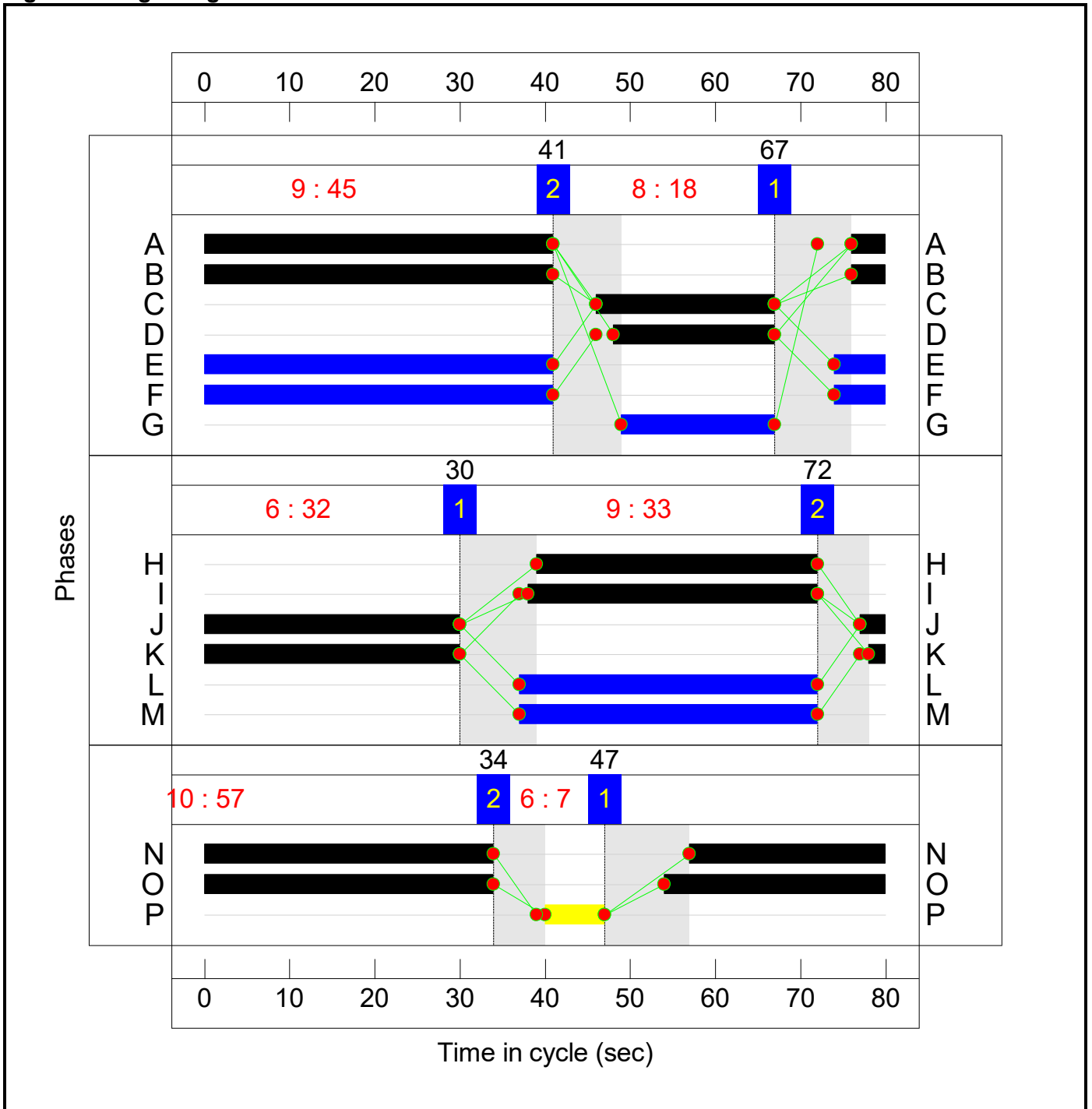

## C2 - Westside Controller Stage Sequence Diagram Stage Stream: 1

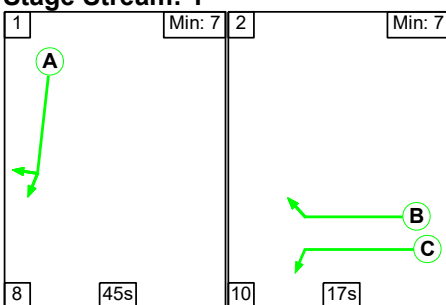

### Stage Stream: 2

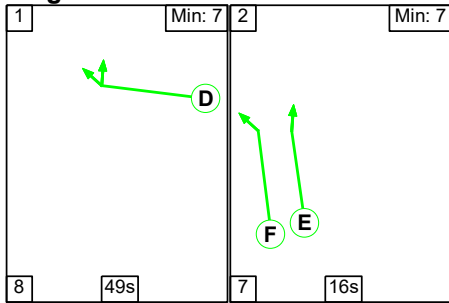

### Stage Stream: 3

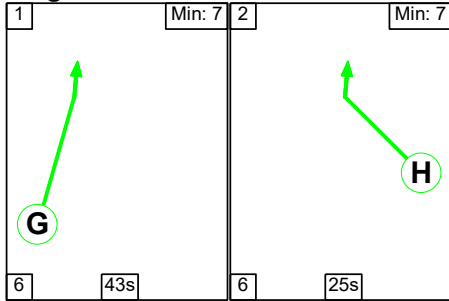

### Stage Stream: 4

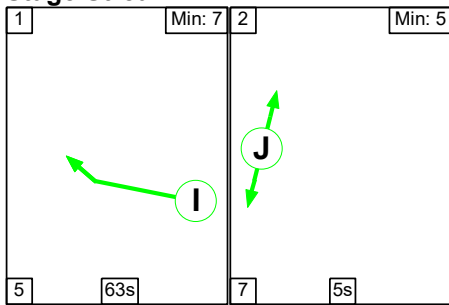

### Stage Timings

#### Stage Stream: 1

Stage	1	2
Duration	45	17
Change Point	24	77

#### Stage Stream: 2

Stage	1	2
Duration	49	16
Change Point	10	67

#### Stage Stream: 3

Stage	1	2
Duration	43	25
Change Point	35	4

#### Stage Stream: 4

Stage	1	2
Duration	63	5
Change Point	20	8

# Signal Timings Diagram

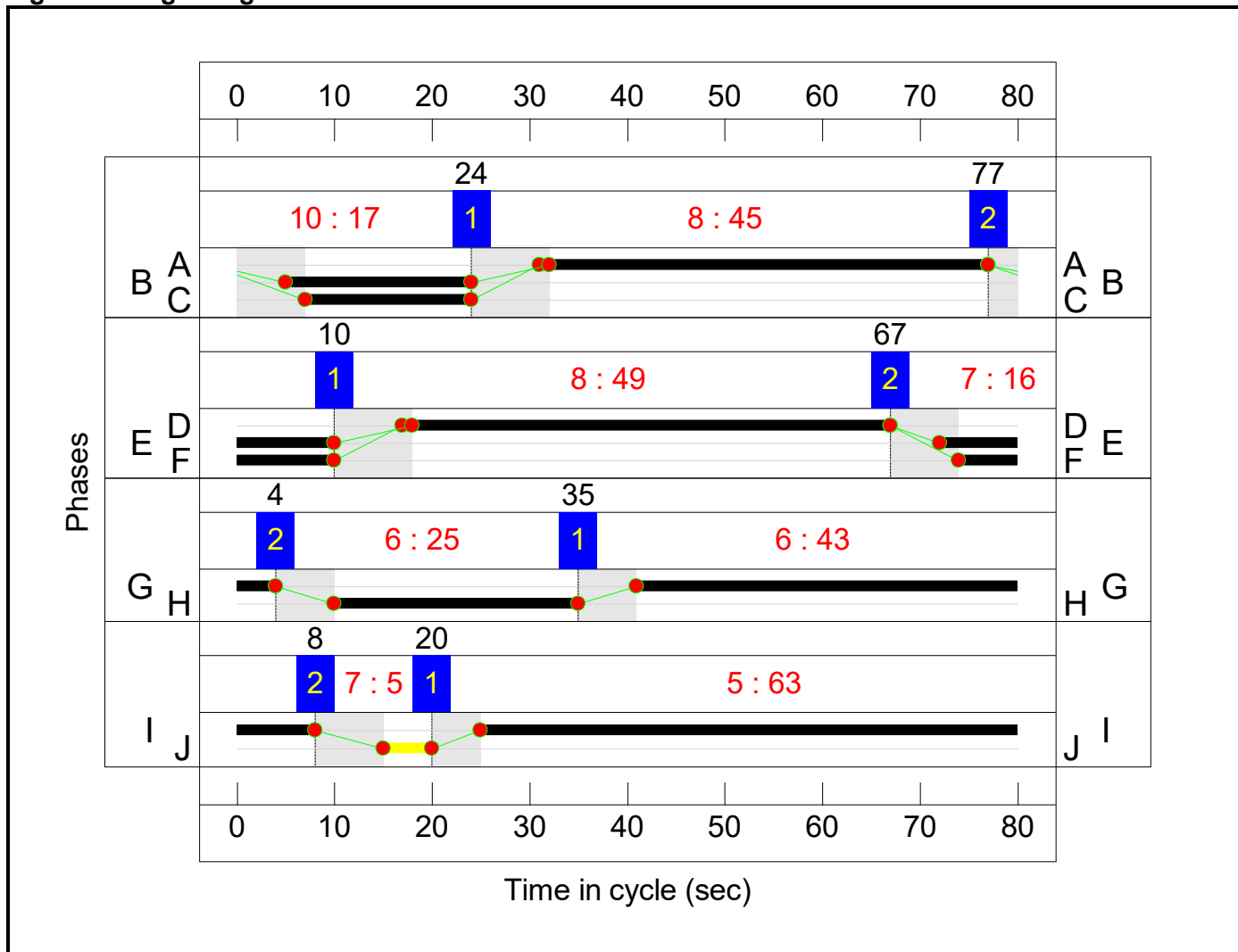

## Network Results

Item	Lane Description	Lane Type	Controller Stream	Position In Filtered Route	Full Phase	Arrow Phase	Num Greens	Total Green (s)	Arrow Green (s)	Demand Flow (pcu)	Sat Flow (pcu/Hr)	Capacity (pcu)	Deg Sat (%)
<b>Network: M1 Junction 15 impact with additional mezzanine</b>	-	-	<b>N/A</b>	-	-		-	-	-	-	-	-	<b>110.6%</b>
<b>M1 Junction 15</b>	-	-	<b>N/A</b>	-	-		-	-	-	-	-	-	<b>110.6%</b>
1/2+1/1	M1 Southbound Offslip Left	U	1:1	N/A	C1:D		1	19	-	779	2120:1980	530+495	76.0 : 76.0%
1/3+1/4	M1 Southbound Offslip Left Ahead	U	1:1	N/A	C1:D C1:C		1	19:21	-	1354	2120:4000	530+1100	85.1 : 82.1%
3/1	Ahead	U	1:2	N/A	C1:I		1	34	-	192	1900	831	22.5%
3/2	Right	U	1:2	N/A	C1:I		1	34	-	198	1900	831	23.8%
3/3	Right	U	1:2	N/A	C1:H		1	33	-	319	1900	808	39.5%
3/4	Right	U	1:2	N/A	C1:H		1	33	-	499	1900	808	61.8%
4/2+4/1	A45 Southbound Left Ahead	U	1:2	N/A	C1:K		1	32	-	991	2120:1980	875+817	56.9 : 60.4%
4/3	A45 Southbound Ahead	U	1:2	N/A	C1:J		1	33	-	944	2120	901	104.8%
4/4+4/5	A45 Southbound Ahead	U	1:2	N/A	C1:J		1	33	-	1910	2120:2120	901+901	106.1 : 105.9%
6/1	M1 Northbound Circulatory Ahead	U	2:1	N/A	C2:A		1	45	-	1263	2120	1219	100.1%
6/2+6/3	M1 Northbound Circulatory Ahead Right	U	2:1	N/A	C2:A		1	45	-	1503	2120:2120	673+828	98.8 : 94.6%
6/4	M1 Northbound Circulatory Right	U	2:1	N/A	C2:A		1	45	-	1031	2120	1219	80.2%
8/1	Saxon Avenue Left Left2	U	1:3	N/A	C1:P		1	7	-	68	1937	194	35.1%
8/2	Saxon Avenue Left	U	1:3	N/A	C1:P		1	7	-	77	2105	210	36.6%
9/2+9/1	M1 Northbound Offslip Left Ahead	U	2:1	N/A	C2:B C2:C		1	19:17	-	914	2120:1980	530+299	110.2 : 110.2%

9/3+9/4	M1 Northbound Offslip Ahead	U	2:1	N/A	C2:B		1	19	-	1172	2120:2120	530+530	110.6 : 110.6%
11/1	Ahead	U	2:2	N/A	C2:D		1	49	-	900	1900	1187	71.6%
11/2	Ahead Right	U	2:2	N/A	C2:D		1	49	-	960	1900	1187	76.7%
12/1	Toucan Crossing Ahead	U	2:4	N/A	C2:I		1	63	-	1224	1995	1596	73.6%
12/2	Toucan Crossing Ahead	U	2:4	N/A	C2:I		1	63	-	1209	1995	1596	72.8%
13/2+13/1	A508 Northampton Rd Ahead	U	2:2	N/A	C2:F		1	16	-	649	1980:1980	421+421	77.2 : 77.0%
13/3	A508 Northampton Rd Ahead	U	2:2	N/A	C2:E		1	18	-	304	2120	503	60.4%
13/4+13/5	A508 Northampton Rd Ahead	U	2:2	N/A	C2:E		1	18	-	665	2120:2120	503+503	65.3 : 66.7%
15/1	Ahead	U	1:1	N/A	C1:A		1	45	-	923	2000	1150	75.4%
15/2	Ahead	U	1:1	N/A	C1:A		1	45	-	915	2000	1150	74.7%
15/3+15/4	Ahead Right	U	1:1	N/A	C1:A C1:B		1	45	-	963	2000:2000	941+436	64.5 : 68.8%
16/1	Right	U	2:3	N/A	C2:H		1	25	-	584	2000	650	81.5%
16/2	Right	U	2:3	N/A	C2:H		1	25	-	586	2000	650	81.5%
16/3	Right	U	2:3	N/A	C2:H		1	25	-	586	2000	650	81.5%
17/1	Ahead	U	2:3	N/A	C2:G		1	43	-	339	2000	1100	30.6%
17/2	Ahead	U	2:3	N/A	C2:G		1	43	-	329	2000	1100	29.9%
17/3	Ahead	U	2:3	N/A	C2:G		1	43	-	377	2000	1100	34.3%
18/1	Ahead	U	1:3	N/A	C1:O		1	60	-	560	2000	1525	36.7%
18/2	Ahead	U	1:3	N/A	C1:O		1	60	-	597	2000	1525	39.1%
19/1	Ahead	U	1:3	N/A	C1:N		1	57	-	1263	2000	1450	84.1%
19/2	Ahead	U	1:3	N/A	C1:N		1	57	-	1455	2120	1537	91.1%
19/3	Ahead	U	1:3	N/A	C1:N		1	57	-	954	2120	1537	58.6%

Item	Arriving (pcu)	Leaving (pcu)	Turners In Gaps (pcu)	Turners When Unopposed (pcu)	Turners In Intergreen (pcu)	Uniform Delay (pcuHr)	Rand + Oversat Delay (pcuHr)	Storage Area Uniform Delay (pcuHr)	Total Delay (pcuHr)	Av. Delay Per PCU (s/pcu)	Max. Back of Uniform Queue (pcu)	Rand + Oversat Queue (pcu)	Mean Max Queue (pcu)
<b>Network: M1 Junction 15 impact with additional mezzanine</b>	-	-	0	0	0	117.7	208.3	0.0	326.0	-	-	-	-
<b>M1 Junction 15</b>	-	-	0	0	0	117.7	208.3	0.0	326.0	-	-	-	-
1/2+1/1	779	779	-	-	-	6.0	1.6	-	7.6 (3.9+3.7)	35.0 (35.0:35.0)	8.3	1.6	9.8
1/3+1/4	1354	1354	-	-	-	10.4	2.4	-	12.8 (4.4+8.4)	34.0 (35.0:33.6)	9.5	2.4	11.9
3/1	187	187	-	-	-	0.3	0.0	-	0.3	5.3	1.3	0.0	1.3
3/2	198	198	-	-	-	1.8	0.0	-	1.8	32.0	4.4	0.0	4.4
3/3	319	319	-	-	-	0.3	0.0	-	0.3	2.9	0.7	0.0	0.7
3/4	499	499	-	-	-	0.2	0.0	-	0.2	1.4	5.0	0.0	5.0
4/2+4/1	991	991	-	-	-	5.0	0.7	-	5.7 (2.9+2.9)	20.8 (20.6:21.0)	8.5	0.7	9.2
4/3	944	901	-	-	-	7.8	29.5	-	37.3	142.1	21.9	29.5	51.4
4/4+4/5	1910	1802	-	-	-	16.5	61.7	-	78.3 (39.7+38.6)	147.5 (149.4:145.6)	22.5	61.7	84.2
6/1	1220	1219	-	-	-	6.8	0.5	-	7.3	21.5	22.2	0.5	22.7
6/2+6/3	1448	1448	-	-	-	6.8	0.0	-	6.8 (3.3+3.6)	17.0 (17.6:16.5)	18.9	0.0	18.9
6/4	978	978	-	-	-	4.9	0.0	-	4.9	18.1	21.1	0.0	21.1
8/1	68	68	-	-	-	0.6	0.3	-	0.9	47.9	1.4	0.3	1.7
8/2	77	77	-	-	-	0.7	0.3	-	1.0	47.1	1.6	0.3	1.9
9/2+9/1	914	860	-	-	-	9.7	47.1	-	56.8 (37.1+19.7)	223.6 (228.8:214.4)	14.2	47.1	61.3
9/3+9/4	1172	1060	-	-	-	14.2	60.8	-	75.0 (37.5+37.5)	230.5 (230.5:230.5)	14.3	60.8	75.1
11/1	851	851	-	-	-	1.5	0.0	-	1.5	6.6	12.3	0.0	12.3
11/2	911	911	-	-	-	1.8	0.0	-	1.8	7.3	4.4	0.0	4.4
12/1	1175	1175	-	-	-	0.3	0.0	-	0.3	0.8	3.4	0.0	3.4



**Scenario 2: '2031 With additional mez - AM' (FG3: '2031 with additional mez - AM', Plan 1: 'Network Control Plan 1')**

**C1 - Eastside Controller**

**Stage Sequence Diagram**

**Stage Stream: 1**

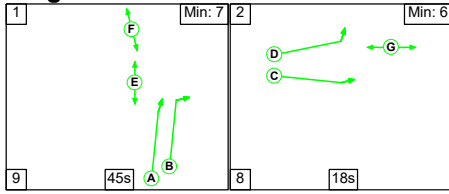

**Stage Stream: 2**

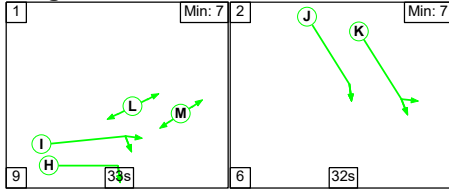

**Stage Stream: 3**

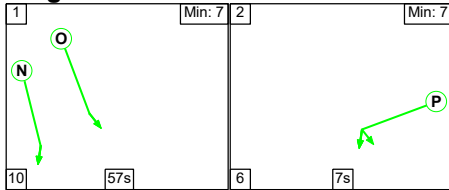

**Stage Timings**

**Stage Stream: 1**

Stage	1	2
Duration	45	18
Change Point	67	41

**Stage Stream: 2**

Stage	1	2
Duration	33	32
Change Point	30	72

**Stage Stream: 3**

Stage	1	2
Duration	57	7
Change Point	47	34

# Signal Timings Diagram

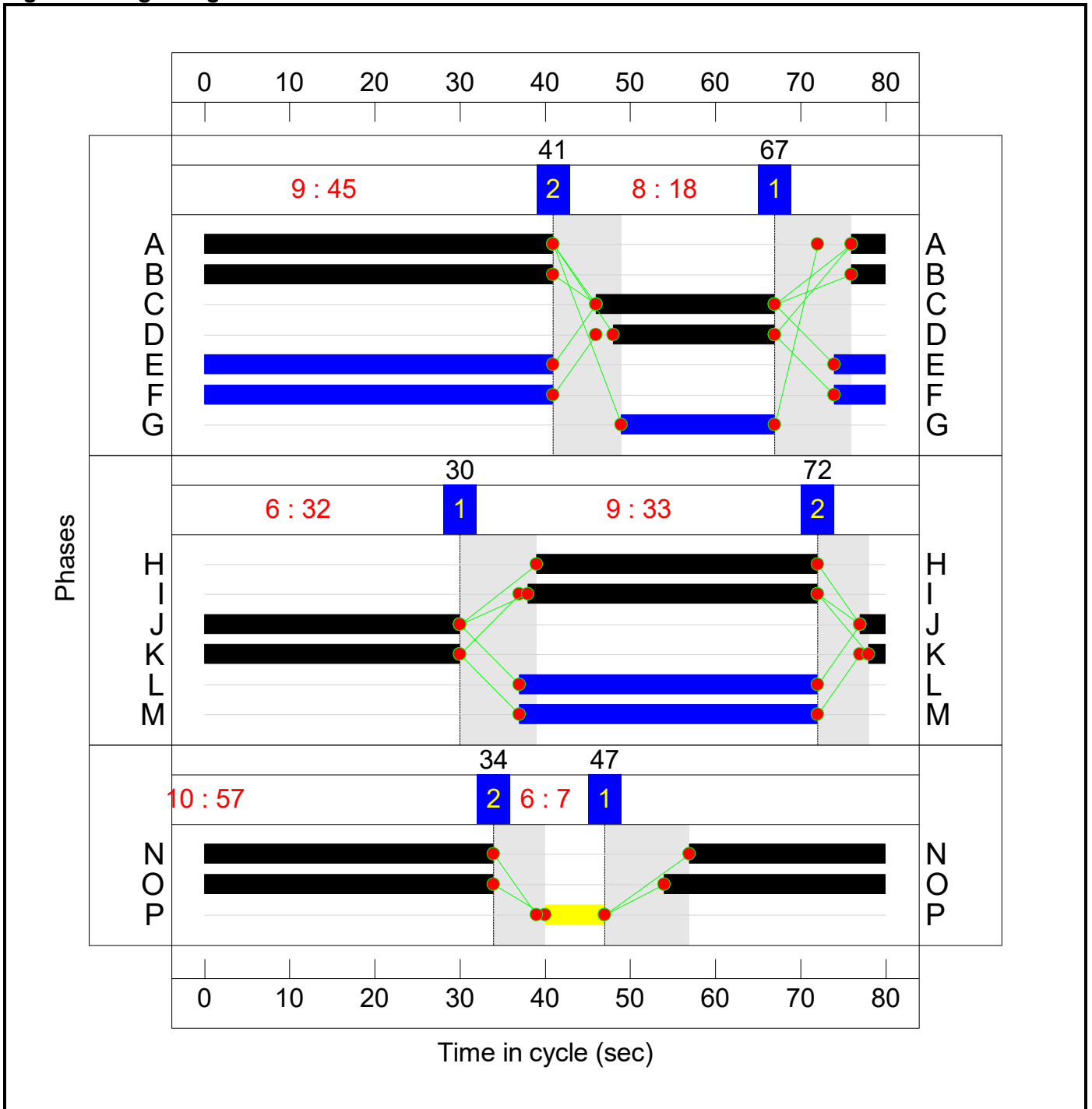

## C2 - Westside Controller Stage Sequence Diagram Stage Stream: 1

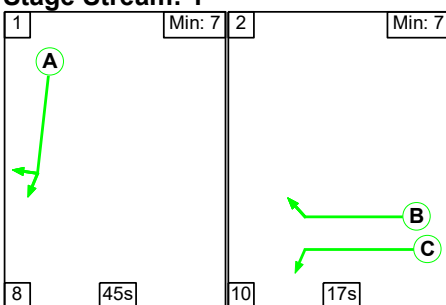

### Stage Stream: 2

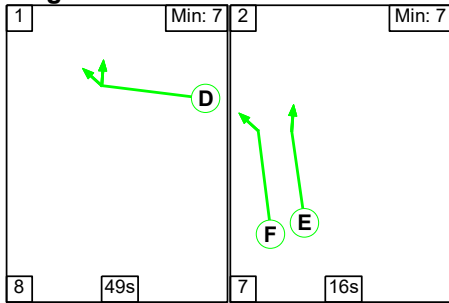

### Stage Stream: 3

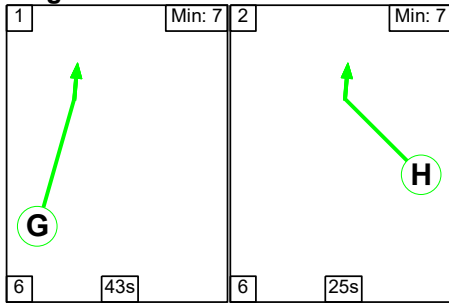

### Stage Stream: 4

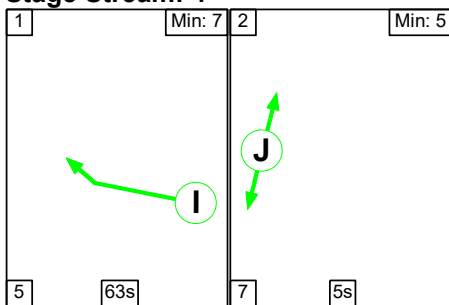

### Stage Timings

#### Stage Stream: 1

Stage	1	2
Duration	45	17
Change Point	24	77

#### Stage Stream: 2

Stage	1	2
Duration	49	16
Change Point	10	67

#### Stage Stream: 3

Stage	1	2
Duration	43	25
Change Point	35	4

#### Stage Stream: 4

Stage	1	2
Duration	63	5
Change Point	20	8

# Signal Timings Diagram

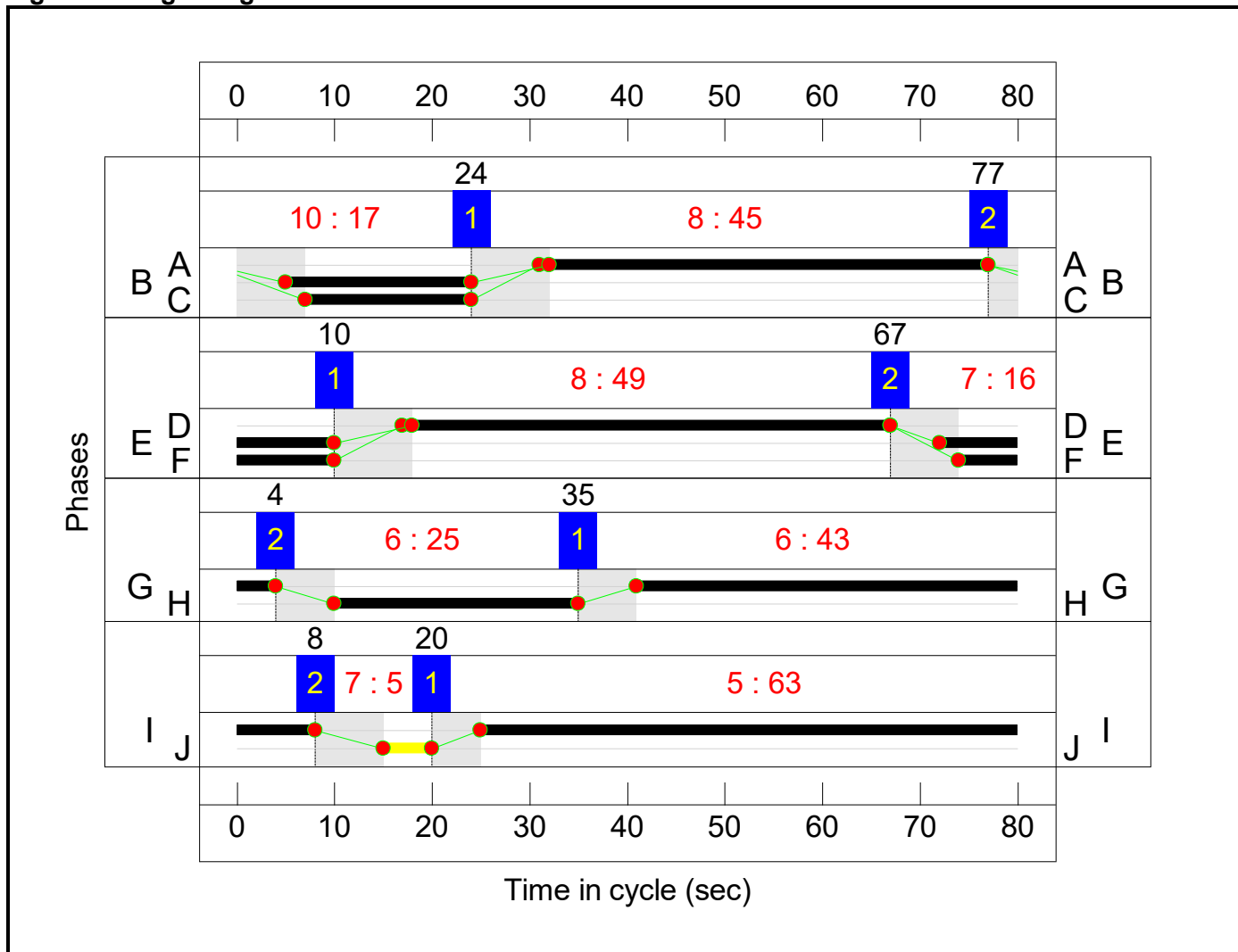

## Network Results

Item	Lane Description	Lane Type	Controller Stream	Position In Filtered Route	Full Phase	Arrow Phase	Num Greens	Total Green (s)	Arrow Green (s)	Demand Flow (pcu)	Sat Flow (pcu/Hr)	Capacity (pcu)	Deg Sat (%)
<b>Network: M1 Junction 15 impact with additional mezzanine</b>	-	-	N/A	-	-		-	-	-	-	-	-	<b>110.6%</b>
<b>M1 Junction 15</b>	-	-	N/A	-	-		-	-	-	-	-	-	<b>110.6%</b>
1/2+1/1	M1 Southbound Offslip Left	U	1:1	N/A	C1:D		1	19	-	785	2120:1980	530+495	76.6 : 76.6%
1/3+1/4	M1 Southbound Offslip Left Ahead	U	1:1	N/A	C1:D C1:C		1	19:21	-	1371	2120:4000	530+1100	84.0 : 84.2%
3/1	Ahead	U	1:2	N/A	C1:I		1	34	-	192	1900	831	22.5%
3/2	Right	U	1:2	N/A	C1:I		1	34	-	208	1900	831	25.0%
3/3	Right	U	1:2	N/A	C1:H		1	33	-	319	1900	808	39.5%
3/4	Right	U	1:2	N/A	C1:H		1	33	-	522	1900	808	64.6%
4/2+4/1	A45 Southbound Left Ahead	U	1:2	N/A	C1:K		1	32	-	991	2120:1980	875+817	56.9 : 60.4%
4/3	A45 Southbound Ahead	U	1:2	N/A	C1:J		1	33	-	956	2120	901	106.1%
4/4+4/5	A45 Southbound Ahead	U	1:2	N/A	C1:J		1	33	-	1935	2120:2120	901+901	107.4 : 107.3%
6/1	M1 Northbound Circulatory Ahead	U	2:1	N/A	C2:A		1	45	-	1275	2120	1219	100.1%
6/2+6/3	M1 Northbound Circulatory Ahead Right	U	2:1	N/A	C2:A		1	45	-	1533	2120:2120	720+809	98.5 : 93.6%
6/4	M1 Northbound Circulatory Right	U	2:1	N/A	C2:A		1	45	-	1049	2120	1219	80.6%
8/1	Saxon Avenue Left Left2	U	1:3	N/A	C1:P		1	7	-	63	1934	193	32.6%
8/2	Saxon Avenue Left	U	1:3	N/A	C1:P		1	7	-	82	2105	210	39.0%
9/2+9/1	M1 Northbound Offslip Left Ahead	U	2:1	N/A	C2:B C2:C		1	19:17	-	941	2120:1980	530+330	110.2 : 108.2%

9/3+9/4	M1 Northbound Offslip Ahead	U	2:1	N/A	C2:B		1	19	-	1172	2120:2120	530+530	110.6 : 110.6%
11/1	Ahead	U	2:2	N/A	C2:D		1	49	-	913	1900	1187	71.8%
11/2	Ahead Right	U	2:2	N/A	C2:D		1	49	-	947	1900	1187	74.7%
12/1	Toucan Crossing Ahead	U	2:4	N/A	C2:I		1	63	-	1242	1995	1596	74.0%
12/2	Toucan Crossing Ahead	U	2:4	N/A	C2:I		1	63	-	1200	1995	1596	71.6%
13/2+13/1	A508 Northampton Rd Ahead	U	2:2	N/A	C2:F		1	16	-	658	1980:1980	421+421	78.2 : 78.2%
13/3	A508 Northampton Rd Ahead	U	2:2	N/A	C2:E		1	18	-	311	2120	503	61.8%
13/4+13/5	A508 Northampton Rd Ahead	U	2:2	N/A	C2:E		1	18	-	683	2120:2120	503+503	67.1 : 68.5%
15/1	Ahead	U	1:1	N/A	C1:A		1	45	-	930	2000	1150	76.0%
15/2	Ahead	U	1:1	N/A	C1:A		1	45	-	924	2000	1150	75.5%
15/3+15/4	Ahead Right	U	1:1	N/A	C1:A C1:B		1	45	-	972	2000:2000	936+449	64.7 : 69.1%
16/1	Right	U	2:3	N/A	C2:H		1	25	-	584	2000	650	81.5%
16/2	Right	U	2:3	N/A	C2:H		1	25	-	586	2000	650	81.5%
16/3	Right	U	2:3	N/A	C2:H		1	25	-	586	2000	650	81.5%
17/1	Ahead	U	2:3	N/A	C2:G		1	43	-	346	2000	1100	31.2%
17/2	Ahead	U	2:3	N/A	C2:G		1	43	-	338	2000	1100	30.7%
17/3	Ahead	U	2:3	N/A	C2:G		1	43	-	386	2000	1100	35.1%
18/1	Ahead	U	1:3	N/A	C1:O		1	60	-	565	2000	1525	37.0%
18/2	Ahead	U	1:3	N/A	C1:O		1	60	-	602	2000	1525	39.5%
19/1	Ahead	U	1:3	N/A	C1:N		1	57	-	1275	2000	1450	84.1%
19/2	Ahead	U	1:3	N/A	C1:N		1	57	-	1490	2120	1537	92.6%
19/3	Ahead	U	1:3	N/A	C1:N		1	57	-	967	2120	1537	58.6%

Item	Arriving (pcu)	Leaving (pcu)	Turners In Gaps (pcu)	Turners When Unopposed (pcu)	Turners In Intergreen (pcu)	Uniform Delay (pcuHr)	Rand + Oversat Delay (pcuHr)	Storage Area Uniform Delay (pcuHr)	Total Delay (pcuHr)	Av. Delay Per PCU (s/pcu)	Max. Back of Uniform Queue (pcu)	Rand + Oversat Queue (pcu)	Mean Max Queue (pcu)
<b>Network: M1 Junction 15 impact with additional mezzanine</b>	-	-	0	0	0	120.8	223.6	0.0	344.4	-	-	-	-
<b>M1 Junction 15</b>	-	-	0	0	0	120.8	223.6	0.0	344.4	-	-	-	-
1/2+1/1	785	785	-	-	-	6.1	1.6	-	7.7 (4.0+3.7)	35.2 (35.2:35.2)	8.3	1.6	10.0
1/3+1/4	1371	1371	-	-	-	10.6	2.6	-	13.2 (4.4+8.8)	34.5 (35.3:34.2)	9.6	2.6	12.2
3/1	187	187	-	-	-	0.3	0.0	-	0.3	5.3	1.3	0.0	1.3
3/2	208	208	-	-	-	1.9	0.0	-	1.9	32.3	4.6	0.0	4.6
3/3	319	319	-	-	-	0.3	0.0	-	0.3	2.9	0.7	0.0	0.7
3/4	522	522	-	-	-	0.2	0.0	-	0.2	1.6	6.2	0.0	6.2
4/2+4/1	991	991	-	-	-	5.0	0.7	-	5.7 (2.9+2.9)	20.8 (20.6:21.0)	8.5	0.7	9.2
4/3	956	901	-	-	-	8.3	34.4	-	42.8	161.0	22.5	34.4	56.9
4/4+4/5	1935	1802	-	-	-	17.7	73.1	-	90.8 (45.7+45.1)	169.0 (169.9:168.0)	23.0	73.1	96.1
6/1	1220	1219	-	-	-	6.8	0.5	-	7.3	21.5	22.2	0.5	22.7
6/2+6/3	1466	1466	-	-	-	7.2	0.0	-	7.2 (3.6+3.6)	17.7 (18.4:17.0)	19.5	0.0	19.5
6/4	983	983	-	-	-	4.9	0.0	-	4.9	18.1	21.8	0.0	21.8
8/1	63	63	-	-	-	0.6	0.2	-	0.8	47.3	1.3	0.2	1.5
8/2	82	82	-	-	-	0.8	0.3	-	1.1	47.7	1.7	0.3	2.0
9/2+9/1	941	887	-	-	-	9.9	45.7	-	55.6 (37.2+18.4)	212.7 (229.4:185.4)	14.2	45.7	59.9
9/3+9/4	1172	1060	-	-	-	14.2	60.8	-	75.0 (37.5+37.5)	230.5 (230.5:230.5)	14.3	60.8	75.1
11/1	852	852	-	-	-	1.5	0.0	-	1.5	6.2	4.4	0.0	4.4
11/2	888	888	-	-	-	1.5	0.0	-	1.5	6.0	3.9	0.0	3.9
12/1	1181	1181	-	-	-	0.3	0.0	-	0.3	0.9	3.5	0.0	3.5

12/2	1143	1143	-	-	-	0.2	0.0	-	0.2	0.8	3.3	0.0	3.3
13/2+13/1	658	658	-	-	-	5.4	1.8	-	7.2 (3.6+3.6)	39.4 (39.4:39.4)	6.9	1.8	8.6
13/3	311	311	-	-	-	2.4	0.8	-	3.2	36.5	6.1	0.8	6.9
13/4+13/5	683	683	-	-	-	5.3	1.0	-	6.3 (3.1+3.2)	33.2 (33.2:33.3)	6.9	1.0	7.9
15/1	874	874	-	-	-	0.9	0.0	-	0.9	3.9	3.2	0.0	3.2
15/2	868	868	-	-	-	1.0	0.0	-	1.0	4.1	3.1	0.0	3.1
15/3+15/4	916	916	-	-	-	1.3	0.0	-	1.3 (0.5+0.8)	4.9 (2.8:9.1)	2.5	0.0	2.5
16/1	530	530	-	-	-	0.1	0.0	-	0.1	0.6	0.7	0.0	0.7
16/2	530	530	-	-	-	0.1	0.0	-	0.1	0.6	0.7	0.0	0.7
16/3	530	530	-	-	-	0.1	0.0	-	0.1	0.6	0.7	0.0	0.7
17/1	344	344	-	-	-	1.1	0.0	-	1.1	11.8	2.6	0.0	2.6
17/2	338	338	-	-	-	1.4	0.0	-	1.4	14.8	3.1	0.0	3.1
17/3	386	386	-	-	-	1.7	0.0	-	1.7	15.7	4.1	0.0	4.1
18/1	565	565	-	-	-	0.3	0.0	-	0.3	1.7	2.4	0.0	2.4
18/2	602	602	-	-	-	0.3	0.0	-	0.3	1.8	2.4	0.0	2.4
19/1	1220	1220	-	-	-	1.0	0.0	-	1.0	2.8	5.1	0.0	5.1
19/2	1423	1423	-	-	-	0.2	0.0	-	0.2	0.5	0.6	0.0	0.6
19/3	901	901	-	-	-	0.2	0.0	-	0.2	0.6	0.6	0.0	0.6

C1 - Eastside Controller	Stream: 1 PRC for Signalled Lanes (%)	6.9	Total Delay for Signalled Lanes (pcuHr):	24.03	Cycle Time (s):	80
C1 - Eastside Controller	Stream: 2 PRC for Signalled Lanes (%)	-19.4	Total Delay for Signalled Lanes (pcuHr):	141.93	Cycle Time (s):	80
C1 - Eastside Controller	Stream: 3 PRC for Signalled Lanes (%)	-2.9	Total Delay for Signalled Lanes (pcuHr):	3.79	Cycle Time (s):	80
C2 - Westside Controller	Stream: 1 PRC for Signalled Lanes (%)	-22.9	Total Delay for Signalled Lanes (pcuHr):	150.07	Cycle Time (s):	80
C2 - Westside Controller	Stream: 2 PRC for Signalled Lanes (%)	15.1	Total Delay for Signalled Lanes (pcuHr):	19.62	Cycle Time (s):	80
C2 - Westside Controller	Stream: 3 PRC for Signalled Lanes (%)	10.4	Total Delay for Signalled Lanes (pcuHr):	4.47	Cycle Time (s):	80
C2 - Westside Controller	Stream: 4 PRC for Signalled Lanes (%)	21.6	Total Delay for Signalled Lanes (pcuHr):	0.52	Cycle Time (s):	80
	PRC Over All Lanes (%)	-22.9	Total Delay Over All Lanes(pcuHr):	344.43		

**Scenario 3: '2031 Background - PM'** (FG2: '2031 background - PM', Plan 1: 'Network Control Plan 1')

**C1 - Eastside Controller**

**Stage Sequence Diagram**

**Stage Stream: 1**

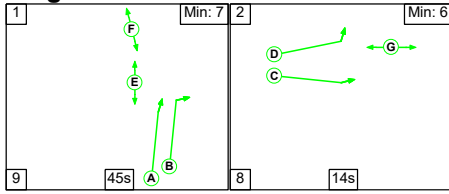

**Stage Stream: 2**

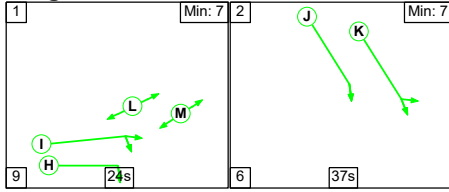

**Stage Stream: 3**

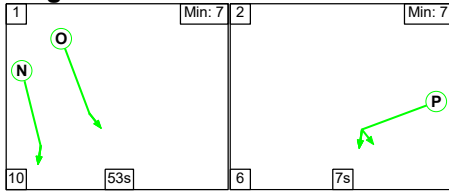

**Stage Timings**

**Stage Stream: 1**

Stage	1	2
Duration	45	14
Change Point	4	58

**Stage Stream: 2**

Stage	1	2
Duration	24	37
Change Point	47	4

**Stage Stream: 3**

Stage	1	2
Duration	53	7
Change Point	58	45

# Signal Timings Diagram

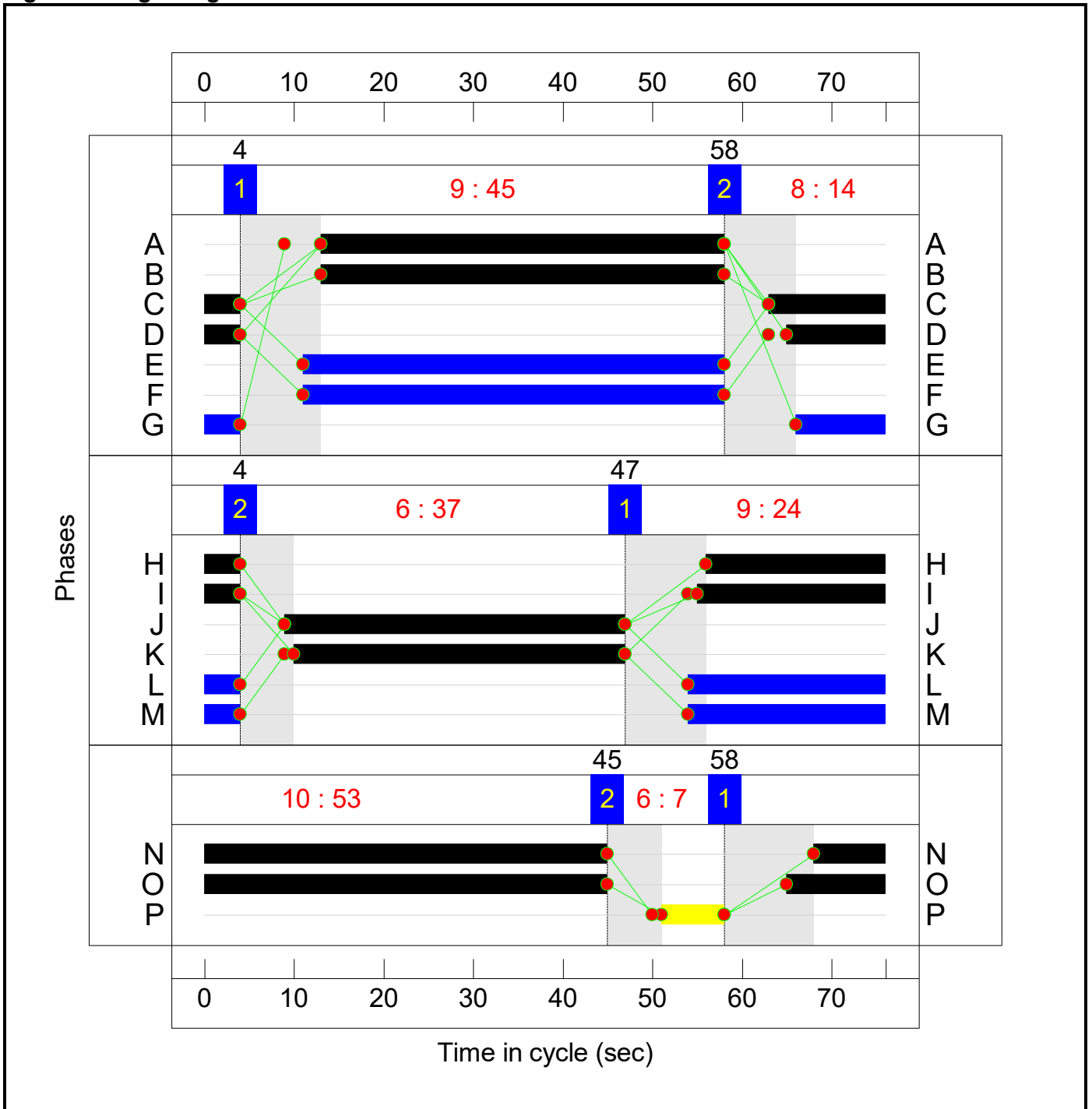

## C2 - Westside Controller Stage Sequence Diagram Stage Stream: 1

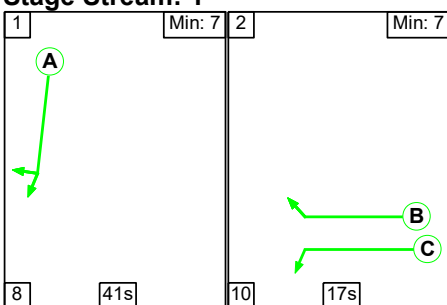

### Stage Stream: 2

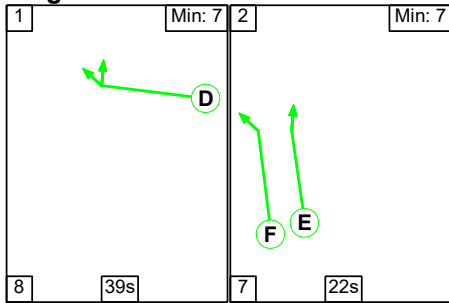

### Stage Stream: 3

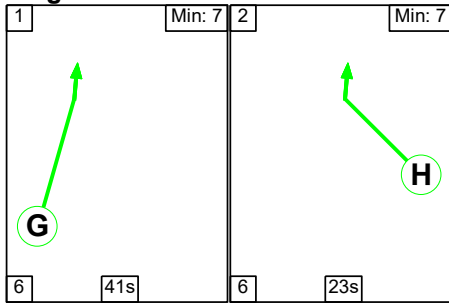

### Stage Stream: 4

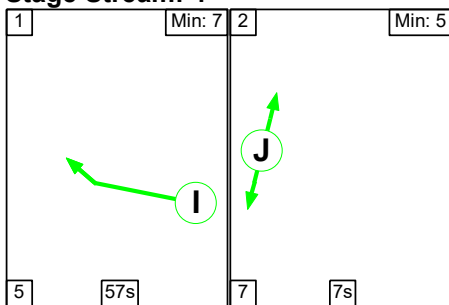

### Stage Timings

#### Stage Stream: 1

Stage	1	2
Duration	41	17
Change Point	24	73

#### Stage Stream: 2

Stage	1	2
Duration	39	22
Change Point	10	57

#### Stage Stream: 3

Stage	1	2
Duration	41	23
Change Point	33	4

#### Stage Stream: 4

Stage	1	2
Duration	57	7
Change Point	13	75

# Signal Timings Diagram

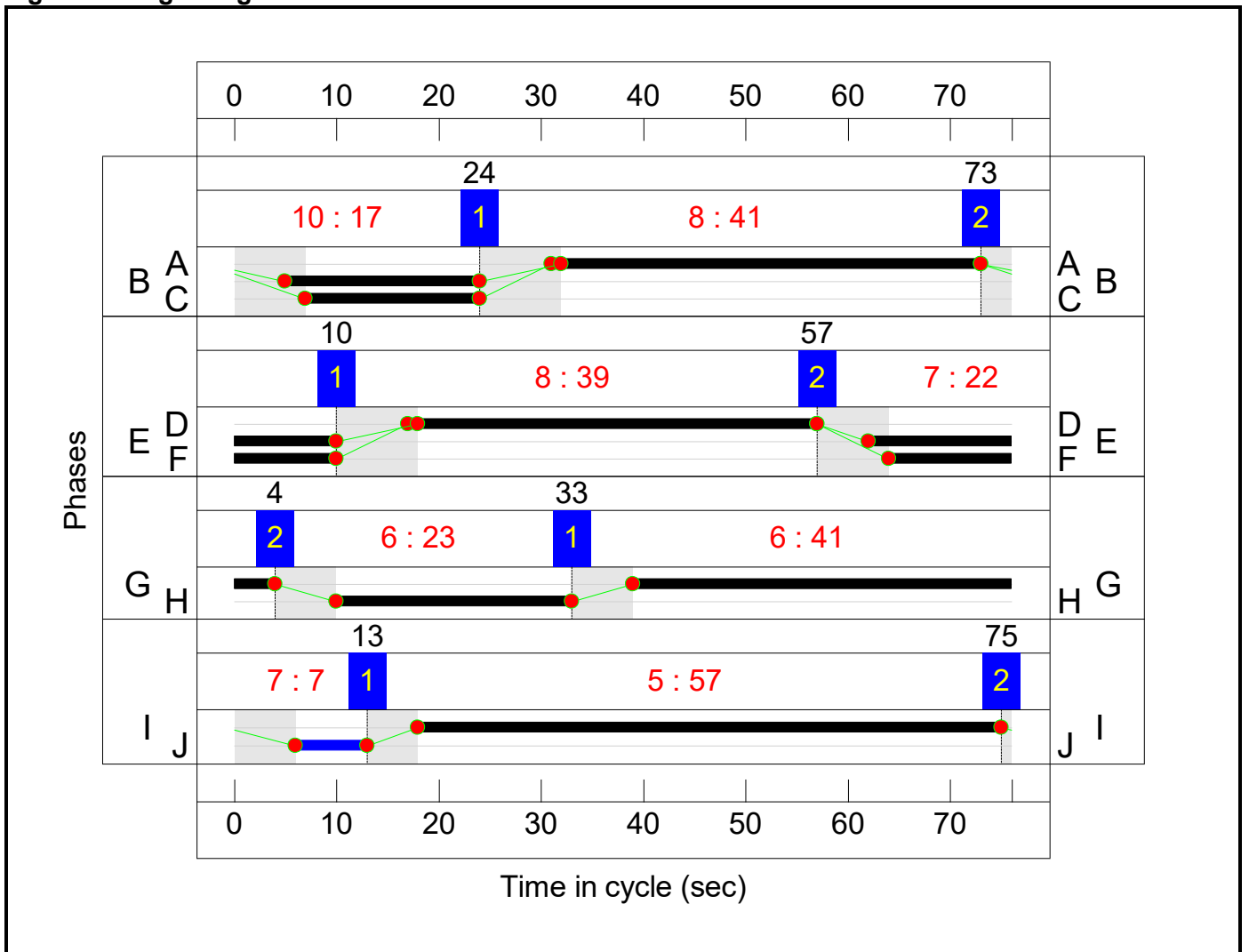

## Network Results

Item	Lane Description	Lane Type	Controller Stream	Position In Filtered Route	Full Phase	Arrow Phase	Num Greens	Total Green (s)	Arrow Green (s)	Demand Flow (pcu)	Sat Flow (pcu/Hr)	Capacity (pcu)	Deg Sat (%)
<b>Network: M1 Junction 15 impact with additional mezzanine</b>	-	-	<b>N/A</b>	-	-		-	-	-	-	-	-	<b>100.4%</b>
<b>M1 Junction 15</b>	-	-	<b>N/A</b>	-	-		-	-	-	-	-	-	<b>100.4%</b>
1/2+1/1	M1 Southbound Offslip Left	U	1:1	N/A	C1:D		1	15	-	604	2120:1980	446+417	69.9 : 70.1%
1/3+1/4	M1 Southbound Offslip Left Ahead	U	1:1	N/A	C1:D C1:C		1	15:17	-	1065	2120:4000	446+947	90.3 : 69.9%
3/1	Ahead	U	1:2	N/A	C1:I		1	25	-	137	1900	650	21.1%
3/2	Right	U	1:2	N/A	C1:I		1	25	-	199	1900	650	30.6%
3/3	Right	U	1:2	N/A	C1:H		1	24	-	261	1900	625	41.8%
3/4	Right	U	1:2	N/A	C1:H		1	24	-	352	1900	625	56.3%
4/2+4/1	A45 Southbound Left Ahead	U	1:2	N/A	C1:K		1	37	-	1073	2120:1980	1029+990	52.4 : 53.9%
4/3	A45 Southbound Ahead	U	1:2	N/A	C1:J		1	38	-	866	2120	1088	79.6%
4/4+4/5	A45 Southbound Ahead	U	1:2	N/A	C1:J		1	38	-	1729	2120:2120	832+1088	81.9 : 96.2%
6/1	M1 Northbound Circulatory Ahead	U	2:1	N/A	C2:A		1	41	-	1127	2120	1172	96.2%
6/2+6/3	M1 Northbound Circulatory Ahead Right	U	2:1	N/A	C2:A		1	41	-	1053	2120:2120	900+448	78.1 : 78.1%
6/4	M1 Northbound Circulatory Right	U	2:1	N/A	C2:A		1	41	-	1176	2120	1172	100.4%
8/1	Saxon Avenue Left Left2	U	1:3	N/A	C1:P		1	7	-	140	1884	198	70.6%
8/2	Saxon Avenue Left	U	1:3	N/A	C1:P		1	7	-	129	2105	222	58.2%
9/2+9/1	M1 Northbound Offslip Left Ahead	U	2:1	N/A	C2:B C2:C		1	19:17	-	698	2120:1980	558+232	88.4 : 88.4%

9/3+9/4	M1 Northbound Offslip Ahead	U	2:1	N/A	C2:B		1	19	-	1035	2120:2120	558+558	85.1 : 100.4%
11/1	Ahead	U	2:2	N/A	C2:D		1	39	-	656	1900	1000	65.3%
11/2	Ahead Right	U	2:2	N/A	C2:D		1	39	-	870	1900	1000	86.9%
12/1	Toucan Crossing Ahead	U	2:4	N/A	C2:I		1	57	-	1010	1995	1523	66.1%
12/2	Toucan Crossing Ahead	U	2:4	N/A	C2:I		1	57	-	1078	1995	1523	70.8%
13/2+13/1	A508 Northampton Rd Ahead	U	2:2	N/A	C2:F		1	22	-	709	1980:1980	539+537	65.9 : 65.9%
13/3	A508 Northampton Rd Ahead	U	2:2	N/A	C2:E		1	24	-	516	2120	697	74.0%
13/4+13/5	A508 Northampton Rd Ahead	U	2:2	N/A	C2:E		1	24	-	1186	2120:2120	697+697	81.9 : 88.2%
15/1	Ahead	U	1:1	N/A	C1:A		1	45	-	1139	2000	1211	94.1%
15/2	Ahead	U	1:1	N/A	C1:A		1	45	-	1062	2000	1211	87.7%
15/3+15/4	Ahead Right	U	1:1	N/A	C1:A C1:B		1	45	-	1176	2000:2000	1043+337	85.0 : 85.2%
16/1	Right	U	2:3	N/A	C2:H		1	23	-	493	2000	632	78.1%
16/2	Right	U	2:3	N/A	C2:H		1	23	-	475	2000	632	75.2%
16/3	Right	U	2:3	N/A	C2:H		1	23	-	560	2000	632	88.3%
17/1	Ahead	U	2:3	N/A	C2:G		1	41	-	646	2000	1105	58.4%
17/2	Ahead	U	2:3	N/A	C2:G		1	41	-	587	2000	1105	53.1%
17/3	Ahead	U	2:3	N/A	C2:G		1	41	-	616	2000	1105	55.7%
18/1	Ahead	U	1:3	N/A	C1:O		1	56	-	555	2000	1500	37.0%
18/2	Ahead	U	1:3	N/A	C1:O		1	56	-	629	2000	1500	41.9%
19/1	Ahead	U	1:3	N/A	C1:N		1	53	-	1127	2000	1421	79.3%
19/2	Ahead	U	1:3	N/A	C1:N		1	53	-	1034	2120	1506	68.6%
19/3	Ahead	U	1:3	N/A	C1:N		1	53	-	1047	2120	1506	69.5%

Item	Arriving (pcu)	Leaving (pcu)	Turners In Gaps (pcu)	Turners When Unopposed (pcu)	Turners In Intergreen (pcu)	Uniform Delay (pcuHr)	Rand + Oversat Delay (pcuHr)	Storage Area Uniform Delay (pcuHr)	Total Delay (pcuHr)	Av. Delay Per PCU (s/pcu)	Max. Back of Uniform Queue (pcu)	Rand + Oversat Queue (pcu)	Mean Max Queue (pcu)
<b>Network: M1 Junction 15 impact with additional mezzanine</b>	-	-	0	0	0	104.1	29.0	0.0	133.0	-	-	-	-
<b>M1 Junction 15</b>	-	-	0	0	0	104.1	29.0	0.0	133.0	-	-	-	-
1/2+1/1	604	604	-	-	-	4.7	1.2	-	5.8 (3.0+2.8)	34.7 (34.7:34.7)	6.1	1.2	7.2
1/3+1/4	1065	1065	-	-	-	8.2	1.6	-	9.8 (3.9+5.9)	33.0 (34.7:32.0)	8.3	1.6	9.9
3/1	137	137	-	-	-	0.3	0.0	-	0.3	8.1	0.9	0.0	0.9
3/2	199	199	-	-	-	1.3	0.0	-	1.3	23.3	4.1	0.0	4.1
3/3	261	261	-	-	-	0.5	0.0	-	0.5	6.9	1.2	0.0	1.2
3/4	352	352	-	-	-	0.4	0.0	-	0.4	4.4	0.7	0.0	0.7
4/2+4/1	1073	1073	-	-	-	3.8	0.6	-	4.4 (2.2+2.2)	14.8 (14.6:14.9)	7.7	0.6	8.3
4/3	866	866	-	-	-	3.7	1.9	-	5.6	23.2	14.9	1.9	16.8
4/4+4/5	1729	1729	-	-	-	7.7	4.3	-	12.0 (4.2+7.8)	25.0 (22.3:26.8)	21.2	4.3	25.6
6/1	1127	1127	-	-	-	6.6	0.0	-	6.6	21.0	23.8	0.0	23.8
6/2+6/3	1053	1053	-	-	-	6.4	0.0	-	6.4 (4.4+2.0)	21.8 (22.3:20.8)	21.5	0.0	21.5
6/4	1176	1172	-	-	-	4.8	2.2	-	7.0	21.5	25.0	2.2	27.2
8/1	140	140	-	-	-	1.3	1.2	-	2.4	62.6	2.8	1.2	4.0
8/2	129	129	-	-	-	1.2	0.7	-	1.8	51.6	2.6	0.7	3.3
9/2+9/1	698	698	-	-	-	5.1	3.5	-	8.6 (6.2+2.4)	44.4 (45.1:42.9)	9.9	3.5	13.4
9/3+9/4	1035	1033	-	-	-	7.9	6.7	-	14.6 (6.1+8.5)	50.8 (46.1:54.8)	11.9	6.7	18.5
11/1	653	653	-	-	-	3.9	0.0	-	3.9	21.6	8.8	0.0	8.8
11/2	869	869	-	-	-	4.2	0.0	-	4.2	17.2	9.1	0.0	9.1
12/1	1007	1007	-	-	-	0.5	0.0	-	0.5	1.9	2.5	0.0	2.5

12/2	1078	1078	-	-	-	0.4	0.0	-	0.4	1.5	2.4	0.0	2.4
13/2+13/1	709	709	-	-	-	4.4	1.0	-	5.4 (2.7+2.7)	27.4 (27.4:27.4)	6.3	1.0	7.3
13/3	516	516	-	-	-	3.2	1.4	-	4.6	32.4	9.6	1.4	11.0
13/4+13/5	1186	1186	-	-	-	7.8	2.8	-	10.6 (5.0+5.6)	32.2 (31.8:32.5)	12.1	2.8	14.9
15/1	1139	1139	-	-	-	3.1	0.0	-	3.1	9.7	19.0	0.0	19.0
15/2	1061	1061	-	-	-	2.4	0.0	-	2.4	8.1	17.8	0.0	17.8
15/3+15/4	1174	1174	-	-	-	1.2	0.0	-	1.2 (0.8+0.4)	3.7 (3.3:5.0)	16.1	0.0	16.1
16/1	493	493	-	-	-	0.1	0.0	-	0.1	0.5	0.6	0.0	0.6
16/2	475	475	-	-	-	0.1	0.0	-	0.1	0.5	0.5	0.0	0.5
16/3	558	558	-	-	-	0.1	0.0	-	0.1	0.6	0.7	0.0	0.7
17/1	646	646	-	-	-	1.7	0.0	-	1.7	9.4	4.8	0.0	4.8
17/2	586	586	-	-	-	2.0	0.0	-	2.0	12.4	4.6	0.0	4.6
17/3	616	616	-	-	-	2.4	0.0	-	2.4	14.2	5.2	0.0	5.2
18/1	555	555	-	-	-	0.3	0.0	-	0.3	1.9	3.2	0.0	3.2
18/2	629	629	-	-	-	0.4	0.0	-	0.4	2.0	2.9	0.0	2.9
19/1	1127	1127	-	-	-	0.8	0.0	-	0.8	2.4	3.0	0.0	3.0
19/2	1034	1034	-	-	-	0.4	0.0	-	0.4	1.4	1.9	0.0	1.9
19/3	1047	1047	-	-	-	0.9	0.0	-	0.9	3.2	3.3	0.0	3.3

C1 - Eastside Controller	Stream: 1 PRC for Signalled Lanes (%)	-4.5	Total Delay for Signalled Lanes (pcuHr)	22.24	Cycle Time (s)	76
C1 - Eastside Controller	Stream: 2 PRC for Signalled Lanes (%)	-6.9	Total Delay for Signalled Lanes (pcuHr)	24.53	Cycle Time (s)	76
C1 - Eastside Controller	Stream: 3 PRC for Signalled Lanes (%)	13.5	Total Delay for Signalled Lanes (pcuHr)	7.03	Cycle Time (s)	76
C2 - Westside Controller	Stream: 1 PRC for Signalled Lanes (%)	-11.5	Total Delay for Signalled Lanes (pcuHr)	43.20	Cycle Time (s)	76
C2 - Westside Controller	Stream: 2 PRC for Signalled Lanes (%)	2.1	Total Delay for Signalled Lanes (pcuHr)	28.71	Cycle Time (s)	76
C2 - Westside Controller	Stream: 3 PRC for Signalled Lanes (%)	1.9	Total Delay for Signalled Lanes (pcuHr)	6.35	Cycle Time (s)	76
C2 - Westside Controller	Stream: 4 PRC for Signalled Lanes (%)	27.1	Total Delay for Signalled Lanes (pcuHr)	0.98	Cycle Time (s)	76
	PRC Over All Lanes (%)	-11.5	Total Delay Over All Lanes (pcuHr)	133.03		

**Scenario 4: '2031 With additional mez - PM ' (FG4: '2031 with additional mez - PM', Plan 1: 'Network Control Plan 1')**

**C1 - Eastside Controller  
Stage Sequence Diagram**

**Stage Stream: 1**

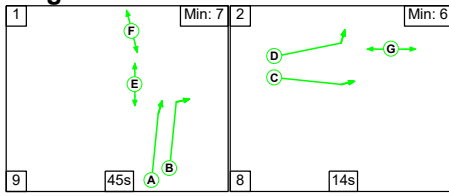

**Stage Stream: 2**

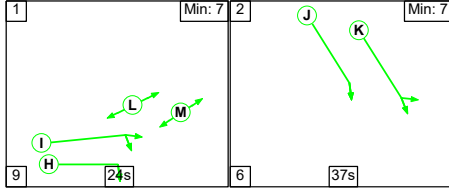

**Stage Stream: 3**

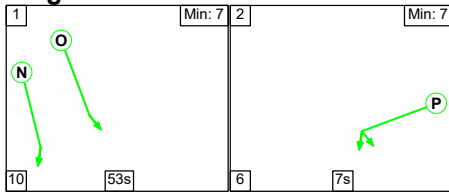

**Stage Timings**

**Stage Stream: 1**

Stage	1	2
Duration	45	14
Change Point	4	58

**Stage Stream: 2**

Stage	1	2
Duration	24	37
Change Point	47	4

**Stage Stream: 3**

Stage	1	2
Duration	53	7
Change Point	58	45

# Signal Timings Diagram

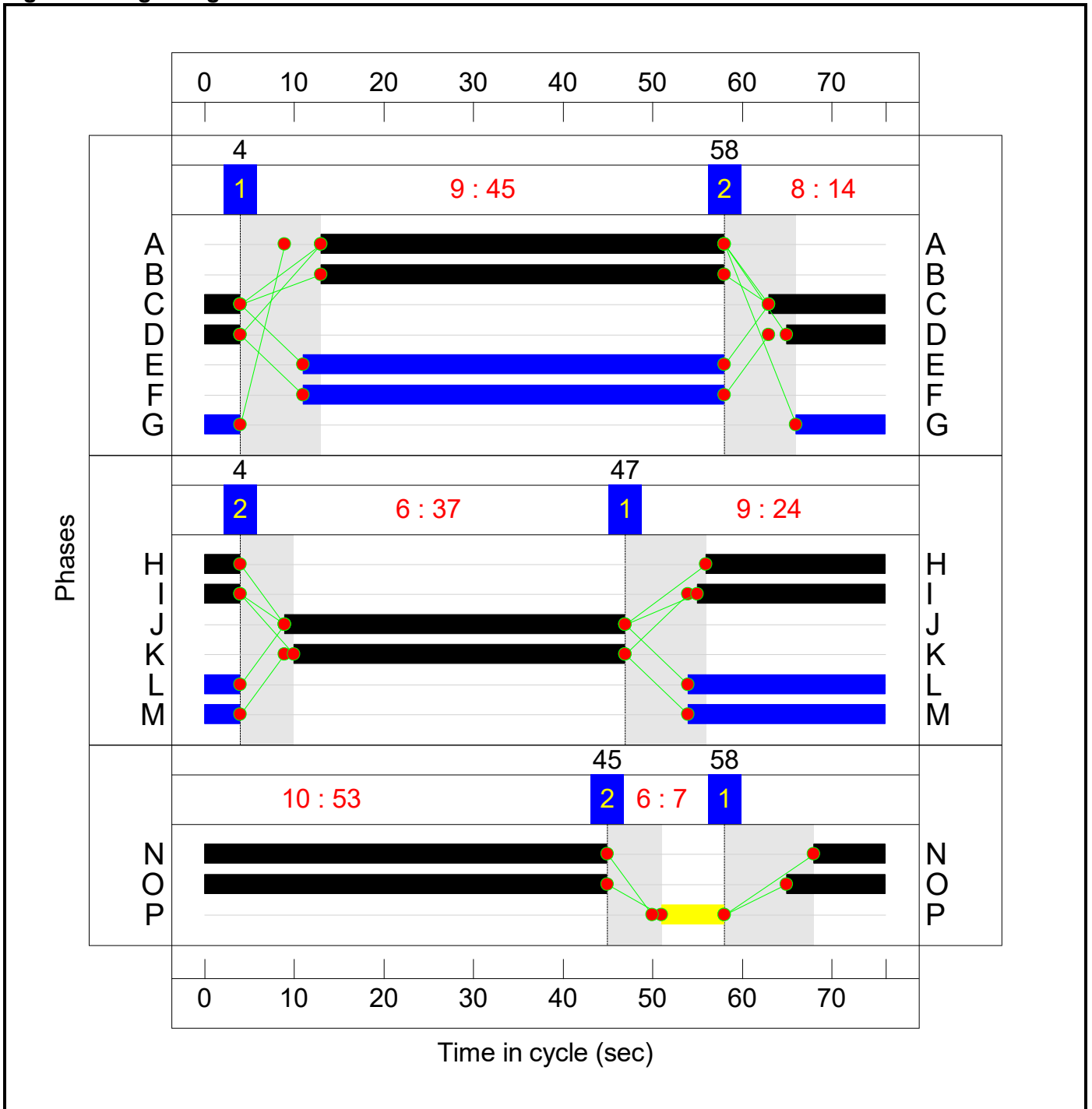

## C2 - Westside Controller Stage Sequence Diagram Stage Stream: 1

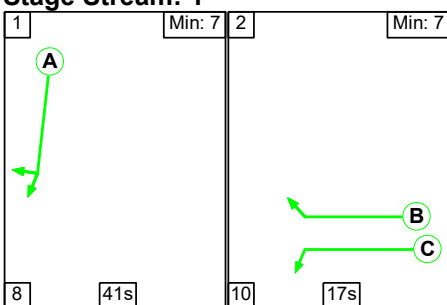

### Stage Stream: 2

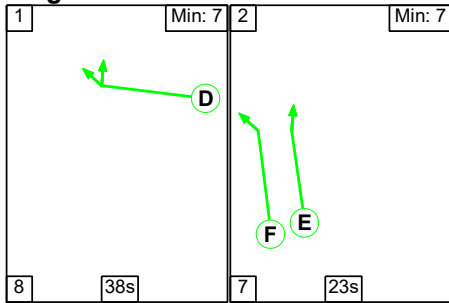

### Stage Stream: 3

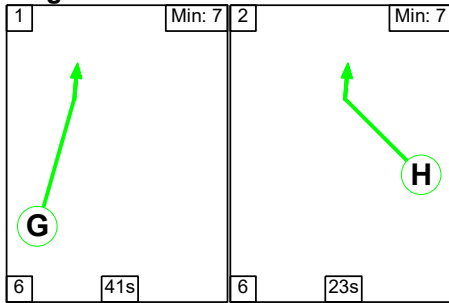

### Stage Stream: 4

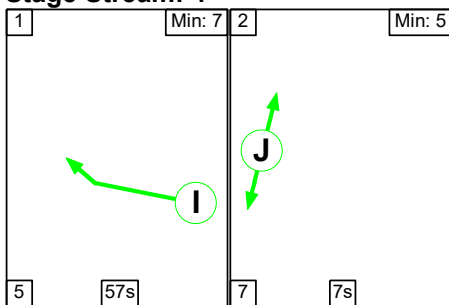

### Stage Timings

#### Stage Stream: 1

Stage	1	2
Duration	41	17
Change Point	24	73

#### Stage Stream: 2

Stage	1	2
Duration	38	23
Change Point	10	56

#### Stage Stream: 3

Stage	1	2
Duration	41	23
Change Point	33	4

#### Stage Stream: 4

Stage	1	2
Duration	57	7
Change Point	13	75

# Signal Timings Diagram

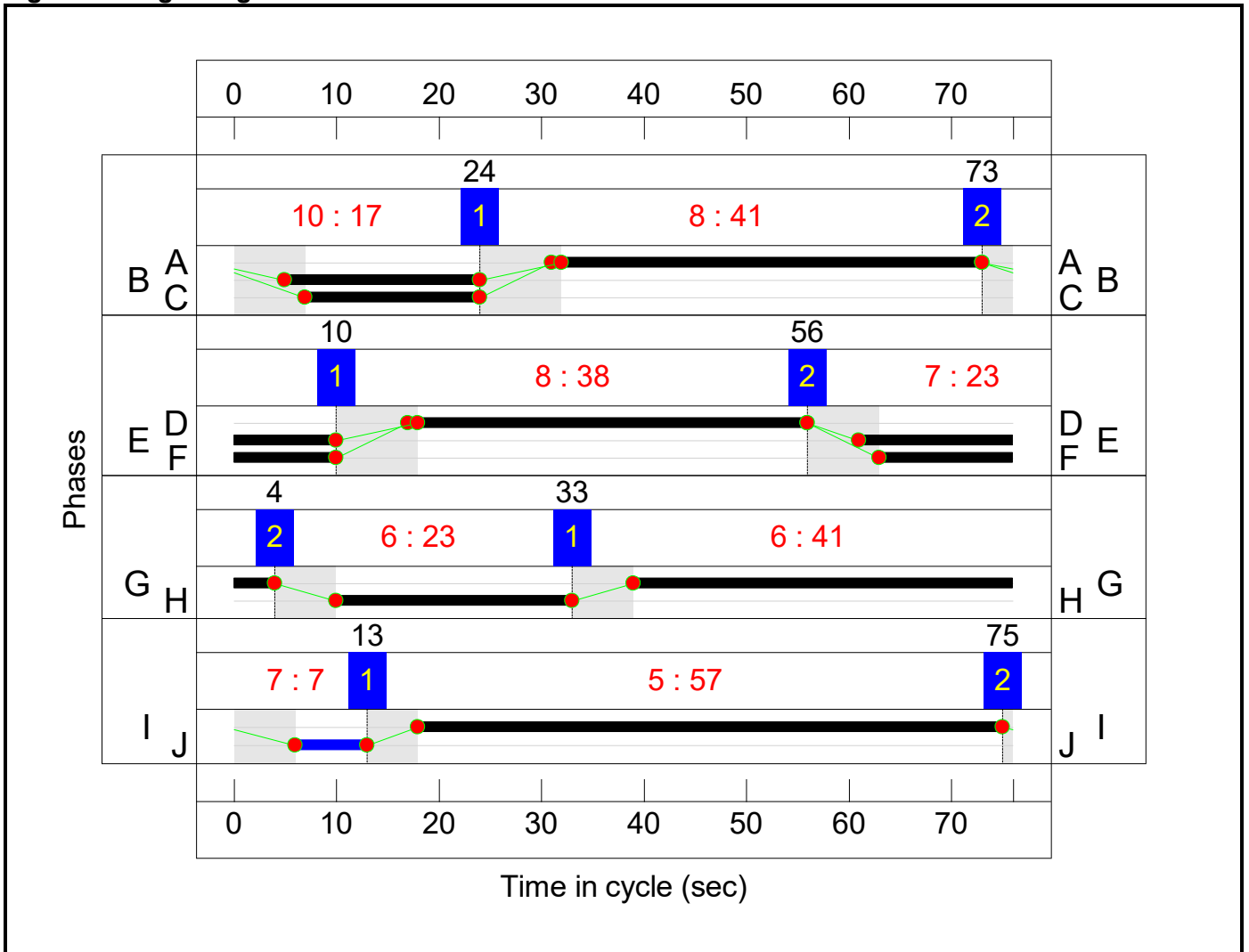

## Network Results

Item	Lane Description	Lane Type	Controller Stream	Position In Filtered Route	Full Phase	Arrow Phase	Num Greens	Total Green (s)	Arrow Green (s)	Demand Flow (pcu)	Sat Flow (pcu/Hr)	Capacity (pcu)	Deg Sat (%)
<b>Network: M1 Junction 15 impact with additional mezzanine</b>	-	-	<b>N/A</b>	-	-		-	-	-	-	-	-	<b>100.4%</b>
<b>M1 Junction 15</b>	-	-	<b>N/A</b>	-	-		-	-	-	-	-	-	<b>100.4%</b>
1/2+1/1	M1 Southbound Offslip Left	U	1:1	N/A	C1:D		1	15	-	607	2120:1980	446+417	70.4 : 70.3%
1/3+1/4	M1 Southbound Offslip Left Ahead	U	1:1	N/A	C1:D C1:C		1	15:17	-	1076	2120:4000	446+947	89.6 : 71.4%
3/1	Ahead	U	1:2	N/A	C1:I		1	25	-	137	1900	650	21.1%
3/2	Right	U	1:2	N/A	C1:I		1	25	-	222	1900	650	34.2%
3/3	Right	U	1:2	N/A	C1:H		1	24	-	274	1900	625	43.8%
3/4	Right	U	1:2	N/A	C1:H		1	24	-	353	1900	625	56.5%
4/2+4/1	A45 Southbound Left Ahead	U	1:2	N/A	C1:K		1	37	-	1073	2120:1980	1029+990	52.4 : 53.9%
4/3	A45 Southbound Ahead	U	1:2	N/A	C1:J		1	38	-	866	2120	1088	79.6%
4/4+4/5	A45 Southbound Ahead	U	1:2	N/A	C1:J		1	38	-	1749	2120:2120	851+1088	82.5 : 96.2%
6/1	M1 Northbound Circulatory Ahead	U	2:1	N/A	C2:A		1	41	-	1140	2120	1172	97.3%
6/2+6/3	M1 Northbound Circulatory Ahead Right	U	2:1	N/A	C2:A		1	41	-	1074	2120:2120	905+438	80.0 : 80.0%
6/4	M1 Northbound Circulatory Right	U	2:1	N/A	C2:A		1	41	-	1176	2120	1172	100.4%
8/1	Saxon Avenue Left Left2	U	1:3	N/A	C1:P		1	7	-	140	1884	198	70.6%
8/2	Saxon Avenue Left	U	1:3	N/A	C1:P		1	7	-	129	2105	222	58.2%
9/2+9/1	M1 Northbound Offslip Left Ahead	U	2:1	N/A	C2:B C2:C		1	19:17	-	716	2120:1980	558+239	89.8 : 89.8%

9/3+9/4	M1 Northbound Offslip Ahead	U	2:1	N/A	C2:B		1	19	-	1027	2120:2120	558+558	85.0 : 99.1%
11/1	Ahead	U	2:2	N/A	C2:D		1	38	-	652	1900	975	66.6%
11/2	Ahead Right	U	2:2	N/A	C2:D		1	38	-	874	1900	975	89.5%
12/1	Toucan Crossing Ahead	U	2:4	N/A	C2:I		1	57	-	1016	1995	1523	66.5%
12/2	Toucan Crossing Ahead	U	2:4	N/A	C2:I		1	57	-	1092	1995	1523	71.7%
13/2+13/1	A508 Northampton Rd Ahead	U	2:2	N/A	C2:F		1	23	-	729	1980:1980	552+550	66.1 : 66.1%
13/3	A508 Northampton Rd Ahead	U	2:2	N/A	C2:E		1	25	-	545	2120	725	75.1%
13/4+13/5	A508 Northampton Rd Ahead	U	2:2	N/A	C2:E		1	25	-	1231	2120:2120	725+725	81.8 : 88.0%
15/1	Ahead	U	1:1	N/A	C1:A		1	45	-	1171	2000	1211	96.7%
15/2	Ahead	U	1:1	N/A	C1:A		1	45	-	1089	2000	1211	89.9%
15/3+15/4	Ahead Right	U	1:1	N/A	C1:A C1:B		1	45	-	1191	2000:2000	1031+363	85.4 : 85.4%
16/1	Right	U	2:3	N/A	C2:H		1	23	-	501	2000	632	79.3%
16/2	Right	U	2:3	N/A	C2:H		1	23	-	474	2000	632	75.1%
16/3	Right	U	2:3	N/A	C2:H		1	23	-	553	2000	632	87.6%
17/1	Ahead	U	2:3	N/A	C2:G		1	41	-	670	2000	1105	60.6%
17/2	Ahead	U	2:3	N/A	C2:G		1	41	-	615	2000	1105	55.6%
17/3	Ahead	U	2:3	N/A	C2:G		1	41	-	638	2000	1105	57.7%
18/1	Ahead	U	1:3	N/A	C1:O		1	56	-	566	2000	1500	37.7%
18/2	Ahead	U	1:3	N/A	C1:O		1	56	-	641	2000	1500	42.7%
19/1	Ahead	U	1:3	N/A	C1:N		1	53	-	1140	2000	1421	80.2%
19/2	Ahead	U	1:3	N/A	C1:N		1	53	-	1055	2120	1506	70.0%
19/3	Ahead	U	1:3	N/A	C1:N		1	53	-	1047	2120	1506	69.5%

Item	Arriving (pcu)	Leaving (pcu)	Turners In Gaps (pcu)	Turners When Unopposed (pcu)	Turners In Intergreen (pcu)	Uniform Delay (pcuHr)	Rand + Oversat Delay (pcuHr)	Storage Area Uniform Delay (pcuHr)	Total Delay (pcuHr)	Av. Delay Per PCU (s/pcu)	Max. Back of Uniform Queue (pcu)	Rand + Oversat Queue (pcu)	Mean Max Queue (pcu)
<b>Network: M1 Junction 15 impact with additional mezzanine</b>	-	-	0	0	0	106.3	28.2	0.0	134.5	-	-	-	-
<b>M1 Junction 15</b>	-	-	0	0	0	106.3	28.2	0.0	134.5	-	-	-	-
1/2+1/1	607	607	-	-	-	4.7	1.2	-	5.9 (3.0+2.8)	34.8 (34.8:34.8)	6.1	1.2	7.3
1/3+1/4	1076	1076	-	-	-	8.2	1.7	-	9.9 (3.9+6.1)	33.2 (34.8:32.2)	8.1	1.7	9.8
3/1	137	137	-	-	-	0.3	0.0	-	0.3	8.1	0.9	0.0	0.9
3/2	222	222	-	-	-	1.5	0.0	-	1.5	24.3	4.7	0.0	4.7
3/3	274	274	-	-	-	0.5	0.0	-	0.5	6.8	1.2	0.0	1.2
3/4	353	353	-	-	-	0.4	0.0	-	0.4	4.5	0.6	0.0	0.6
4/2+4/1	1073	1073	-	-	-	3.8	0.6	-	4.4 (2.2+2.2)	14.8 (14.6:14.9)	7.7	0.6	8.3
4/3	866	866	-	-	-	3.7	1.9	-	5.6	23.2	14.9	1.9	16.8
4/4+4/5	1749	1749	-	-	-	7.8	4.4	-	12.2 (4.4+7.8)	25.1 (22.5:26.9)	21.2	4.4	25.6
6/1	1140	1140	-	-	-	6.8	0.0	-	6.8	21.4	24.1	0.0	24.1
6/2+6/3	1074	1074	-	-	-	6.6	0.0	-	6.6 (4.5+2.0)	22.0 (22.5:21.0)	22.0	0.0	22.0
6/4	1176	1172	-	-	-	4.8	2.2	-	7.0	21.5	25.0	2.2	27.2
8/1	140	140	-	-	-	1.3	1.2	-	2.4	62.6	2.8	1.2	4.0
8/2	129	129	-	-	-	1.2	0.7	-	1.8	51.6	2.6	0.7	3.3
9/2+9/1	716	716	-	-	-	5.2	4.0	-	9.3 (6.6+2.7)	46.5 (47.2:45.0)	10.2	4.0	14.2
9/3+9/4	1027	1027	-	-	-	7.8	5.2	-	13.0 (5.9+7.1)	45.5 (44.7:46.1)	11.5	5.2	16.7
11/1	649	649	-	-	-	4.2	0.0	-	4.2	23.3	9.3	0.0	9.3
11/2	873	873	-	-	-	4.5	0.0	-	4.5	18.6	9.6	0.0	9.6
12/1	1013	1013	-	-	-	0.4	0.0	-	0.4	1.3	2.2	0.0	2.2

12/2	1092	1092	-	-	-	0.3	0.0	-	0.3	1.1	2.1	0.0	2.1
13/2+13/1	729	729	-	-	-	4.4	1.0	-	5.4 (2.7+2.7)	26.6 (26.6:26.6)	6.4	1.0	7.4
13/3	545	545	-	-	-	3.4	1.5	-	4.8	32.0	10.1	1.5	11.6
13/4+13/5	1231	1231	-	-	-	7.9	2.7	-	10.7 (5.1+5.6)	31.2 (30.8:31.5)	12.6	2.7	15.3
15/1	1171	1171	-	-	-	3.4	0.0	-	3.4	10.5	24.6	0.0	24.6
15/2	1088	1088	-	-	-	2.7	0.0	-	2.7	9.0	18.3	0.0	18.3
15/3+15/4	1191	1191	-	-	-	1.4	0.0	-	1.4 (0.9+0.5)	4.2 (3.7:5.7)	16.5	0.0	16.5
16/1	501	501	-	-	-	0.1	0.0	-	0.1	0.5	0.6	0.0	0.6
16/2	474	474	-	-	-	0.1	0.0	-	0.1	0.5	0.5	0.0	0.5
16/3	553	553	-	-	-	0.1	0.0	-	0.1	0.6	0.6	0.0	0.6
17/1	670	670	-	-	-	1.7	0.0	-	1.7	9.2	4.8	0.0	4.8
17/2	614	614	-	-	-	2.0	0.0	-	2.0	11.6	4.6	0.0	4.6
17/3	638	638	-	-	-	2.4	0.0	-	2.4	13.6	5.1	0.0	5.1
18/1	566	566	-	-	-	0.3	0.0	-	0.3	1.9	3.4	0.0	3.4
18/2	641	641	-	-	-	0.4	0.0	-	0.4	2.0	3.2	0.0	3.2
19/1	1140	1140	-	-	-	0.8	0.0	-	0.8	2.4	3.1	0.0	3.1
19/2	1055	1055	-	-	-	0.4	0.0	-	0.4	1.4	2.0	0.0	2.0
19/3	1047	1047	-	-	-	0.9	0.0	-	0.9	3.2	3.3	0.0	3.3

C1 - Eastside Controller	Stream: 1 PRC for Signalled Lanes (%)	-7.5	Total Delay for Signalled Lanes (pcuHr)	23.33	Cycle Time (s)	76
C1 - Eastside Controller	Stream: 2 PRC for Signalled Lanes (%)	-6.9	Total Delay for Signalled Lanes (pcuHr)	24.95	Cycle Time (s)	76
C1 - Eastside Controller	Stream: 3 PRC for Signalled Lanes (%)	12.2	Total Delay for Signalled Lanes (pcuHr)	7.06	Cycle Time (s)	76
C2 - Westside Controller	Stream: 1 PRC for Signalled Lanes (%)	-11.5	Total Delay for Signalled Lanes (pcuHr)	42.56	Cycle Time (s)	76
C2 - Westside Controller	Stream: 2 PRC for Signalled Lanes (%)	0.6	Total Delay for Signalled Lanes (pcuHr)	29.61	Cycle Time (s)	76
C2 - Westside Controller	Stream: 3 PRC for Signalled Lanes (%)	2.8	Total Delay for Signalled Lanes (pcuHr)	6.32	Cycle Time (s)	76
C2 - Westside Controller	Stream: 4 PRC for Signalled Lanes (%)	25.5	Total Delay for Signalled Lanes (pcuHr)	0.69	Cycle Time (s)	76
	PRC Over All Lanes (%)	-11.5	Total Delay Over All Lanes(pcuHr)	134.52		

APPENDIX 2  
SUPPORTING LETTER

2 December 2024

FAO Martin Seldon  
 National Highways  
 The Cube  
 199 Wharfside Street  
 Birmingham  
 B1 1RN

Dear Martin,

**NORTHAMPTON GATEWAY SRFI DCO AMENDMENT TO INCREASE MEZZANINE FLOOR SPACE**

Thank you for providing comments on our updated TA Addendum and accompanying LinSig files. Your comments are included in your email of 19 November 2024.

The purpose of this letter is to address the comments and provide the additional information requested. We have responded to each of the points in the order set out in your email.

<b>M1 Junction 15</b>		
<b>Ref</b>	<b>NH comment</b>	<b>ADC response</b>
1.	Model Structure: Please can you clarify whether Arm 3, Lane 1 should be connected to Arm 18, Lane 1, rather than from Arm 3, Lane 2? The nearside lane of this arm (Arm 3) is marked for both M1(S) and Grange Park, but the LinSig model allows only traffic into Saxon Avenue	The observation is correct and the model has been amended accordingly. The overall junction performance is unaffected with no material change in capacity or delay due to the additional traffic. The revised model output is enclosed with this letter and the digital LinSig file will be provided via email.
2.	Traffic Flows: It is our understanding that, Flow Group 7 (2031 J1d Dev AM Peak) and Flow Group 8 (2031 J1d Dev PM Peak) of the old model (180221 M1 Junction 15 Mitigation with WL.lsg3x), have been copied across to the new model as Flow Group 1 (2031 background – AM) and Flow Group 2 (2031 background – PM). Please can you confirm that this is the case?	This is correct.
	If the above flow assumption is correct, please can you explain why the new model sees the introduction of M1 North to M1 North U-turning flows in the AM and PM peaks? We note that this movement was not included in the previous revision of the model.	The original NSTM data included a small number of U-turns for the M1 North (3 in the AM peak and 0 in PM peak). These were ignored in the original TA modelling but were reintroduced into the revised modelling for completeness.
3.	Signal Controllers:	

	<p>a. Controller 1 – North Side: Phase G has been coded into the LinSig model with a minimum green time of 5 seconds, however the controller specification document has a minimum green of 7 seconds. While this is not expected to change the model results, please can this be updated.</p> <p>b. Controller 2 – South Side: The controller specification document shows a phase delay value for Phase F, but this does not appear to have been coded into the LinSig model. Is there a reason for this?</p>	<p>The minimum green for phase G has been changed to 7 seconds as requested, with no material change to the model results.</p> <p>The phase delay has been included in the revised model. The purpose of this 8 second phase delay is unclear as it does not positively improve performance. However, it's effects are equal in the 'background' and 'with additional mez' scenarios and the overall junction performance is unaffected with no material change in capacity or delay due to the additional traffic. Hence, the junction could accommodate the additional traffic associated with the increased mezzanine floor space with no material impact on performance.</p>
--	--	--

<b>A508/Site Access Gyratory</b>		
<b>Ref</b>	<b>NH comment</b>	<b>ADC response</b>
	Please can you provide us with a scaled drawing (preferably in CAD format) so that the geometric parameters entered in the model can be verified.	Please find enclosed <b>drawing 3519-ADC-ZZ-XX-DR-Z-0100</b> , which will also be provided by dwg via email.
1.	<p>Traffic Flows: There seems to be an inconsistency in traffic flows on the A508 between this junction and the M1 Junction. The flow leaving or entering this roundabout on Arm A does not arrive or leave the M1 model on Arm D. These differences have been highlighted in Diagrams 7 and 8, but it is not clear why these discrepancies occur.</p> <p>In the PM Peak, the model has assigned zero flow to the nearside lane of the southern circulatory (Arm 8, Lane 1). Please can you confirm this is realistic? Would no traffic use the nearside lane either by merging across or being fed from the upstream middle lane? If flows are not correctly assigned to the</p>	<p>The agreed approach in the TA for the DCO was that all off-site junctions were assessed using the 'Actual' traffic flows from the NSTM. Hence M1 J15 is assessed using the 'Actual' traffic flow set. However, the site access was assessed using the 'Demand' traffic flows, to ensure that all development traffic was accounted for. Hence, this is the reason for the difference between the two junctions. However, this is consistent with the agreed approach taken in the TA.</p> <p>Agreed. The PM assignment has been manually adjusted to feed some right-turning traffic from the upstream middle lane to the nearside lane of the southern circulatory (Arm 8, Lane 1). The revised model output is enclosed with this letter and the digital LinSig file will be provided via email.</p>

	<p>circulatory lanes, it could possibly affect the predicted level of queuing on adjacent approach to the roundabout. With the flow levels on the A508 Southbound approach and the length of the offside flare, it may not be appropriate to rely on the LinSig Delay Based Assignment. A certain degree of manual adjustments may be more realistic, depending on how the southbound approach offside flare is used once the initial queue clears following the start of the green period.</p>	<p>The revised model, including the amendments discussed above and below, shows that the junction would have a positive Practical reserve capacity of 6.1% in the morning peak hour and 8.6% in the evening peak hour and there would be no material delay or queueing. Hence, the mitigated junction could acceptably accommodate the additional traffic associated with the increased mezzanine floor space.</p>
2.	<p>Model Structure: The northern circulatory (Arm 7), adjacent to the A508 Southbound approach, only shows a single lane. However, but Figure 7 in the “DCO Amendment” report shows it as two lanes. Is there a reason for modelling the arm in that way?</p>	<p>The right-turn flow from the site is relatively low and hence was modelled in a single lane for simplicity. However, the model has been amended to show two lanes.</p>
	<p>The site access arm (Arm 6) does not show the two lanes that enter the roundabout, but just a single lane (Arm 6, lane 2). Please can you explain why it has been modelled as a single lane?</p>	<p>As above.</p>
	<p>The LinSig model does not include the pedestrian crossings located on the A508 Northbound exit and the left turn on the site access arm. Please can you justify the exclusion of these two crossings from the model?</p>	<p>These crossings would be called infrequently and would not impact on the overall performance of the junction.</p>
3.	<p>Intergreen measurements: Although a scaled drawing has not been supplied, it appears that the intergreen value of 8 seconds on the A508 Southbound entry pedestrian crossing (Phase C) may be too low, as pedestrians have to walk across three lanes of traffic. Please can you confirm this value is correct? For our reference, are you able to supply us with the existing controller specification documents for the signalised crossings currently located at the roundabout</p>	<p>A reduced intergreen is used to account for the effect of on-crossing detection on the extendable period of the intergreen. Further, in this instance the crossing would be called infrequently during a peak hour and therefore the reduced intergreen reflects the aggregate effect across the hour.</p>
	<p>Give Way Data: Please can you set out how the give way parameters on the A508 South (Arm 4) and Site Access (Arm 6) approaches have been determined? The A508 South approach seems to have calculated values, whilst the site access arm uses the standard values suggested by JCT. We would recommend you calculate the values for each lane and then show us in a</p>	<p>The slope and intercept values for the A508 South approach have been taken from the Arcady assessment submitted with the Transport Assessment (Appendix 48) in support of the DCO application. The capacity of this approach in the LinSig model correlates very closely to the results shown in the Arcady model.</p>

	supporting CAD file, the geometric parameters used to calculate the Slope and Intercept values that are used in the LinSig model, as the Coefficient and Maximum Flow values respectively.	
--	--	--

We trust that the above and enclosed are satisfactory for your purposes. However, should you have any further questions, please do not hesitate to contact me.

Yours sincerely,

**Mark Higgins**

Associate Director

Mob: 07532 112800

[Mark.Higgins@ADCinfrastructure.com](mailto:Mark.Higgins@ADCinfrastructure.com)

Enc      Drawing 3519-ADC-ZZ-XX-DR-Z-0100  
            241129 M1 Junction 15 – impact due to additional mez (LinSig output)  
            241129 site access gyratory – proposed mitigation (LinSig output)

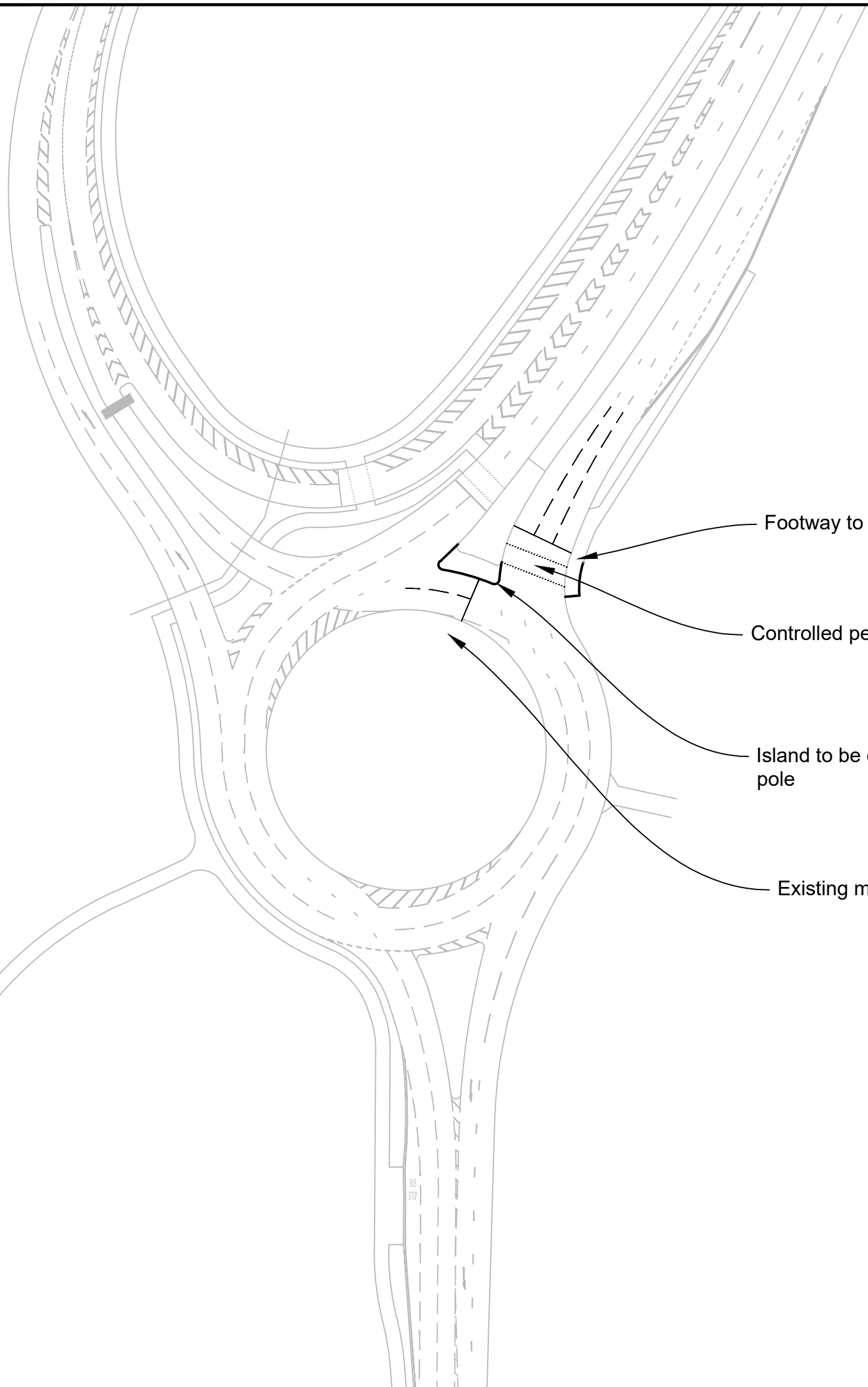
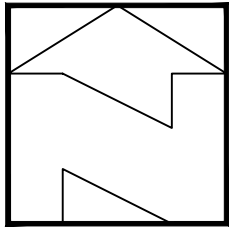

Footway to be extended

Controlled pedestrian crossing relocated

Island to be extended to accommodate traffic signal pole

Existing maintenance bay would need to be relocated

General Notes

1. Do not scale this drawing. All dimensions must be checked/verified on site.
2. This drawing is to be read in conjunction with all relevant architects, engineers and specialists drawings and specifications.
3. All dimensions are in metres unless noted otherwise. All levels are in metres unless noted otherwise.
4. Any discrepancies noted on site are to be reported to the engineer immediately.

P01	29.11.24	First issue	MH	SD
-----	----------	-------------	----	----

Rev	Date	Description	Dr	Ch
-----	------	-------------	----	----

Client:  
**Segro**

Project:  
**Northampton Gateway - DCO amendment to increase mezzanine floor space**

Title:  
**Proposed site access roundabout mitigation**



© ADC Infrastructure Limited

Size:	A3	Scale:	1:1000
-------	----	--------	--------

Status:  
**PRELIMINARY**

Project	Originator	Volume	Level	Type	Role	Number	Status	Revision
3519	-ADC-	ZZ	-XX-	DR-	Z	-0100	S1	P01

## Full Input Data And Results

### User and Project Details

<b>Project:</b>	<b>Northampton Gateway</b>
<b>Title:</b>	<b>M1 Junction 15 impact with additional mezzanine</b>
<b>Location:</b>	northampton
<b>Client:</b>	Segro
<b>Additional detail:</b>	PM peak hour flows amended following feedback from NH. NB: adjustment made following removal of the Watering Lane Junction.  241129 amended model following comments from NH.
<b>File name:</b>	241129 M1 Junction 15 Mitigation - additional mez test.lsg3x
<b>Author:</b>	Mark Higgins
<b>Company:</b>	ADC Infrastructure
<b>Address:</b>	Nottingham

# Network Layout Diagram

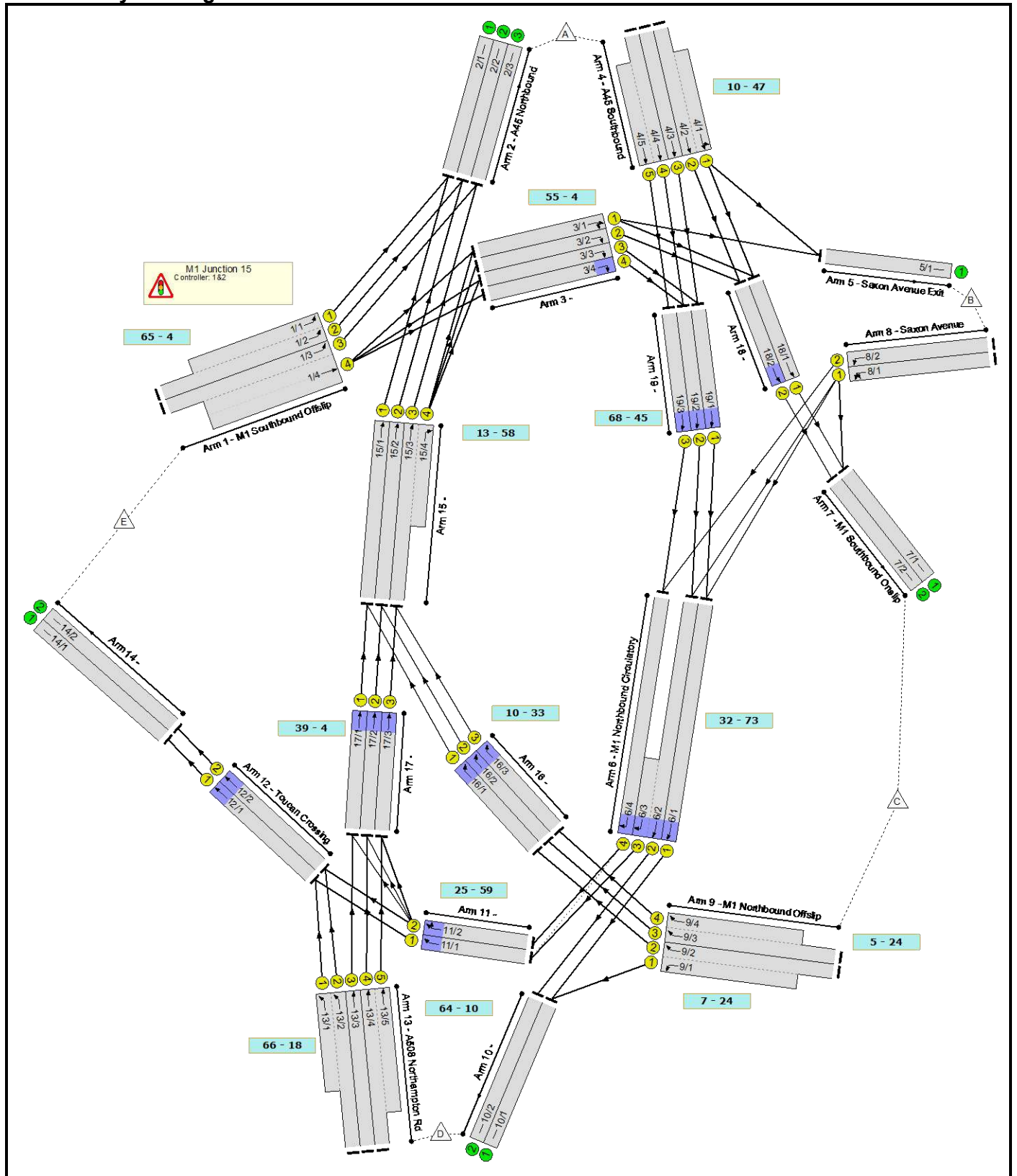

**C1 - Eastside Controller  
Phase Diagram**

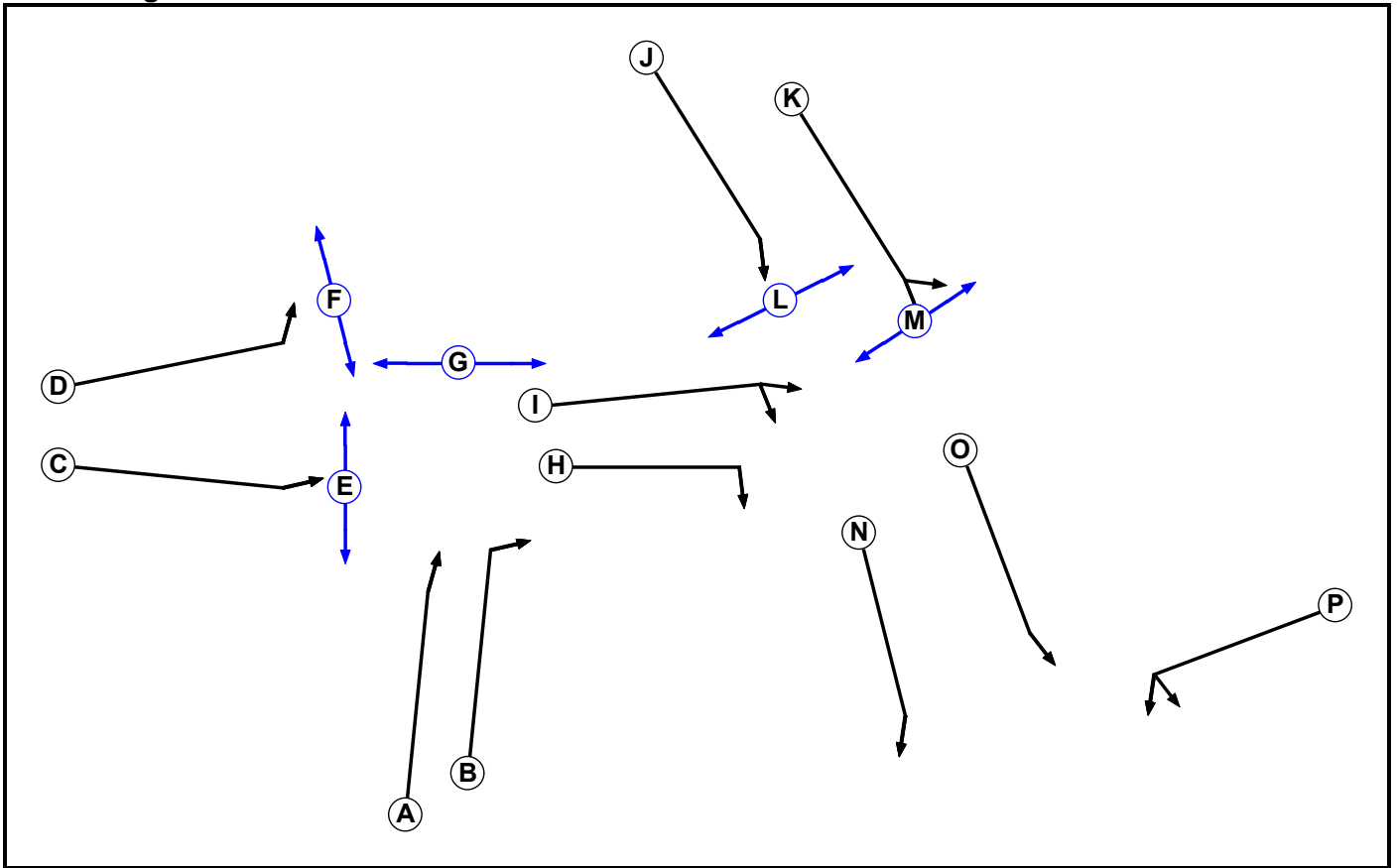

**Phase Input Data**

Phase Name	Phase Type	Stage Stream	Assoc. Phase	Street Min	Cont Min
A	Traffic	1		7	7
B	Traffic	1		7	7
C	Traffic	1		7	7
D	Traffic	1		7	7
E	Pedestrian	1		5	5
F	Pedestrian	1		5	5
G	Pedestrian	1		7	7
H	Traffic	2		7	7
I	Traffic	2		7	7
J	Traffic	2		7	7
K	Traffic	2		7	7
L	Pedestrian	2		5	5
M	Pedestrian	2		5	5
N	Traffic	3		7	7
O	Traffic	3		7	7
P	Traffic	3		7	7

### Phase Intergrens Matrix

		Starting Phase															
		A	B	C	D	E	F	G	H	I	J	K	L	M	N	O	P
Terminating Phase	A	-	-	5	7	-	-	8	-	-	-	-	-	-	-	-	-
	B	-	-	5	-	-	-	-	-	-	-	-	-	-	-	-	-
	C	9	9	-	-	7	-	-	-	-	-	-	-	-	-	-	-
	D	9	-	-	-	-	7	-	-	-	-	-	-	-	-	-	-
	E	-	-	5	-	-	-	-	-	-	-	-	-	-	-	-	-
	F	-	-	-	5	-	-	-	-	-	-	-	-	-	-	-	-
	G	5	-	-	-	-	-	-	-	-	-	-	-	-	-	-	-
	H	-	-	-	-	-	-	-	-	-	5	6	-	-	-	-	-
	I	-	-	-	-	-	-	-	-	-	5	6	-	-	-	-	-
	J	-	-	-	-	-	-	-	9	8	-	-	7	-	-	-	-
	K	-	-	-	-	-	-	-	-	7	-	-	-	7	-	-	-
	L	-	-	-	-	-	-	-	-	-	5	-	-	-	-	-	-
	M	-	-	-	-	-	-	-	-	-	-	5	-	-	-	-	-
	N	-	-	-	-	-	-	-	-	-	-	-	-	-	-	-	5
O	-	-	-	-	-	-	-	-	-	-	-	-	-	-	-	6	
P	-	-	-	-	-	-	-	-	-	-	-	-	-	10	7	-	

### Phases in Stage

Stream	Stage No.	Phases in Stage
1	1	A B E F
1	2	C D G
2	1	H I L M
2	2	J K
3	1	N O
3	2	P

### Stage Diagram

#### Stage Stream: 1

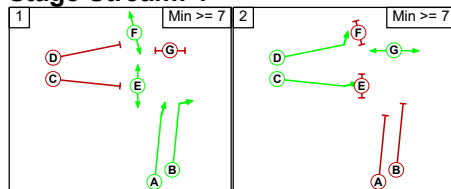

#### Stage Stream: 2

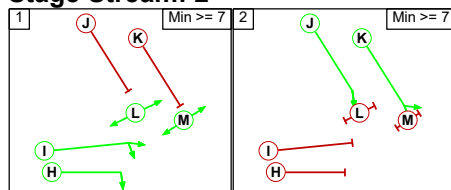

### Stage Stream: 3

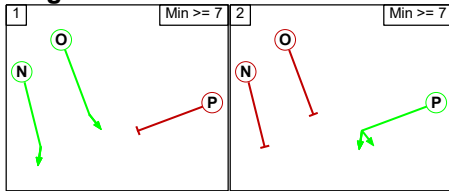

### Phase Delays

#### Stage Stream: 1

Term. Stage	Start Stage	Phase	Type	Value	Cont value
There are no Phase Delays defined					

#### Stage Stream: 2

Term. Stage	Start Stage	Phase	Type	Value	Cont value
There are no Phase Delays defined					

#### Stage Stream: 3

Term. Stage	Start Stage	Phase	Type	Value	Cont value
There are no Phase Delays defined					

### Prohibited Stage Change

#### Stage Stream: 1

From Stage	To Stage	
	1	2
1	8	
2	9	

#### Stage Stream: 2

From Stage	To Stage	
	1	2
1	6	
2	9	

#### Stage Stream: 3

From Stage	To Stage	
	1	2
1	6	
2	10	

**C2 - Westside Controller  
Phase Diagram**

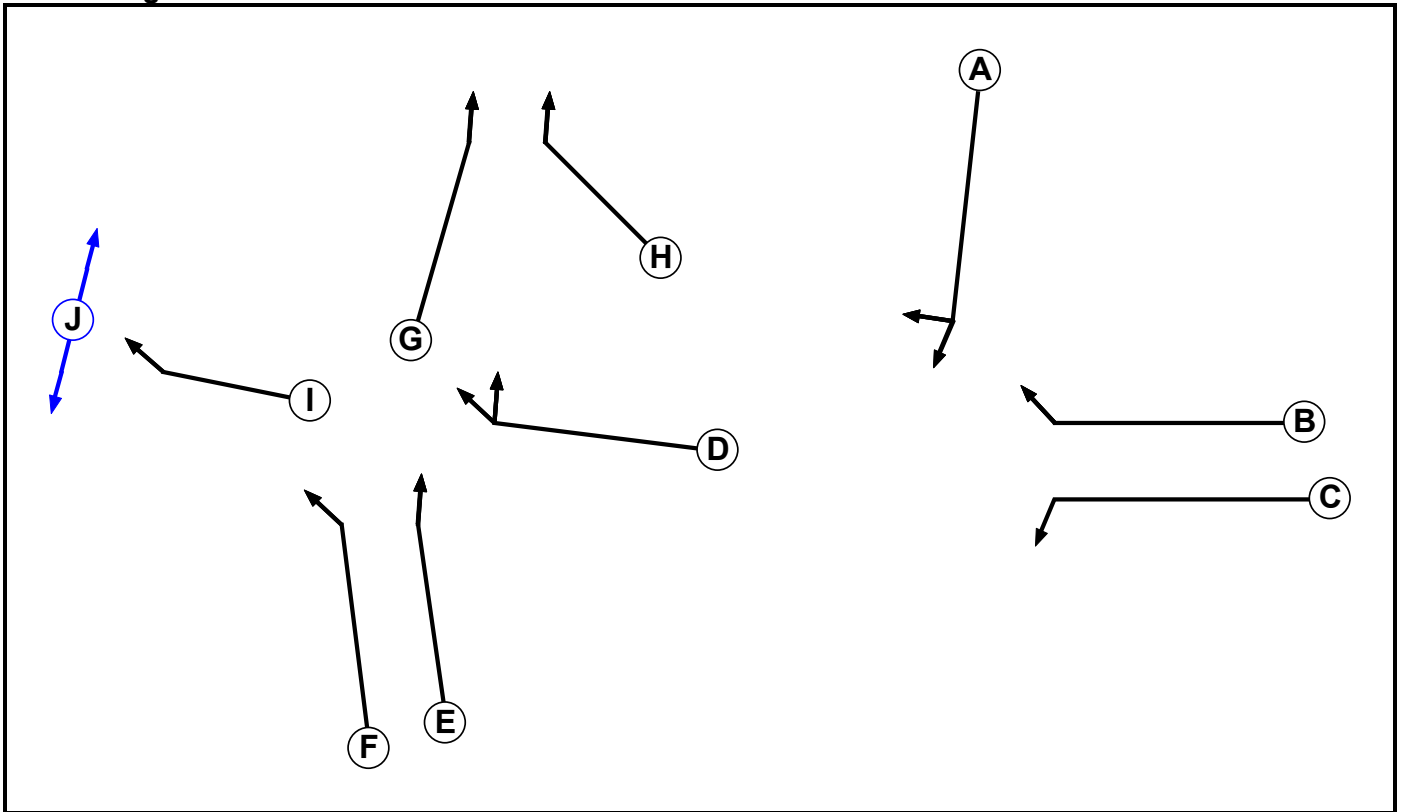

**Phase Input Data**

Phase Name	Phase Type	Stage Stream	Assoc. Phase	Street Min	Cont Min
A	Traffic	1		7	7
B	Traffic	1		7	7
C	Traffic	1		7	7
D	Traffic	2		7	7
E	Traffic	2		7	7
F	Traffic	2		7	0
G	Traffic	3		7	7
H	Traffic	3		7	7
I	Traffic	4		7	7
J	Pedestrian	4		5	5

### Phase Intergrens Matrix

		Starting Phase									
		A	B	C	D	E	F	G	H	I	J
Terminating Phase	A		8	10	-	-	-	-	-	-	-
	B	8		-	-	-	-	-	-	-	-
	C	7	-		-	-	-	-	-	-	-
	D	-	-	-		5	7	-	-	-	-
	E	-	-	-	8		-	-	-	-	-
	F	-	-	-	7	-		-	-	-	-
	G	-	-	-	-	-	-		6	-	-
	H	-	-	-	-	-	-	6		-	-
	I	-	-	-	-	-	-	-	-		7
	J	-	-	-	-	-	-	-	-	5	

### Phases in Stage

Stream	Stage No.	Phases in Stage
1	1	A
1	2	B C
2	1	D
2	2	E F
3	1	G
3	2	H
4	1	I
4	2	J

### Stage Diagram

#### Stage Stream: 1

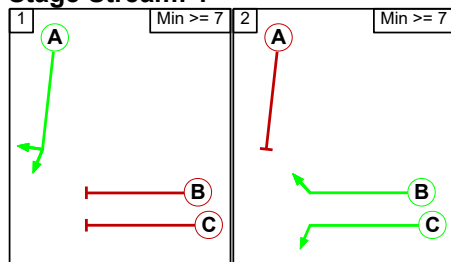

#### Stage Stream: 2

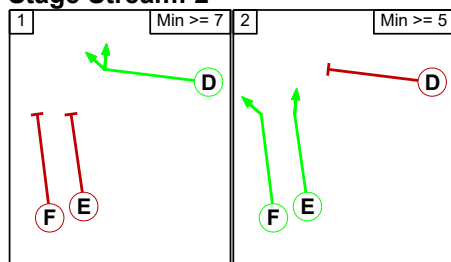

### Stage Stream: 3

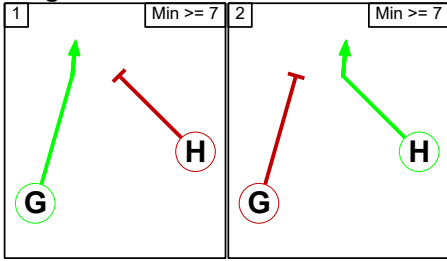

### Stage Stream: 4

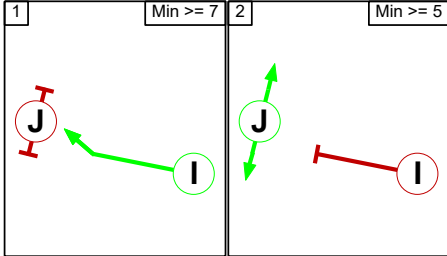

### Phase Delays

#### Stage Stream: 1

Term. Stage	Start Stage	Phase	Type	Value	Cont value
There are no Phase Delays defined					

#### Stage Stream: 2

Term. Stage	Start Stage	Phase	Type	Value	Cont value
2	1	F	Losing	8	8

#### Stage Stream: 3

Term. Stage	Start Stage	Phase	Type	Value	Cont value
There are no Phase Delays defined					

#### Stage Stream: 4

Term. Stage	Start Stage	Phase	Type	Value	Cont value
There are no Phase Delays defined					

### Prohibited Stage Change

#### Stage Stream: 1

		To Stage	
From Stage	1	1	2
	2	10	
	8		

#### Stage Stream: 2

		To Stage	
From Stage	1	1	7
	2	15	

**Stage Stream: 3**

	To Stage	
From Stage		1 2
	1	6
	2	6

**Stage Stream: 4**

	To Stage	
From Stage		1 2
	1	7
	2	5

## Lane Input Data

Junction: M1 Junction 15												
Lane	Lane Type	Phases	Start Disp.	End Disp.	Physical Length (PCU)	Sat Flow Type	Def User Saturation Flow (PCU/Hr)	Lane Width (m)	Gradient	Nearside Lane	Turns	Turning Radius (m)
1/1 (M1 Southbound Offslip)	U	D	2	3	18.0	Geom	-	3.65	0.00	Y	Arm 2 Left	Inf
1/2 (M1 Southbound Offslip)	U	D	2	3	60.0	Geom	-	3.65	0.00	N	Arm 2 Left	Inf
1/3 (M1 Southbound Offslip)	U	D	2	3	60.0	Geom	-	3.65	0.00	N	Arm 2 Left	Inf
1/4 (M1 Southbound Offslip)	U	C	2	3	18.0	User	4000	-	-	-	-	-
2/1 (A45 Northbound)	U		2	3	4.3	Inf	-	-	-	-	-	-
2/2 (A45 Northbound)	U		2	3	4.3	Inf	-	-	-	-	-	-
2/3 (A45 Northbound)	U		2	3	4.3	Inf	-	-	-	-	-	-
3/1	U	I	2	3	11.3	User	1900	-	-	-	-	-
3/2	U	I	2	3	11.3	User	1900	-	-	-	-	-
3/3	U	H	2	3	11.3	User	1900	-	-	-	-	-
3/4	U	H	2	3	11.3	User	1900	-	-	-	-	-
4/1 (A45 Southbound)	U	K	2	3	33.0	Geom	-	3.65	0.00	Y	Arm 5 Left	Inf
											Arm 18 Ahead	Inf
4/2 (A45 Southbound)	U	K	2	3	67.8	Geom	-	3.65	0.00	N	Arm 18 Ahead	Inf
4/3 (A45 Southbound)	U	J	2	3	67.8	Geom	-	3.65	0.00	N	Arm 19 Ahead	Inf
4/4 (A45 Southbound)	U	J	2	3	67.8	Geom	-	3.65	0.00	N	Arm 19 Ahead	Inf
4/5 (A45 Southbound)	U	J	2	3	33.0	Geom	-	3.65	0.00	N	Arm 19 Ahead	Inf
5/1 (Saxon Avenue Exit)	U		2	3	4.3	Inf	-	-	-	-	-	-

6/1 (M1 Northbound Circulatory)	U	A	2	3	33.9	User	2120	-	-	-	-	-
6/2 (M1 Northbound Circulatory)	U	A	2	3	33.9	User	2120	-	-	-	-	-
6/3 (M1 Northbound Circulatory)	U	A	2	3	8.0	User	2120	-	-	-	-	-
6/4 (M1 Northbound Circulatory)	U	A	2	3	33.9	User	2120	-	-	-	-	-
7/1 (M1 Southbound Onslip)	U		2	3	4.3	Inf	-	-	-	-	-	-
7/2 (M1 Southbound Onslip)	U		2	3	4.3	Inf	-	-	-	-	-	-
8/1 (Saxon Avenue)	U	P	2	3	60.0	Geom	-	3.50	0.00	Y	Arm 6 Left	Inf
											Arm 7 Left	30.00
8/2 (Saxon Avenue)	U	P	2	3	60.0	Geom	-	3.50	0.00	N	Arm 6 Left	Inf
9/1 (M1 Northbound Offslip)	U	C	2	3	15.7	Geom	-	3.65	0.00	Y	Arm 10 Left	Inf
9/2 (M1 Northbound Offslip)	U	B	2	3	60.0	Geom	-	3.65	0.00	N	Arm 16 Ahead	Inf
9/3 (M1 Northbound Offslip)	U	B	2	3	60.0	Geom	-	3.65	0.00	N	Arm 16 Ahead	Inf
9/4 (M1 Northbound Offslip)	U	B	2	3	31.3	Geom	-	3.65	0.00	N	Arm 16 Ahead	Inf
10/1	U		2	3	4.3	Inf	-	-	-	-	-	-
10/2	U		2	3	4.3	Inf	-	-	-	-	-	-
11/1	U	D	2	3	20.0	User	1900	-	-	-	-	-
11/2	U	D	2	3	20.0	User	1900	-	-	-	-	-
12/1 (Toucan Crossing)	U	I	2	3	7.0	Geom	-	3.80	0.00	Y	Arm 14 Ahead	Inf
12/2 (Toucan Crossing)	U	I	2	3	7.0	Geom	-	3.80	0.00	Y	Arm 14 Ahead	Inf

13/1 (A508 Northampton Rd)	U	F	2	3	10.0	Geom	-	3.65	0.00	Y	Arm 12 Ahead	Inf
13/2 (A508 Northampton Rd)	U	F	2	3	60.0	Geom	-	3.65	0.00	Y	Arm 12 Ahead	Inf
13/3 (A508 Northampton Rd)	U	E	2	3	60.0	Geom	-	3.65	0.00	N	Arm 17 Ahead	Inf
13/4 (A508 Northampton Rd)	U	E	2	3	60.0	Geom	-	3.65	0.00	N	Arm 17 Ahead	Inf
13/5 (A508 Northampton Rd)	U	E	2	3	20.0	Geom	-	3.65	0.00	N	Arm 17 Ahead	Inf
14/1	U		2	3	60.0	Inf	-	-	-	-	-	-
14/2	U		2	3	60.0	Inf	-	-	-	-	-	-
15/1	U	A	2	3	34.8	User	2000	-	-	-	-	-
15/2	U	A	2	3	34.8	User	2000	-	-	-	-	-
15/3	U	A	2	3	34.8	User	2000	-	-	-	-	-
15/4	U	B	2	3	10.4	User	2000	-	-	-	-	-
16/1	U	H	2	3	10.4	User	2000	-	-	-	-	-
16/2	U	H	2	3	10.4	User	2000	-	-	-	-	-
16/3	U	H	2	3	10.4	User	2000	-	-	-	-	-
17/1	U	G	2	3	14.8	User	2000	-	-	-	-	-
17/2	U	G	2	3	14.8	User	2000	-	-	-	-	-
17/3	U	G	2	3	14.8	User	2000	-	-	-	-	-
18/1	U	O	2	3	11.3	User	2000	-	-	-	-	-
18/2	U	O	2	3	11.3	User	2000	-	-	-	-	-
19/1	U	N	2	3	13.0	User	2000	-	-	-	-	-
19/2	U	N	2	3	13.0	User	2120	-	-	-	-	-
19/3	U	N	2	3	13.0	User	2120	-	-	-	-	-

### Traffic Flow Groups

Flow Group	Start Time	End Time	Duration	Formula
1: '2031 background - AM'	08:00	09:00	01:00	
2: '2031 background - PM'	17:00	18:00	01:00	
3: '2031 with additional mez - AM'	08:00	09:00	01:00	
4: '2031 with additional mez - PM'	17:00	18:00	01:00	

**Scenario 1: '2031 Background - AM'** (FG1: '2031 background - AM', Plan 1: 'Network Control Plan 1')  
**Traffic Flows, Desired**  
**Desired Flow :**

		Destination					
		A	B	C	D	E	Tot.
Origin	A	35	32	959	1105	1714	3845
	B	41	0	20	17	67	145
	C	1705	51	0	330	0	2086
	D	715	25	198	31	649	1618
	E	1230	116	0	784	3	2133
	Tot.	3726	224	1177	2267	2433	9827

## Traffic Lane Flows

Lane	Scenario 1: 2031 Background - AM
<b>Junction: M1 Junction 15</b>	
1/1 (short)	376
1/2 (with short)	779(In) 403(Out)
1/3 (with short)	1354(In) 451(Out)
1/4 (short)	903
2/1	1299
2/2	1318
2/3	1109
3/1	291
3/2	99
3/3	319
3/4	499
4/1 (short)	493
4/2 (with short)	991(In) 498(Out)
4/3	944
4/4 (with short)	1910(In) 956(Out)
4/5 (short)	954
5/1	224
6/1	1263
6/2 (with short)	1503(In) 674(Out)
6/3 (short)	829
6/4	1031
7/1	580
7/2	597
8/1	68
8/2	77
9/1 (short)	330
9/2 (with short)	914(In) 584(Out)
9/3 (with short)	1172(In) 586(Out)
9/4 (short)	586
10/1	1593
10/2	674
11/1	900

11/2	960
12/1	1224
12/2	1209
13/1 (short)	324
13/2 (with short)	649(In) 325(Out)
13/3	304
13/4 (with short)	665(In) 329(Out)
13/5 (short)	336
14/1	1224
14/2	1209
15/1	923
15/2	915
15/3 (with short)	963(In) 658(Out)
15/4 (short)	305
16/1	584
16/2	586
16/3	586
17/1	339
17/2	329
17/3	377
18/1	560
18/2	597
19/1	1263
19/2	1455
19/3	954

## Lane Saturation Flows

Junction: M1 Junction 15								
Lane	Lane Width (m)	Gradient	Nearside Lane	Allowed Turns	Turning Radius (m)	Turning Prop.	Sat Flow (PCU/Hr)	Flared Sat Flow (PCU/Hr)
1/1 (M1 Southbound Offslip)	3.65	0.00	Y	Arm 2 Left	Inf	100.0 %	1980	1980
1/2 (M1 Southbound Offslip)	3.65	0.00	N	Arm 2 Left	Inf	100.0 %	2120	2120
1/3 (M1 Southbound Offslip)	3.65	0.00	N	Arm 2 Left	Inf	100.0 %	2120	2120
1/4 (M1 Southbound Offslip Lane 4)	This lane uses a directly entered Saturation Flow						4000	4000
2/1 (A45 Northbound Lane 1)	Infinite Saturation Flow						Inf	Inf
2/2 (A45 Northbound Lane 2)	Infinite Saturation Flow						Inf	Inf
2/3 (A45 Northbound Lane 3)	Infinite Saturation Flow						Inf	Inf
3/1	This lane uses a directly entered Saturation Flow						1900	1900
3/2	This lane uses a directly entered Saturation Flow						1900	1900
3/3	This lane uses a directly entered Saturation Flow						1900	1900
3/4	This lane uses a directly entered Saturation Flow						1900	1900
4/1 (A45 Southbound)	3.65	0.00	Y	Arm 5 Left	Inf	6.5 %	1980	1980
				Arm 18 Ahead	Inf	93.5 %		
4/2 (A45 Southbound)	3.65	0.00	N	Arm 18 Ahead	Inf	100.0 %	2120	2120
4/3 (A45 Southbound)	3.65	0.00	N	Arm 19 Ahead	Inf	100.0 %	2120	2120
4/4 (A45 Southbound)	3.65	0.00	N	Arm 19 Ahead	Inf	100.0 %	2120	2120
4/5 (A45 Southbound)	3.65	0.00	N	Arm 19 Ahead	Inf	100.0 %	2120	2120
5/1 (Saxon Avenue Exit Lane 1)	Infinite Saturation Flow						Inf	Inf
6/1 (M1 Northbound Circulatory Lane 1)	This lane uses a directly entered Saturation Flow						2120	2120
6/2 (M1 Northbound Circulatory Lane 2)	This lane uses a directly entered Saturation Flow						2120	2120
6/3 (M1 Northbound Circulatory Lane 3)	This lane uses a directly entered Saturation Flow						2120	2120
6/4 (M1 Northbound Circulatory Lane 4)	This lane uses a directly entered Saturation Flow						2120	2120
7/1 (M1 Southbound Onslip Lane 1)	Infinite Saturation Flow						Inf	Inf
7/2 (M1 Southbound Onslip Lane 2)	Infinite Saturation Flow						Inf	Inf

8/1 (Saxon Avenue)	3.50	0.00	Y	Arm 6 Left	Inf	70.6 %	1937	1937
				Arm 7 Left	30.00	29.4 %		
8/2 (Saxon Avenue)	3.50	0.00	N	Arm 6 Left	Inf	100.0 %	2105	2105
9/1 (M1 Northbound Offslip)	3.65	0.00	Y	Arm 10 Left	Inf	100.0 %	1980	1980
9/2 (M1 Northbound Offslip)	3.65	0.00	N	Arm 16 Ahead	Inf	100.0 %	2120	2120
9/3 (M1 Northbound Offslip)	3.65	0.00	N	Arm 16 Ahead	Inf	100.0 %	2120	2120
9/4 (M1 Northbound Offslip)	3.65	0.00	N	Arm 16 Ahead	Inf	100.0 %	2120	2120
10/1	Infinite Saturation Flow						Inf	Inf
10/2	Infinite Saturation Flow						Inf	Inf
11/1	This lane uses a directly entered Saturation Flow						1900	1900
11/2	This lane uses a directly entered Saturation Flow						1900	1900
12/1 (Toucan Crossing)	3.80	0.00	Y	Arm 14 Ahead	Inf	100.0 %	1995	1995
12/2 (Toucan Crossing)	3.80	0.00	Y	Arm 14 Ahead	Inf	100.0 %	1995	1995
13/1 (A508 Northampton Rd)	3.65	0.00	Y	Arm 12 Ahead	Inf	100.0 %	1980	1980
13/2 (A508 Northampton Rd)	3.65	0.00	Y	Arm 12 Ahead	Inf	100.0 %	1980	1980
13/3 (A508 Northampton Rd)	3.65	0.00	N	Arm 17 Ahead	Inf	100.0 %	2120	2120
13/4 (A508 Northampton Rd)	3.65	0.00	N	Arm 17 Ahead	Inf	100.0 %	2120	2120
13/5 (A508 Northampton Rd)	3.65	0.00	N	Arm 17 Ahead	Inf	100.0 %	2120	2120
14/1	Infinite Saturation Flow						Inf	Inf
14/2	Infinite Saturation Flow						Inf	Inf
15/1	This lane uses a directly entered Saturation Flow						2000	2000
15/2	This lane uses a directly entered Saturation Flow						2000	2000
15/3	This lane uses a directly entered Saturation Flow						2000	2000
15/4	This lane uses a directly entered Saturation Flow						2000	2000
16/1	This lane uses a directly entered Saturation Flow						2000	2000
16/2	This lane uses a directly entered Saturation Flow						2000	2000
16/3	This lane uses a directly entered Saturation Flow						2000	2000
17/1	This lane uses a directly entered Saturation Flow						2000	2000
17/2	This lane uses a directly entered Saturation Flow						2000	2000
17/3	This lane uses a directly entered Saturation Flow						2000	2000
18/1	This lane uses a directly entered Saturation Flow						2000	2000
18/2	This lane uses a directly entered Saturation Flow						2000	2000
19/1	This lane uses a directly entered Saturation Flow						2000	2000
19/2	This lane uses a directly entered Saturation Flow						2120	2120
19/3	This lane uses a directly entered Saturation Flow						2120	2120

**Scenario 2: '2031 With additional mez - AM'** (FG3: '2031 with additional mez - AM', Plan 1: 'Network Control Plan 1')

**Traffic Flows, Desired**

**Desired Flow :**

	Destination						
	A	B	C	D	E	Tot.	
Origin	A	35	32	959	1142	1714	3882
	B	41	0	20	17	67	145
	C	1705	51	0	357	0	2113
	D	730	25	208	31	658	1652
	E	1230	116	0	807	3	2156
	Tot.	3741	224	1187	2354	2442	9948

## Traffic Lane Flows

Lane	Scenario 2: 2031 With additional mez - AM
<b>Junction: M1 Junction 15</b>	
1/1 (short)	379
1/2 (with short)	785(In) 406(Out)
1/3 (with short)	1371(In) 445(Out)
1/4 (short)	926
2/1	1309
2/2	1330
2/3	1102
3/1	296
3/2	104
3/3	319
3/4	522
4/1 (short)	493
4/2 (with short)	991(In) 498(Out)
4/3	956
4/4 (with short)	1935(In) 968(Out)
4/5 (short)	967
5/1	224
6/1	1275
6/2 (with short)	1533(In) 722(Out)
6/3 (short)	811
6/4	1049
7/1	585
7/2	602
8/1	63
8/2	82
9/1 (short)	357
9/2 (with short)	941(In) 584(Out)
9/3 (with short)	1172(In) 586(Out)
9/4 (short)	586
10/1	1632
10/2	722
11/1	913

11/2	947
12/1	1242
12/2	1200
13/1 (short)	329
13/2 (with short)	658(In) 329(Out)
13/3	311
13/4 (with short)	683(In) 338(Out)
13/5 (short)	345
14/1	1242
14/2	1200
15/1	930
15/2	924
15/3 (with short)	972(In) 657(Out)
15/4 (short)	315
16/1	584
16/2	586
16/3	586
17/1	346
17/2	338
17/3	386
18/1	565
18/2	602
19/1	1275
19/2	1490
19/3	967

## Lane Saturation Flows

Junction: M1 Junction 15								
Lane	Lane Width (m)	Gradient	Nearside Lane	Allowed Turns	Turning Radius (m)	Turning Prop.	Sat Flow (PCU/Hr)	Flared Sat Flow (PCU/Hr)
1/1 (M1 Southbound Offslip)	3.65	0.00	Y	Arm 2 Left	Inf	100.0 %	1980	1980
1/2 (M1 Southbound Offslip)	3.65	0.00	N	Arm 2 Left	Inf	100.0 %	2120	2120
1/3 (M1 Southbound Offslip)	3.65	0.00	N	Arm 2 Left	Inf	100.0 %	2120	2120
1/4 (M1 Southbound Offslip Lane 4)	This lane uses a directly entered Saturation Flow						4000	4000
2/1 (A45 Northbound Lane 1)	Infinite Saturation Flow						Inf	Inf
2/2 (A45 Northbound Lane 2)	Infinite Saturation Flow						Inf	Inf
2/3 (A45 Northbound Lane 3)	Infinite Saturation Flow						Inf	Inf
3/1	This lane uses a directly entered Saturation Flow						1900	1900
3/2	This lane uses a directly entered Saturation Flow						1900	1900
3/3	This lane uses a directly entered Saturation Flow						1900	1900
3/4	This lane uses a directly entered Saturation Flow						1900	1900
4/1 (A45 Southbound)	3.65	0.00	Y	Arm 5 Left	Inf	6.5 %	1980	1980
4/2 (A45 Southbound)				Arm 18 Ahead	Inf	93.5 %		
4/3 (A45 Southbound)	3.65	0.00	N	Arm 18 Ahead	Inf	100.0 %	2120	2120
4/4 (A45 Southbound)	3.65	0.00	N	Arm 19 Ahead	Inf	100.0 %	2120	2120
4/5 (A45 Southbound)	3.65	0.00	N	Arm 19 Ahead	Inf	100.0 %	2120	2120
5/1 (Saxon Avenue Exit Lane 1)	Infinite Saturation Flow						Inf	Inf
6/1 (M1 Northbound Circulatory Lane 1)	This lane uses a directly entered Saturation Flow						2120	2120
6/2 (M1 Northbound Circulatory Lane 2)	This lane uses a directly entered Saturation Flow						2120	2120
6/3 (M1 Northbound Circulatory Lane 3)	This lane uses a directly entered Saturation Flow						2120	2120
6/4 (M1 Northbound Circulatory Lane 4)	This lane uses a directly entered Saturation Flow						2120	2120
7/1 (M1 Southbound Onslip Lane 1)	Infinite Saturation Flow						Inf	Inf
7/2 (M1 Southbound Onslip Lane 2)	Infinite Saturation Flow						Inf	Inf

8/1 (Saxon Avenue)	3.50	0.00	Y	Arm 6 Left	Inf	68.3 %	1934	1934
				Arm 7 Left	30.00	31.7 %		
8/2 (Saxon Avenue)	3.50	0.00	N	Arm 6 Left	Inf	100.0 %	2105	2105
9/1 (M1 Northbound Offslip)	3.65	0.00	Y	Arm 10 Left	Inf	100.0 %	1980	1980
9/2 (M1 Northbound Offslip)	3.65	0.00	N	Arm 16 Ahead	Inf	100.0 %	2120	2120
9/3 (M1 Northbound Offslip)	3.65	0.00	N	Arm 16 Ahead	Inf	100.0 %	2120	2120
9/4 (M1 Northbound Offslip)	3.65	0.00	N	Arm 16 Ahead	Inf	100.0 %	2120	2120
10/1	Infinite Saturation Flow						Inf	Inf
10/2	Infinite Saturation Flow						Inf	Inf
11/1	This lane uses a directly entered Saturation Flow						1900	1900
11/2	This lane uses a directly entered Saturation Flow						1900	1900
12/1 (Toucan Crossing)	3.80	0.00	Y	Arm 14 Ahead	Inf	100.0 %	1995	1995
12/2 (Toucan Crossing)	3.80	0.00	Y	Arm 14 Ahead	Inf	100.0 %	1995	1995
13/1 (A508 Northampton Rd)	3.65	0.00	Y	Arm 12 Ahead	Inf	100.0 %	1980	1980
13/2 (A508 Northampton Rd)	3.65	0.00	Y	Arm 12 Ahead	Inf	100.0 %	1980	1980
13/3 (A508 Northampton Rd)	3.65	0.00	N	Arm 17 Ahead	Inf	100.0 %	2120	2120
13/4 (A508 Northampton Rd)	3.65	0.00	N	Arm 17 Ahead	Inf	100.0 %	2120	2120
13/5 (A508 Northampton Rd)	3.65	0.00	N	Arm 17 Ahead	Inf	100.0 %	2120	2120
14/1	Infinite Saturation Flow						Inf	Inf
14/2	Infinite Saturation Flow						Inf	Inf
15/1	This lane uses a directly entered Saturation Flow						2000	2000
15/2	This lane uses a directly entered Saturation Flow						2000	2000
15/3	This lane uses a directly entered Saturation Flow						2000	2000
15/4	This lane uses a directly entered Saturation Flow						2000	2000
16/1	This lane uses a directly entered Saturation Flow						2000	2000
16/2	This lane uses a directly entered Saturation Flow						2000	2000
16/3	This lane uses a directly entered Saturation Flow						2000	2000
17/1	This lane uses a directly entered Saturation Flow						2000	2000
17/2	This lane uses a directly entered Saturation Flow						2000	2000
17/3	This lane uses a directly entered Saturation Flow						2000	2000
18/1	This lane uses a directly entered Saturation Flow						2000	2000
18/2	This lane uses a directly entered Saturation Flow						2000	2000
19/1	This lane uses a directly entered Saturation Flow						2000	2000
19/2	This lane uses a directly entered Saturation Flow						2120	2120
19/3	This lane uses a directly entered Saturation Flow						2120	2120

**Scenario 3: '2031 Background - PM '** (FG2: '2031 background - PM', Plan 1: 'Network Control Plan 1')

**Traffic Flows, Desired**

**Desired Flow :**

	Destination						
	A	B	C	D	E	Tot.	
Origin	A	117	88	985	1199	1279	3668
	B	30	0	121	18	100	269
	C	1503	25	0	205	0	1733
	D	1440	13	199	50	709	2411
	E	1007	99	0	563	0	1669
	Tot.	4097	225	1305	2035	2088	9750

## Traffic Lane Flows

Lane	Scenario 3: 2031 Background - PM
<b>Junction: M1 Junction 15</b>	
1/1 (short)	292
1/2 (with short)	604(In) 312(Out)
1/3 (with short)	1065(In) 403(Out)
1/4 (short)	662
2/1	1443
2/2	1379
2/3	1275
3/1	246
3/2	90
3/3	261
3/4	352
4/1 (short)	534
4/2 (with short)	1073(In) 539(Out)
4/3	865
4/4 (with short)	1730(In) 684(Out)
4/5 (short)	1046
5/1	225
6/1	1126
6/2 (with short)	1054(In) 704(Out)
6/3 (short)	350
6/4	1176
7/1	676
7/2	629
8/1	139
8/2	130
9/1 (short)	205
9/2 (with short)	697(In) 492(Out)
9/3 (with short)	1036(In) 477(Out)
9/4 (short)	559
10/1	1331
10/2	704
11/1	687

11/2	839
12/1	1041
12/2	1047
13/1 (short)	354
13/2 (with short)	709(In) 355(Out)
13/3	540
13/4 (with short)	1162(In) 564(Out)
13/5 (short)	598
14/1	1041
14/2	1047
15/1	1151
15/2	1067
15/3 (with short)	1159(In) 872(Out)
15/4 (short)	287
16/1	492
16/2	477
16/3	559
17/1	659
17/2	590
17/3	600
18/1	555
18/2	629
19/1	1126
19/2	1036
19/3	1046

## Lane Saturation Flows

Junction: M1 Junction 15								
Lane	Lane Width (m)	Gradient	Nearside Lane	Allowed Turns	Turning Radius (m)	Turning Prop.	Sat Flow (PCU/Hr)	Flared Sat Flow (PCU/Hr)
1/1 (M1 Southbound Offslip)	3.65	0.00	Y	Arm 2 Left	Inf	100.0 %	1980	1980
1/2 (M1 Southbound Offslip)	3.65	0.00	N	Arm 2 Left	Inf	100.0 %	2120	2120
1/3 (M1 Southbound Offslip)	3.65	0.00	N	Arm 2 Left	Inf	100.0 %	2120	2120
1/4 (M1 Southbound Offslip Lane 4)	This lane uses a directly entered Saturation Flow						4000	4000
2/1 (A45 Northbound Lane 1)	Infinite Saturation Flow						Inf	Inf
2/2 (A45 Northbound Lane 2)	Infinite Saturation Flow						Inf	Inf
2/3 (A45 Northbound Lane 3)	Infinite Saturation Flow						Inf	Inf
3/1	This lane uses a directly entered Saturation Flow						1900	1900
3/2	This lane uses a directly entered Saturation Flow						1900	1900
3/3	This lane uses a directly entered Saturation Flow						1900	1900
3/4	This lane uses a directly entered Saturation Flow						1900	1900
4/1 (A45 Southbound)	3.65	0.00	Y	Arm 5 Left	Inf	16.5 %	1980	1980
4/2 (A45 Southbound)				Arm 18 Ahead	Inf	83.5 %		
4/3 (A45 Southbound)	3.65	0.00	N	Arm 18 Ahead	Inf	100.0 %	2120	2120
4/4 (A45 Southbound)	3.65	0.00	N	Arm 19 Ahead	Inf	100.0 %	2120	2120
4/5 (A45 Southbound)	3.65	0.00	N	Arm 19 Ahead	Inf	100.0 %	2120	2120
5/1 (Saxon Avenue Exit Lane 1)	Infinite Saturation Flow						Inf	Inf
6/1 (M1 Northbound Circulatory Lane 1)	This lane uses a directly entered Saturation Flow						2120	2120
6/2 (M1 Northbound Circulatory Lane 2)	This lane uses a directly entered Saturation Flow						2120	2120
6/3 (M1 Northbound Circulatory Lane 3)	This lane uses a directly entered Saturation Flow						2120	2120
6/4 (M1 Northbound Circulatory Lane 4)	This lane uses a directly entered Saturation Flow						2120	2120
7/1 (M1 Southbound Onslip Lane 1)	Infinite Saturation Flow						Inf	Inf
7/2 (M1 Southbound Onslip Lane 2)	Infinite Saturation Flow						Inf	Inf

8/1 (Saxon Avenue)	3.50	0.00	Y	Arm 6 Left	Inf	12.9 %	1883	1883
				Arm 7 Left	30.00	87.1 %		
8/2 (Saxon Avenue)	3.50	0.00	N	Arm 6 Left	Inf	100.0 %	2105	2105
9/1 (M1 Northbound Offslip)	3.65	0.00	Y	Arm 10 Left	Inf	100.0 %	1980	1980
9/2 (M1 Northbound Offslip)	3.65	0.00	N	Arm 16 Ahead	Inf	100.0 %	2120	2120
9/3 (M1 Northbound Offslip)	3.65	0.00	N	Arm 16 Ahead	Inf	100.0 %	2120	2120
9/4 (M1 Northbound Offslip)	3.65	0.00	N	Arm 16 Ahead	Inf	100.0 %	2120	2120
10/1	Infinite Saturation Flow						Inf	Inf
10/2	Infinite Saturation Flow						Inf	Inf
11/1	This lane uses a directly entered Saturation Flow						1900	1900
11/2	This lane uses a directly entered Saturation Flow						1900	1900
12/1 (Toucan Crossing)	3.80	0.00	Y	Arm 14 Ahead	Inf	100.0 %	1995	1995
12/2 (Toucan Crossing)	3.80	0.00	Y	Arm 14 Ahead	Inf	100.0 %	1995	1995
13/1 (A508 Northampton Rd)	3.65	0.00	Y	Arm 12 Ahead	Inf	100.0 %	1980	1980
13/2 (A508 Northampton Rd)	3.65	0.00	Y	Arm 12 Ahead	Inf	100.0 %	1980	1980
13/3 (A508 Northampton Rd)	3.65	0.00	N	Arm 17 Ahead	Inf	100.0 %	2120	2120
13/4 (A508 Northampton Rd)	3.65	0.00	N	Arm 17 Ahead	Inf	100.0 %	2120	2120
13/5 (A508 Northampton Rd)	3.65	0.00	N	Arm 17 Ahead	Inf	100.0 %	2120	2120
14/1	Infinite Saturation Flow						Inf	Inf
14/2	Infinite Saturation Flow						Inf	Inf
15/1	This lane uses a directly entered Saturation Flow						2000	2000
15/2	This lane uses a directly entered Saturation Flow						2000	2000
15/3	This lane uses a directly entered Saturation Flow						2000	2000
15/4	This lane uses a directly entered Saturation Flow						2000	2000
16/1	This lane uses a directly entered Saturation Flow						2000	2000
16/2	This lane uses a directly entered Saturation Flow						2000	2000
16/3	This lane uses a directly entered Saturation Flow						2000	2000
17/1	This lane uses a directly entered Saturation Flow						2000	2000
17/2	This lane uses a directly entered Saturation Flow						2000	2000
17/3	This lane uses a directly entered Saturation Flow						2000	2000
18/1	This lane uses a directly entered Saturation Flow						2000	2000
18/2	This lane uses a directly entered Saturation Flow						2000	2000
19/1	This lane uses a directly entered Saturation Flow						2000	2000
19/2	This lane uses a directly entered Saturation Flow						2120	2120
19/3	This lane uses a directly entered Saturation Flow						2120	2120

**Scenario 4: '2031 With additional mez - PM '** (FG4: '2031 with additional mez - PM', Plan 1: 'Network Control Plan 1')

**Traffic Flows, Desired**

**Desired Flow :**

		Destination					
		A	B	C	D	E	Tot.
Origin	A	117	88	985	1219	1279	3688
	B	30	0	121	18	100	269
	C	1503	25	0	215	0	1743
	D	1491	13	222	50	729	2505
	E	1007	99	0	577	0	1683
	Tot.	4148	225	1328	2079	2108	9888

## Traffic Lane Flows

Lane	Scenario 4: 2031 With additional mez - PM
<b>Junction: M1 Junction 15</b>	
1/1 (short)	293
1/2 (with short)	607(In) 314(Out)
1/3 (with short)	1076(In) 400(Out)
1/4 (short)	676
2/1	1476
2/2	1411
2/3	1261
3/1	257
3/2	102
3/3	274
3/4	353
4/1 (short)	534
4/2 (with short)	1073(In) 539(Out)
4/3	866
4/4 (with short)	1749(In) 702(Out)
4/5 (short)	1047
5/1	225
6/1	1140
6/2 (with short)	1073(In) 724(Out)
6/3 (short)	349
6/4	1177
7/1	687
7/2	641
8/1	139
8/2	130
9/1 (short)	215
9/2 (with short)	707(In) 492(Out)
9/3 (with short)	1036(In) 479(Out)
9/4 (short)	557
10/1	1355
10/2	724
11/1	687

11/2	839
12/1	1052
12/2	1056
13/1 (short)	365
13/2 (with short)	729(In) 364(Out)
13/3	574
13/4 (with short)	1202(In) 588(Out)
13/5 (short)	614
14/1	1052
14/2	1056
15/1	1183
15/2	1097
15/3 (with short)	1171(In) 861(Out)
15/4 (short)	310
16/1	492
16/2	479
16/3	557
17/1	691
17/2	618
17/3	614
18/1	566
18/2	641
19/1	1140
19/2	1055
19/3	1047

## Lane Saturation Flows

Junction: M1 Junction 15								
Lane	Lane Width (m)	Gradient	Nearside Lane	Allowed Turns	Turning Radius (m)	Turning Prop.	Sat Flow (PCU/Hr)	Flared Sat Flow (PCU/Hr)
1/1 (M1 Southbound Offslip)	3.65	0.00	Y	Arm 2 Left	Inf	100.0 %	1980	1980
1/2 (M1 Southbound Offslip)	3.65	0.00	N	Arm 2 Left	Inf	100.0 %	2120	2120
1/3 (M1 Southbound Offslip)	3.65	0.00	N	Arm 2 Left	Inf	100.0 %	2120	2120
1/4 (M1 Southbound Offslip Lane 4)	This lane uses a directly entered Saturation Flow						4000	4000
2/1 (A45 Northbound Lane 1)	Infinite Saturation Flow						Inf	Inf
2/2 (A45 Northbound Lane 2)	Infinite Saturation Flow						Inf	Inf
2/3 (A45 Northbound Lane 3)	Infinite Saturation Flow						Inf	Inf
3/1	This lane uses a directly entered Saturation Flow						1900	1900
3/2	This lane uses a directly entered Saturation Flow						1900	1900
3/3	This lane uses a directly entered Saturation Flow						1900	1900
3/4	This lane uses a directly entered Saturation Flow						1900	1900
4/1 (A45 Southbound)	3.65	0.00	Y	Arm 5 Left	Inf	16.5 %	1980	1980
				Arm 18 Ahead	Inf	83.5 %		
4/2 (A45 Southbound)	3.65	0.00	N	Arm 18 Ahead	Inf	100.0 %	2120	2120
4/3 (A45 Southbound)	3.65	0.00	N	Arm 19 Ahead	Inf	100.0 %	2120	2120
4/4 (A45 Southbound)	3.65	0.00	N	Arm 19 Ahead	Inf	100.0 %	2120	2120
4/5 (A45 Southbound)	3.65	0.00	N	Arm 19 Ahead	Inf	100.0 %	2120	2120
5/1 (Saxon Avenue Exit Lane 1)	Infinite Saturation Flow						Inf	Inf
6/1 (M1 Northbound Circulatory Lane 1)	This lane uses a directly entered Saturation Flow						2120	2120
6/2 (M1 Northbound Circulatory Lane 2)	This lane uses a directly entered Saturation Flow						2120	2120
6/3 (M1 Northbound Circulatory Lane 3)	This lane uses a directly entered Saturation Flow						2120	2120
6/4 (M1 Northbound Circulatory Lane 4)	This lane uses a directly entered Saturation Flow						2120	2120
7/1 (M1 Southbound Onslip Lane 1)	Infinite Saturation Flow						Inf	Inf
7/2 (M1 Southbound Onslip Lane 2)	Infinite Saturation Flow						Inf	Inf

8/1 (Saxon Avenue)	3.50	0.00	Y	Arm 6 Left	Inf	12.9 %	1883	1883
				Arm 7 Left	30.00	87.1 %		
8/2 (Saxon Avenue)	3.50	0.00	N	Arm 6 Left	Inf	100.0 %	2105	2105
9/1 (M1 Northbound Offslip)	3.65	0.00	Y	Arm 10 Left	Inf	100.0 %	1980	1980
9/2 (M1 Northbound Offslip)	3.65	0.00	N	Arm 16 Ahead	Inf	100.0 %	2120	2120
9/3 (M1 Northbound Offslip)	3.65	0.00	N	Arm 16 Ahead	Inf	100.0 %	2120	2120
9/4 (M1 Northbound Offslip)	3.65	0.00	N	Arm 16 Ahead	Inf	100.0 %	2120	2120
10/1	Infinite Saturation Flow						Inf	Inf
10/2	Infinite Saturation Flow						Inf	Inf
11/1	This lane uses a directly entered Saturation Flow						1900	1900
11/2	This lane uses a directly entered Saturation Flow						1900	1900
12/1 (Toucan Crossing)	3.80	0.00	Y	Arm 14 Ahead	Inf	100.0 %	1995	1995
12/2 (Toucan Crossing)	3.80	0.00	Y	Arm 14 Ahead	Inf	100.0 %	1995	1995
13/1 (A508 Northampton Rd)	3.65	0.00	Y	Arm 12 Ahead	Inf	100.0 %	1980	1980
13/2 (A508 Northampton Rd)	3.65	0.00	Y	Arm 12 Ahead	Inf	100.0 %	1980	1980
13/3 (A508 Northampton Rd)	3.65	0.00	N	Arm 17 Ahead	Inf	100.0 %	2120	2120
13/4 (A508 Northampton Rd)	3.65	0.00	N	Arm 17 Ahead	Inf	100.0 %	2120	2120
13/5 (A508 Northampton Rd)	3.65	0.00	N	Arm 17 Ahead	Inf	100.0 %	2120	2120
14/1	Infinite Saturation Flow						Inf	Inf
14/2	Infinite Saturation Flow						Inf	Inf
15/1	This lane uses a directly entered Saturation Flow						2000	2000
15/2	This lane uses a directly entered Saturation Flow						2000	2000
15/3	This lane uses a directly entered Saturation Flow						2000	2000
15/4	This lane uses a directly entered Saturation Flow						2000	2000
16/1	This lane uses a directly entered Saturation Flow						2000	2000
16/2	This lane uses a directly entered Saturation Flow						2000	2000
16/3	This lane uses a directly entered Saturation Flow						2000	2000
17/1	This lane uses a directly entered Saturation Flow						2000	2000
17/2	This lane uses a directly entered Saturation Flow						2000	2000
17/3	This lane uses a directly entered Saturation Flow						2000	2000
18/1	This lane uses a directly entered Saturation Flow						2000	2000
18/2	This lane uses a directly entered Saturation Flow						2000	2000
19/1	This lane uses a directly entered Saturation Flow						2000	2000
19/2	This lane uses a directly entered Saturation Flow						2120	2120
19/3	This lane uses a directly entered Saturation Flow						2120	2120

**Scenario 1: '2031 Background - AM'** (FG1: '2031 background - AM', Plan 1: 'Network Control Plan 1')

**C1 - Eastside Controller**

**Stage Sequence Diagram**

**Stage Stream: 1**

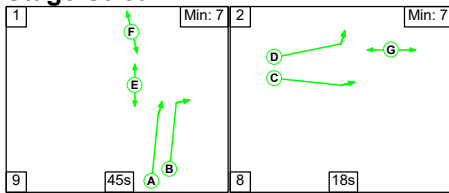

**Stage Stream: 2**

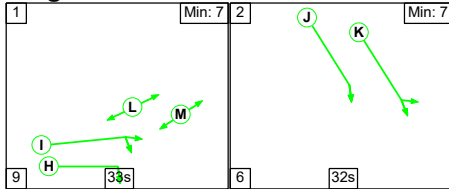

**Stage Stream: 3**

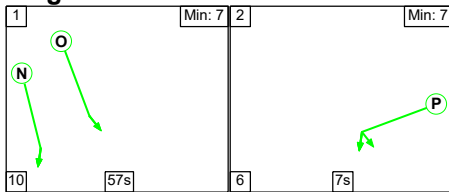

**Stage Timings**

**Stage Stream: 1**

Stage	1	2
Duration	45	18
Change Point	67	41

**Stage Stream: 2**

Stage	1	2
Duration	33	32
Change Point	30	72

**Stage Stream: 3**

Stage	1	2
Duration	57	7
Change Point	47	34

# Signal Timings Diagram

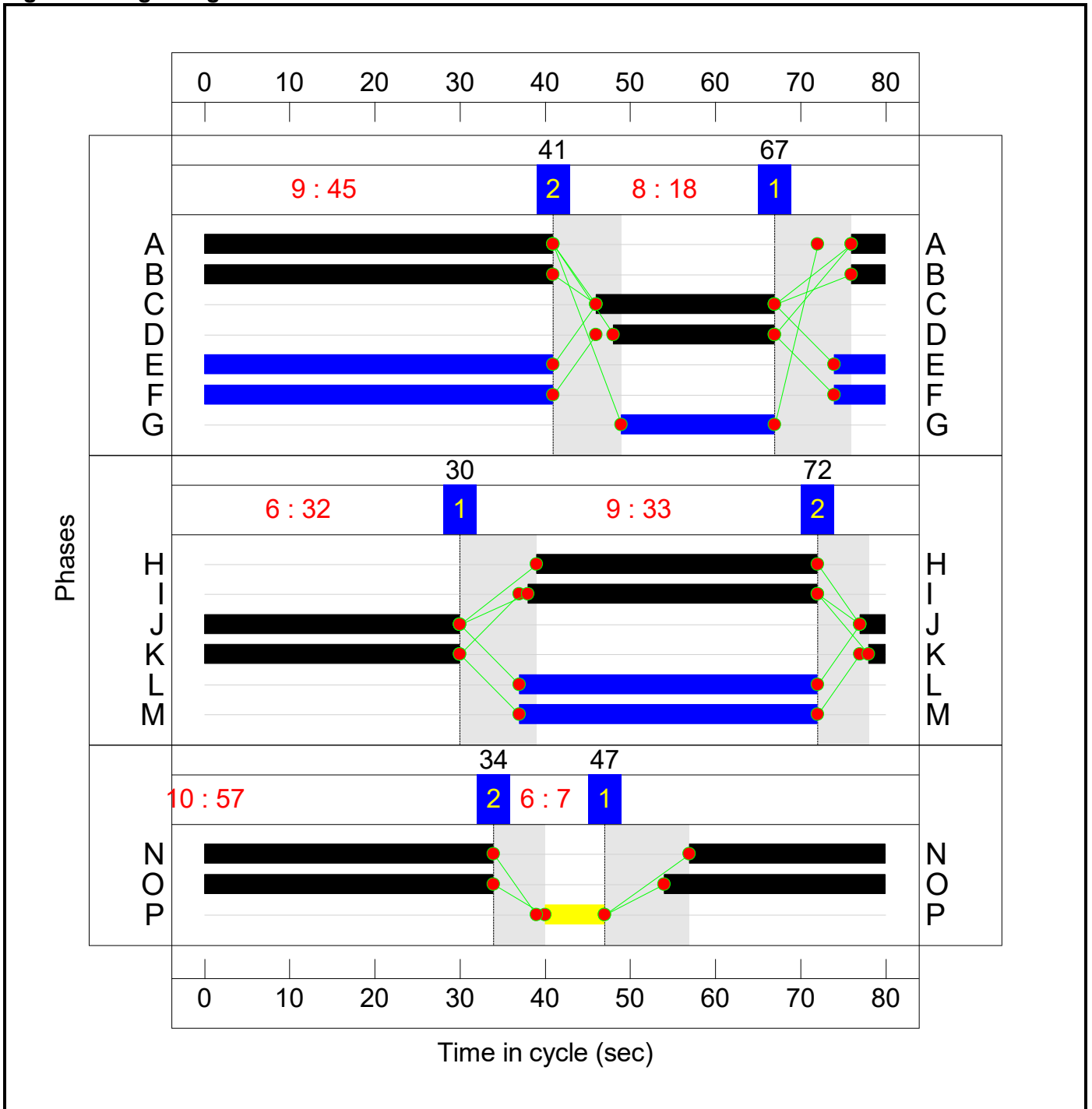

## C2 - Westside Controller Stage Sequence Diagram Stage Stream: 1

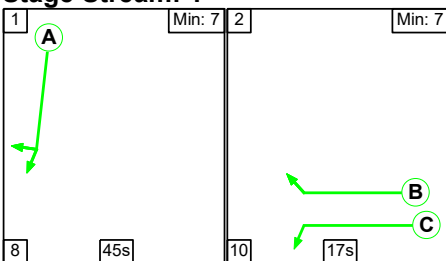

### Stage Stream: 2

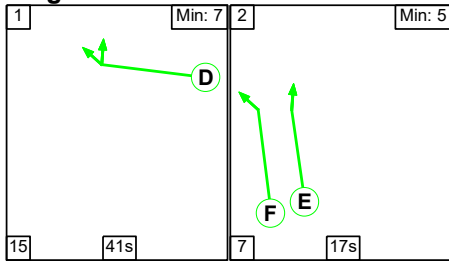

### Stage Stream: 3

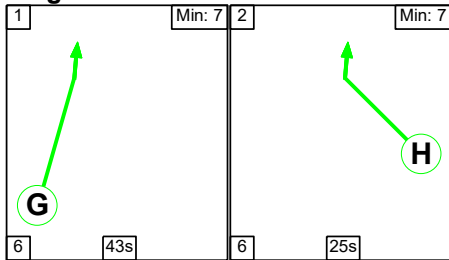

### Stage Stream: 4

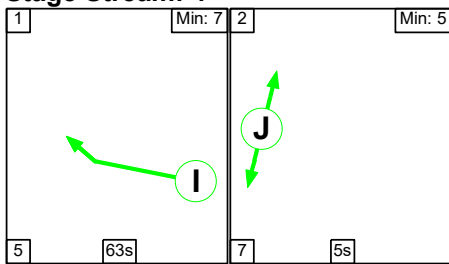

### Stage Timings

#### Stage Stream: 1

Stage	1	2
Duration	45	17
Change Point	24	77

#### Stage Stream: 2

Stage	1	2
Duration	41	17
Change Point	6	62

#### Stage Stream: 3

Stage	1	2
Duration	43	25
Change Point	35	4

#### Stage Stream: 4

Stage	1	2
Duration	63	5
Change Point	16	4

# Signal Timings Diagram

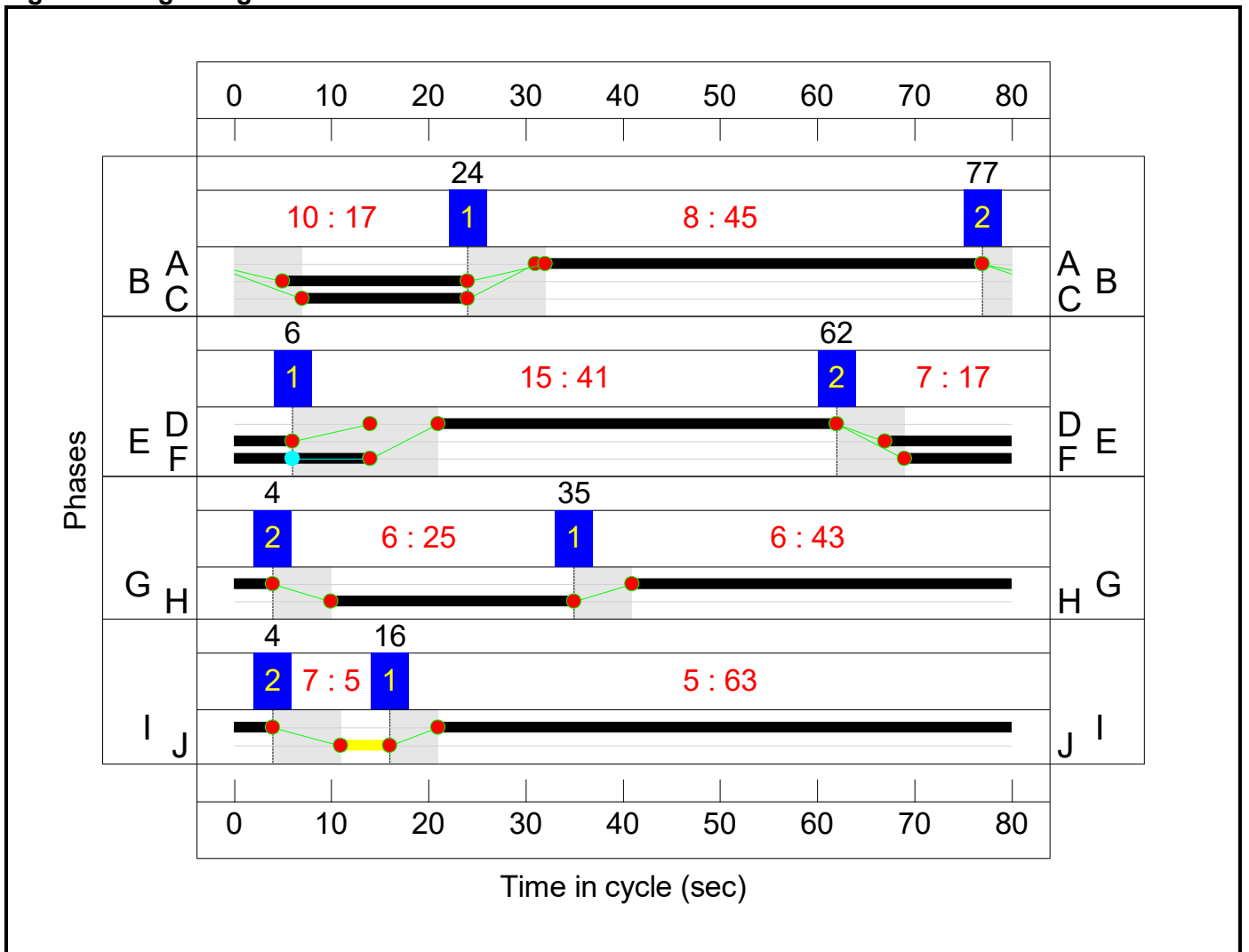

## Network Results

Item	Lane Description	Lane Type	Controller Stream	Position In Filtered Route	Full Phase	Arrow Phase	Num Greens	Total Green (s)	Arrow Green (s)	Demand Flow (pcu)	Sat Flow (pcu/Hr)	Capacity (pcu)	Deg Sat (%)
<b>Network: M1 Junction 15 impact with additional mezzanine</b>	-	-	<b>N/A</b>	-	-		-	-	-	-	-	-	<b>110.6%</b>
<b>M1 Junction 15</b>	-	-	<b>N/A</b>	-	-		-	-	-	-	-	-	<b>110.6%</b>
1/2+1/1	M1 Southbound Offslip Left	U	1:1	N/A	C1:D		1	19	-	779	2120:1980	530+495	76.0 : 76.0%
1/3+1/4	M1 Southbound Offslip Left Ahead	U	1:1	N/A	C1:D C1:C		1	19:21	-	1354	2120:4000	530+1100	85.1 : 82.1%
3/1	Ahead Right	U	1:2	N/A	C1:I		1	34	-	291	1900	831	34.4%
3/2	Right	U	1:2	N/A	C1:I		1	34	-	99	1900	831	11.9%
3/3	Right	U	1:2	N/A	C1:H		1	33	-	319	1900	808	39.5%
3/4	Right	U	1:2	N/A	C1:H		1	33	-	499	1900	808	61.8%
4/2+4/1	A45 Southbound Left Ahead	U	1:2	N/A	C1:K		1	32	-	991	2120:1980	875+817	56.9 : 60.4%
4/3	A45 Southbound Ahead	U	1:2	N/A	C1:J		1	33	-	944	2120	901	104.8%
4/4+4/5	A45 Southbound Ahead	U	1:2	N/A	C1:J		1	33	-	1910	2120:2120	901+901	106.1 : 105.9%
6/1	M1 Northbound Circulatory Ahead	U	2:1	N/A	C2:A		1	45	-	1263	2120	1219	100.1%
6/2+6/3	M1 Northbound Circulatory Ahead Right	U	2:1	N/A	C2:A		1	45	-	1503	2120:2120	673+828	98.8 : 94.6%
6/4	M1 Northbound Circulatory Right	U	2:1	N/A	C2:A		1	45	-	1031	2120	1219	80.2%
8/1	Saxon Avenue Left Left2	U	1:3	N/A	C1:P		1	7	-	68	1937	194	35.1%
8/2	Saxon Avenue Left	U	1:3	N/A	C1:P		1	7	-	77	2105	210	36.6%
9/2+9/1	M1 Northbound Offslip Left Ahead	U	2:1	N/A	C2:B C2:C		1	19:17	-	914	2120:1980	530+299	110.2 : 110.2%

9/3+9/4	M1 Northbound Offslip Ahead	U	2:1	N/A	C2:B		1	19	-	1172	2120:2120	530+530	110.6 : 110.6%
11/1	Ahead	U	2:2	N/A	C2:D		1	41	-	900	1900	997	85.3%
11/2	Ahead Right	U	2:2	N/A	C2:D		1	41	-	960	1900	997	91.3%
12/1	Toucan Crossing Ahead	U	2:4	N/A	C2:I		1	63	-	1224	1995	1596	73.6%
12/2	Toucan Crossing Ahead	U	2:4	N/A	C2:I		1	63	-	1209	1995	1596	72.8%
13/2+13/1	A508 Northampton Rd Ahead	U	2:2	N/A	C2:F		1	25	-	649	1980:1980	549+547	59.2 : 59.2%
13/3	A508 Northampton Rd Ahead	U	2:2	N/A	C2:E		1	19	-	304	2120	530	57.4%
13/4+13/5	A508 Northampton Rd Ahead	U	2:2	N/A	C2:E		1	19	-	665	2120:2120	530+530	62.1 : 63.4%
15/1	Ahead	U	1:1	N/A	C1:A		1	45	-	923	2000	1150	75.4%
15/2	Ahead	U	1:1	N/A	C1:A		1	45	-	915	2000	1150	74.7%
15/3+15/4	Ahead Right	U	1:1	N/A	C1:A C1:B		1	45	-	963	2000:2000	941+436	64.5 : 68.8%
16/1	Right	U	2:3	N/A	C2:H		1	25	-	584	2000	650	81.5%
16/2	Right	U	2:3	N/A	C2:H		1	25	-	586	2000	650	81.5%
16/3	Right	U	2:3	N/A	C2:H		1	25	-	586	2000	650	81.5%
17/1	Ahead	U	2:3	N/A	C2:G		1	43	-	339	2000	1100	30.6%
17/2	Ahead	U	2:3	N/A	C2:G		1	43	-	329	2000	1100	29.9%
17/3	Ahead	U	2:3	N/A	C2:G		1	43	-	377	2000	1100	34.3%
18/1	Ahead	U	1:3	N/A	C1:O		1	60	-	560	2000	1525	36.7%
18/2	Ahead	U	1:3	N/A	C1:O		1	60	-	597	2000	1525	39.1%
19/1	Ahead	U	1:3	N/A	C1:N		1	57	-	1263	2000	1450	84.1%
19/2	Ahead	U	1:3	N/A	C1:N		1	57	-	1455	2120	1537	91.1%
19/3	Ahead	U	1:3	N/A	C1:N		1	57	-	954	2120	1537	58.6%

Item	Arriving (pcu)	Leaving (pcu)	Turners In Gaps (pcu)	Turners When Unopposed (pcu)	Turners In Intergreen (pcu)	Uniform Delay (pcuHr)	Rand + Oversat Delay (pcuHr)	Storage Area Uniform Delay (pcuHr)	Total Delay (pcuHr)	Av. Delay Per PCU (s/pcu)	Max. Back of Uniform Queue (pcu)	Rand + Oversat Queue (pcu)	Mean Max Queue (pcu)
<b>Network: M1 Junction 15 impact with additional mezzanine</b>	-	-	0	0	0	114.1	207.1	0.0	321.2	-	-	-	-
<b>M1 Junction 15</b>	-	-	0	0	0	114.1	207.1	0.0	321.2	-	-	-	-
1/2+1/1	779	779	-	-	-	6.0	1.6	-	7.6 (3.9+3.7)	35.0 (35.0:35.0)	8.3	1.6	9.8
1/3+1/4	1354	1354	-	-	-	10.4	2.4	-	12.8 (4.4+8.4)	34.0 (35.0:33.6)	9.5	2.4	11.9
3/1	286	286	-	-	-	1.1	0.0	-	1.1	14.3	3.8	0.0	3.8
3/2	99	99	-	-	-	0.8	0.0	-	0.8	28.9	2.2	0.0	2.2
3/3	319	319	-	-	-	0.2	0.0	-	0.2	2.8	0.7	0.0	0.7
3/4	499	499	-	-	-	0.2	0.0	-	0.2	1.4	5.0	0.0	5.0
4/2+4/1	991	991	-	-	-	5.0	0.7	-	5.7 (2.9+2.9)	20.8 (20.6:21.0)	8.5	0.7	9.2
4/3	944	901	-	-	-	7.8	29.5	-	37.3	142.1	21.9	29.5	51.4
4/4+4/5	1910	1802	-	-	-	16.5	61.7	-	78.3 (39.7+38.6)	147.5 (149.4:145.6)	22.5	61.7	84.2
6/1	1220	1219	-	-	-	6.8	0.5	-	7.3	21.5	22.2	0.5	22.7
6/2+6/3	1448	1448	-	-	-	6.8	0.0	-	6.8 (3.3+3.6)	17.0 (17.6:16.5)	18.9	0.0	18.9
6/4	978	978	-	-	-	4.9	0.0	-	4.9	18.1	21.1	0.0	21.1
8/1	68	68	-	-	-	0.6	0.3	-	0.9	47.9	1.4	0.3	1.7
8/2	77	77	-	-	-	0.7	0.3	-	1.0	47.1	1.6	0.3	1.9
9/2+9/1	914	860	-	-	-	9.7	47.1	-	56.8 (37.1+19.7)	223.6 (228.8:214.4)	14.2	47.1	61.3
9/3+9/4	1172	1060	-	-	-	14.2	60.8	-	75.0 (37.5+37.5)	230.5 (230.5:230.5)	14.3	60.8	75.1
11/1	851	851	-	-	-	3.1	0.0	-	3.1	13.2	9.6	0.0	9.6
11/2	911	911	-	-	-	3.5	0.0	-	3.5	14.0	7.0	0.0	7.0
12/1	1175	1175	-	-	-	0.1	0.0	-	0.1	0.5	1.1	0.0	1.1

12/2	1162	1162	-	-	-	0.1	0.0	-	0.1	0.5	1.1	0.0	1.1																																																								
13/2+13/1	649	649	-	-	-	3.9	0.7	-	4.7 (2.3+2.3)	25.8 (25.8:25.8)	5.8	0.7	6.5																																																								
13/3	304	304	-	-	-	2.2	0.7	-	2.9	34.2	5.9	0.7	6.6																																																								
13/4+13/5	665	665	-	-	-	4.9	0.8	-	5.8 (2.8+2.9)	31.2 (31.2:31.3)	6.6	0.8	7.5																																																								
15/1	867	867	-	-	-	0.3	0.0	-	0.3	1.4	1.3	0.0	1.3																																																								
15/2	859	859	-	-	-	0.2	0.0	-	0.2	0.9	0.6	0.0	0.6																																																								
15/3+15/4	907	907	-	-	-	0.5	0.0	-	0.5 (0.3+0.2)	2.0 (2.0:1.9)	1.1	0.0	1.1																																																								
16/1	530	530	-	-	-	0.1	0.0	-	0.1	0.6	0.7	0.0	0.7																																																								
16/2	530	530	-	-	-	0.1	0.0	-	0.1	0.6	0.7	0.0	0.7																																																								
16/3	530	530	-	-	-	0.1	0.0	-	0.1	0.6	0.7	0.0	0.7																																																								
17/1	337	337	-	-	-	0.3	0.0	-	0.3	3.2	0.8	0.0	0.8																																																								
17/2	329	329	-	-	-	0.3	0.0	-	0.3	3.2	0.6	0.0	0.6																																																								
17/3	377	377	-	-	-	0.4	0.0	-	0.4	3.5	1.6	0.0	1.6																																																								
18/1	560	560	-	-	-	0.3	0.0	-	0.3	1.9	2.3	0.0	2.3																																																								
18/2	597	597	-	-	-	0.4	0.0	-	0.4	2.2	2.3	0.0	2.3																																																								
19/1	1220	1220	-	-	-	1.0	0.0	-	1.0	2.8	5.2	0.0	5.2																																																								
19/2	1400	1400	-	-	-	0.2	0.0	-	0.2	0.5	0.6	0.0	0.6																																																								
19/3	901	901	-	-	-	0.2	0.0	-	0.2	0.6	0.6	0.0	0.6																																																								
<table border="0"> <tbody> <tr> <td>C1 - Eastside Controller</td><td>Stream: 1 PRC for Signalled Lanes (%)</td><td>5.8</td><td>Total Delay for Signalled Lanes (pcuHr):</td><td>21.43</td><td>Cycle Time (s):</td><td>80</td></tr> <tr> <td>C1 - Eastside Controller</td><td>Stream: 2 PRC for Signalled Lanes (%)</td><td>-17.9</td><td>Total Delay for Signalled Lanes (pcuHr):</td><td>123.62</td><td>Cycle Time (s):</td><td>80</td></tr> <tr> <td>C1 - Eastside Controller</td><td>Stream: 3 PRC for Signalled Lanes (%)</td><td>-1.2</td><td>Total Delay for Signalled Lanes (pcuHr):</td><td>3.88</td><td>Cycle Time (s):</td><td>80</td></tr> <tr> <td>C2 - Westside Controller</td><td>Stream: 1 PRC for Signalled Lanes (%)</td><td>-22.9</td><td>Total Delay for Signalled Lanes (pcuHr):</td><td>150.85</td><td>Cycle Time (s):</td><td>80</td></tr> <tr> <td>C2 - Westside Controller</td><td>Stream: 2 PRC for Signalled Lanes (%)</td><td>-1.4</td><td>Total Delay for Signalled Lanes (pcuHr):</td><td>19.95</td><td>Cycle Time (s):</td><td>80</td></tr> <tr> <td>C2 - Westside Controller</td><td>Stream: 3 PRC for Signalled Lanes (%)</td><td>10.4</td><td>Total Delay for Signalled Lanes (pcuHr):</td><td>1.23</td><td>Cycle Time (s):</td><td>80</td></tr> <tr> <td>C2 - Westside Controller</td><td>Stream: 4 PRC for Signalled Lanes (%)</td><td>22.3</td><td>Total Delay for Signalled Lanes (pcuHr):</td><td>0.30</td><td>Cycle Time (s):</td><td>80</td></tr> <tr> <td></td><td>PRC Over All Lanes (%)</td><td>-22.9</td><td>Total Delay Over All Lanes(pcuHr):</td><td>321.25</td><td></td><td></td></tr> </tbody> </table>														C1 - Eastside Controller	Stream: 1 PRC for Signalled Lanes (%)	5.8	Total Delay for Signalled Lanes (pcuHr):	21.43	Cycle Time (s):	80	C1 - Eastside Controller	Stream: 2 PRC for Signalled Lanes (%)	-17.9	Total Delay for Signalled Lanes (pcuHr):	123.62	Cycle Time (s):	80	C1 - Eastside Controller	Stream: 3 PRC for Signalled Lanes (%)	-1.2	Total Delay for Signalled Lanes (pcuHr):	3.88	Cycle Time (s):	80	C2 - Westside Controller	Stream: 1 PRC for Signalled Lanes (%)	-22.9	Total Delay for Signalled Lanes (pcuHr):	150.85	Cycle Time (s):	80	C2 - Westside Controller	Stream: 2 PRC for Signalled Lanes (%)	-1.4	Total Delay for Signalled Lanes (pcuHr):	19.95	Cycle Time (s):	80	C2 - Westside Controller	Stream: 3 PRC for Signalled Lanes (%)	10.4	Total Delay for Signalled Lanes (pcuHr):	1.23	Cycle Time (s):	80	C2 - Westside Controller	Stream: 4 PRC for Signalled Lanes (%)	22.3	Total Delay for Signalled Lanes (pcuHr):	0.30	Cycle Time (s):	80		PRC Over All Lanes (%)	-22.9	Total Delay Over All Lanes(pcuHr):	321.25		
C1 - Eastside Controller	Stream: 1 PRC for Signalled Lanes (%)	5.8	Total Delay for Signalled Lanes (pcuHr):	21.43	Cycle Time (s):	80																																																															
C1 - Eastside Controller	Stream: 2 PRC for Signalled Lanes (%)	-17.9	Total Delay for Signalled Lanes (pcuHr):	123.62	Cycle Time (s):	80																																																															
C1 - Eastside Controller	Stream: 3 PRC for Signalled Lanes (%)	-1.2	Total Delay for Signalled Lanes (pcuHr):	3.88	Cycle Time (s):	80																																																															
C2 - Westside Controller	Stream: 1 PRC for Signalled Lanes (%)	-22.9	Total Delay for Signalled Lanes (pcuHr):	150.85	Cycle Time (s):	80																																																															
C2 - Westside Controller	Stream: 2 PRC for Signalled Lanes (%)	-1.4	Total Delay for Signalled Lanes (pcuHr):	19.95	Cycle Time (s):	80																																																															
C2 - Westside Controller	Stream: 3 PRC for Signalled Lanes (%)	10.4	Total Delay for Signalled Lanes (pcuHr):	1.23	Cycle Time (s):	80																																																															
C2 - Westside Controller	Stream: 4 PRC for Signalled Lanes (%)	22.3	Total Delay for Signalled Lanes (pcuHr):	0.30	Cycle Time (s):	80																																																															
	PRC Over All Lanes (%)	-22.9	Total Delay Over All Lanes(pcuHr):	321.25																																																																	

Scenario 2: '2031 With additional mez - AM' (FG3: '2031 with additional mez - AM', Plan 1: 'Network Control Plan 1')

C1 - Eastside Controller

Stage Sequence Diagram

Stage Stream: 1

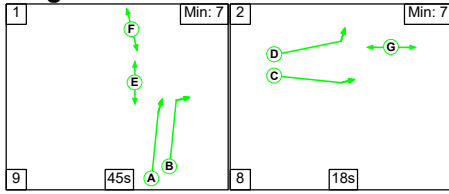

Stage Stream: 2

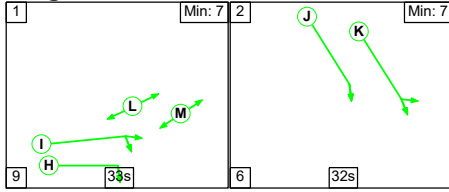

Stage Stream: 3

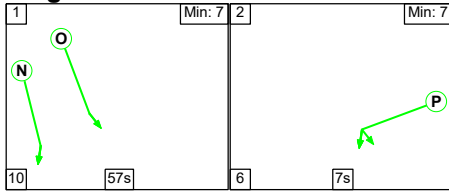

Stage Timings

Stage Stream: 1

Stage	1	2
Duration	45	18
Change Point	67	41

Stage Stream: 2

Stage	1	2
Duration	33	32
Change Point	30	72

Stage Stream: 3

Stage	1	2
Duration	57	7
Change Point	47	34

# Signal Timings Diagram

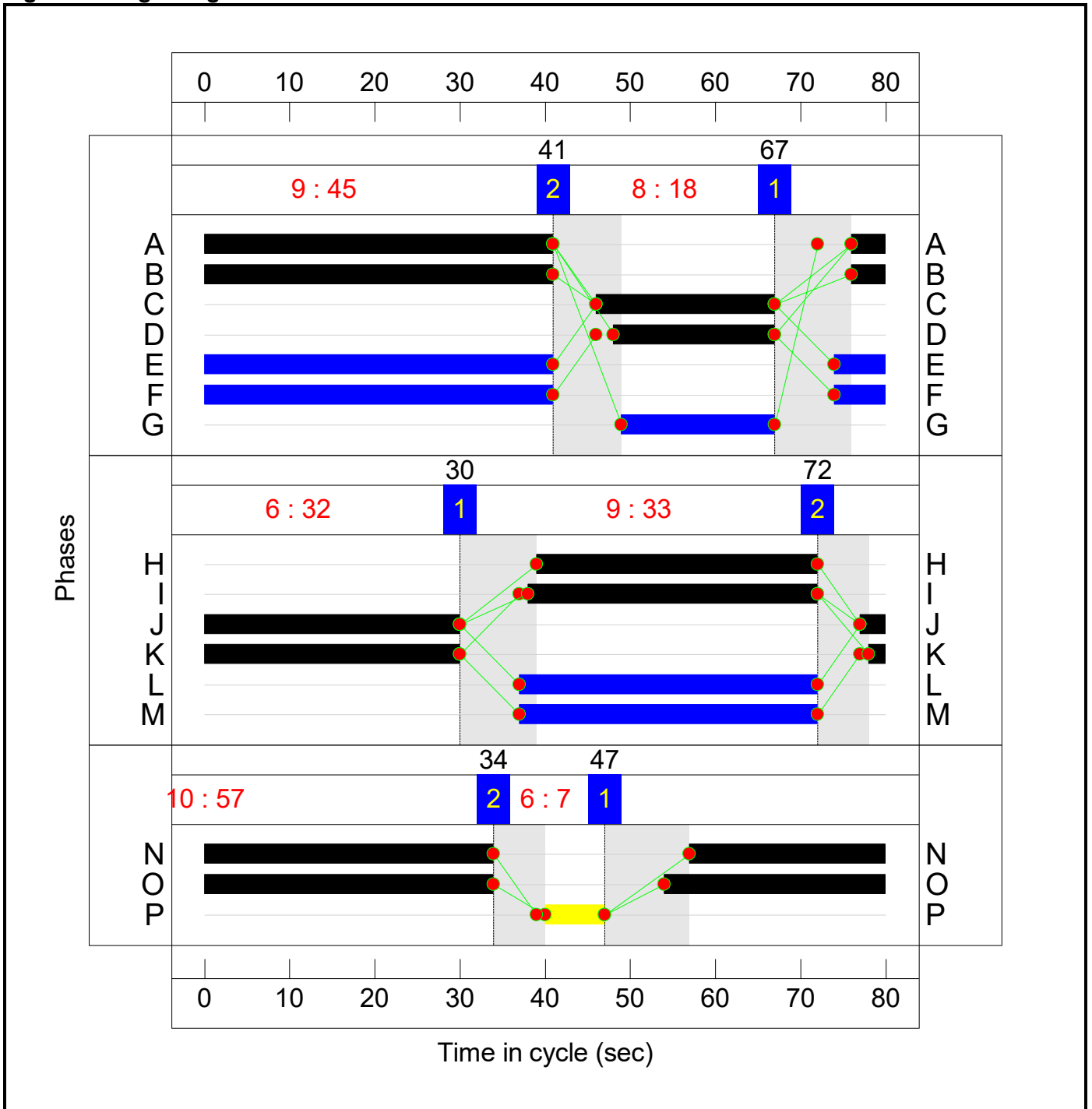

## C2 - Westside Controller Stage Sequence Diagram Stage Stream: 1

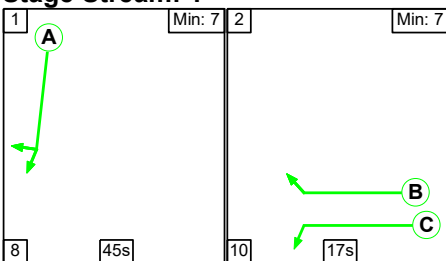

### Stage Stream: 2

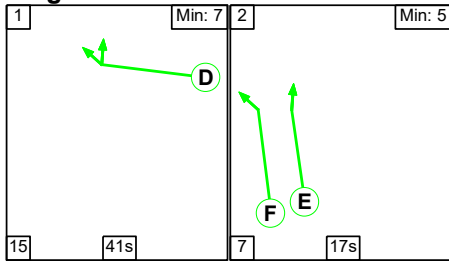

### Stage Stream: 3

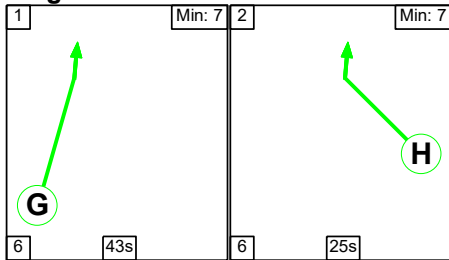

### Stage Stream: 4

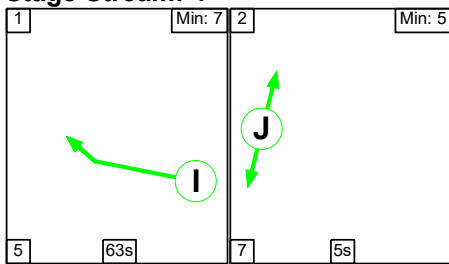

### Stage Timings

#### Stage Stream: 1

Stage	1	2
Duration	45	17
Change Point	24	77

#### Stage Stream: 2

Stage	1	2
Duration	41	17
Change Point	6	62

#### Stage Stream: 3

Stage	1	2
Duration	43	25
Change Point	35	4

#### Stage Stream: 4

Stage	1	2
Duration	63	5
Change Point	16	4

# Signal Timings Diagram

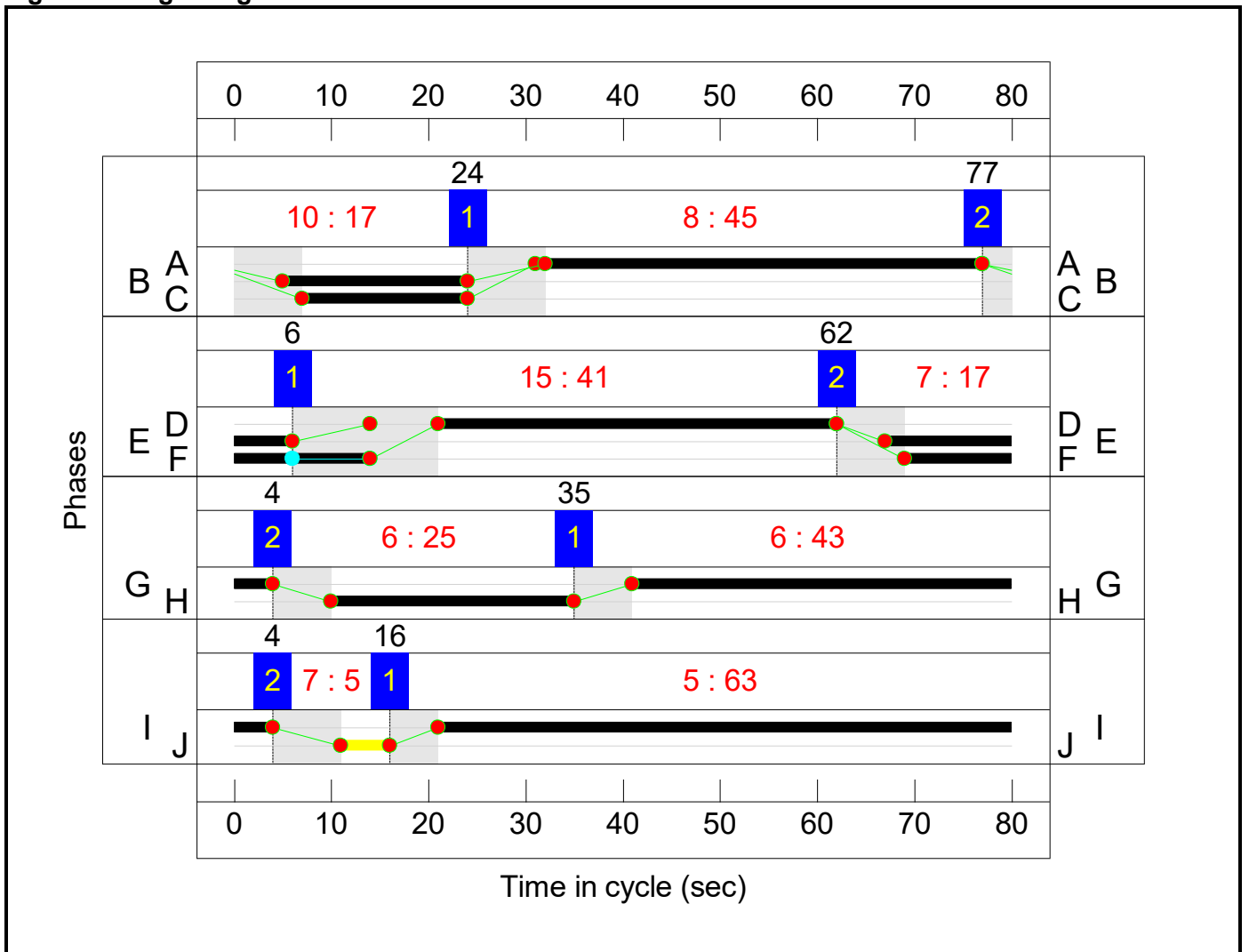

## Network Results

Item	Lane Description	Lane Type	Controller Stream	Position In Filtered Route	Full Phase	Arrow Phase	Num Greens	Total Green (s)	Arrow Green (s)	Demand Flow (pcu)	Sat Flow (pcu/Hr)	Capacity (pcu)	Deg Sat (%)
<b>Network: M1 Junction 15 impact with additional mezzanine</b>	-	-	<b>N/A</b>	-	-		-	-	-	-	-	-	<b>110.6%</b>
<b>M1 Junction 15</b>	-	-	<b>N/A</b>	-	-		-	-	-	-	-	-	<b>110.6%</b>
1/2+1/1	M1 Southbound Offslip Left	U	1:1	N/A	C1:D		1	19	-	785	2120:1980	530+495	76.6 : 76.6%
1/3+1/4	M1 Southbound Offslip Left Ahead	U	1:1	N/A	C1:D C1:C		1	19:21	-	1371	2120:4000	530+1100	84.0 : 84.2%
3/1	Ahead Right	U	1:2	N/A	C1:I		1	34	-	296	1900	831	35.0%
3/2	Right	U	1:2	N/A	C1:I		1	34	-	104	1900	831	12.5%
3/3	Right	U	1:2	N/A	C1:H		1	33	-	319	1900	808	39.5%
3/4	Right	U	1:2	N/A	C1:H		1	33	-	522	1900	808	64.6%
4/2+4/1	A45 Southbound Left Ahead	U	1:2	N/A	C1:K		1	32	-	991	2120:1980	875+817	56.9 : 60.4%
4/3	A45 Southbound Ahead	U	1:2	N/A	C1:J		1	33	-	956	2120	901	106.1%
4/4+4/5	A45 Southbound Ahead	U	1:2	N/A	C1:J		1	33	-	1935	2120:2120	901+901	107.4 : 107.3%
6/1	M1 Northbound Circulatory Ahead	U	2:1	N/A	C2:A		1	45	-	1275	2120	1219	100.1%
6/2+6/3	M1 Northbound Circulatory Ahead Right	U	2:1	N/A	C2:A		1	45	-	1533	2120:2120	720+809	98.5 : 93.6%
6/4	M1 Northbound Circulatory Right	U	2:1	N/A	C2:A		1	45	-	1049	2120	1219	80.6%
8/1	Saxon Avenue Left Left2	U	1:3	N/A	C1:P		1	7	-	63	1934	193	32.6%
8/2	Saxon Avenue Left	U	1:3	N/A	C1:P		1	7	-	82	2105	210	39.0%
9/2+9/1	M1 Northbound Offslip Left Ahead	U	2:1	N/A	C2:B C2:C		1	19:17	-	941	2120:1980	530+330	110.2 : 108.2%

9/3+9/4	M1 Northbound Offslip Ahead	U	2:1	N/A	C2:B		1	19	-	1172	2120:2120	530+530	110.6 : 110.6%
11/1	Ahead	U	2:2	N/A	C2:D		1	41	-	913	1900	997	85.4%
11/2	Ahead Right	U	2:2	N/A	C2:D		1	41	-	947	1900	997	89.0%
12/1	Toucan Crossing Ahead	U	2:4	N/A	C2:I		1	63	-	1242	1995	1596	74.0%
12/2	Toucan Crossing Ahead	U	2:4	N/A	C2:I		1	63	-	1200	1995	1596	71.6%
13/2+13/1	A508 Northampton Rd Ahead	U	2:2	N/A	C2:F		1	25	-	658	1980:1980	549+549	59.9 : 59.9%
13/3	A508 Northampton Rd Ahead	U	2:2	N/A	C2:E		1	19	-	311	2120	530	58.7%
13/4+13/5	A508 Northampton Rd Ahead	U	2:2	N/A	C2:E		1	19	-	683	2120:2120	530+530	63.8 : 65.1%
15/1	Ahead	U	1:1	N/A	C1:A		1	45	-	930	2000	1150	76.0%
15/2	Ahead	U	1:1	N/A	C1:A		1	45	-	924	2000	1150	75.5%
15/3+15/4	Ahead Right	U	1:1	N/A	C1:A C1:B		1	45	-	972	2000:2000	936+449	64.7 : 69.1%
16/1	Right	U	2:3	N/A	C2:H		1	25	-	584	2000	650	81.5%
16/2	Right	U	2:3	N/A	C2:H		1	25	-	586	2000	650	81.5%
16/3	Right	U	2:3	N/A	C2:H		1	25	-	586	2000	650	81.5%
17/1	Ahead	U	2:3	N/A	C2:G		1	43	-	346	2000	1100	31.2%
17/2	Ahead	U	2:3	N/A	C2:G		1	43	-	338	2000	1100	30.7%
17/3	Ahead	U	2:3	N/A	C2:G		1	43	-	386	2000	1100	35.1%
18/1	Ahead	U	1:3	N/A	C1:O		1	60	-	565	2000	1525	37.0%
18/2	Ahead	U	1:3	N/A	C1:O		1	60	-	602	2000	1525	39.5%
19/1	Ahead	U	1:3	N/A	C1:N		1	57	-	1275	2000	1450	84.1%
19/2	Ahead	U	1:3	N/A	C1:N		1	57	-	1490	2120	1537	92.6%
19/3	Ahead	U	1:3	N/A	C1:N		1	57	-	967	2120	1537	58.6%

Item	Arriving (pcu)	Leaving (pcu)	Turners In Gaps (pcu)	Turners When Unopposed (pcu)	Turners In Intergreen (pcu)	Uniform Delay (pcuHr)	Rand + Oversat Delay (pcuHr)	Storage Area Uniform Delay (pcuHr)	Total Delay (pcuHr)	Av. Delay Per PCU (s/pcu)	Max. Back of Uniform Queue (pcu)	Rand + Oversat Queue (pcu)	Mean Max Queue (pcu)
<b>Network: M1 Junction 15 impact with additional mezzanine</b>	-	-	0	0	0	116.7	222.4	0.0	339.1	-	-	-	-
<b>M1 Junction 15</b>	-	-	0	0	0	116.7	222.4	0.0	339.1	-	-	-	-
1/2+1/1	785	785	-	-	-	6.1	1.6	-	7.7 (4.0+3.7)	35.2 (35.2:35.2)	8.3	1.6	10.0
1/3+1/4	1371	1371	-	-	-	10.6	2.6	-	13.2 (4.4+8.8)	34.5 (35.3:34.2)	9.6	2.6	12.2
3/1	291	291	-	-	-	1.2	0.0	-	1.2	14.6	3.9	0.0	3.9
3/2	104	104	-	-	-	0.8	0.0	-	0.8	28.9	2.3	0.0	2.3
3/3	319	319	-	-	-	0.2	0.0	-	0.2	2.8	0.7	0.0	0.7
3/4	522	522	-	-	-	0.2	0.0	-	0.2	1.6	6.2	0.0	6.2
4/2+4/1	991	991	-	-	-	5.0	0.7	-	5.7 (2.9+2.9)	20.8 (20.6:21.0)	8.5	0.7	9.2
4/3	956	901	-	-	-	8.3	34.4	-	42.8	161.0	22.5	34.4	56.9
4/4+4/5	1935	1802	-	-	-	17.7	73.1	-	90.8 (45.7+45.1)	169.0 (169.9:168.0)	23.0	73.1	96.1
6/1	1220	1219	-	-	-	6.8	0.5	-	7.3	21.5	22.2	0.5	22.7
6/2+6/3	1466	1466	-	-	-	7.2	0.0	-	7.2 (3.6+3.6)	17.7 (18.4:17.0)	19.5	0.0	19.5
6/4	983	983	-	-	-	4.9	0.0	-	4.9	18.1	21.8	0.0	21.8
8/1	63	63	-	-	-	0.6	0.2	-	0.8	47.3	1.3	0.2	1.5
8/2	82	82	-	-	-	0.8	0.3	-	1.1	47.7	1.7	0.3	2.0
9/2+9/1	941	887	-	-	-	9.9	45.7	-	55.6 (37.2+18.4)	212.7 (229.4:185.4)	14.2	45.7	59.9
9/3+9/4	1172	1060	-	-	-	14.2	60.8	-	75.0 (37.5+37.5)	230.5 (230.5:230.5)	14.3	60.8	75.1
11/1	852	852	-	-	-	3.0	0.0	-	3.0	12.8	5.7	0.0	5.7
11/2	888	888	-	-	-	3.1	0.0	-	3.1	12.7	6.5	0.0	6.5
12/1	1181	1181	-	-	-	0.2	0.0	-	0.2	0.5	1.1	0.0	1.1

12/2	1143	1143	-	-	-	0.2	0.0	-	0.2	0.5	1.1	0.0	1.1																																																								
13/2+13/1	658	658	-	-	-	4.0	0.7	-	4.7 (2.4+2.4)	25.9 (25.9:25.9)	5.8	0.7	6.6																																																								
13/3	311	311	-	-	-	2.3	0.7	-	3.0	34.5	6.0	0.7	6.8																																																								
13/4+13/5	683	683	-	-	-	5.1	0.9	-	6.0 (3.0+3.0)	31.6 (31.5:31.6)	6.8	0.9	7.7																																																								
15/1	874	874	-	-	-	0.3	0.0	-	0.3	1.4	1.3	0.0	1.3																																																								
15/2	868	868	-	-	-	0.2	0.0	-	0.2	0.9	0.7	0.0	0.7																																																								
15/3+15/4	916	916	-	-	-	0.5	0.0	-	0.5 (0.3+0.2)	2.0 (2.0:1.9)	1.1	0.0	1.1																																																								
16/1	530	530	-	-	-	0.1	0.0	-	0.1	0.6	0.7	0.0	0.7																																																								
16/2	530	530	-	-	-	0.1	0.0	-	0.1	0.6	0.7	0.0	0.7																																																								
16/3	530	530	-	-	-	0.1	0.0	-	0.1	0.6	0.7	0.0	0.7																																																								
17/1	344	344	-	-	-	0.3	0.0	-	0.3	3.2	0.8	0.0	0.8																																																								
17/2	338	338	-	-	-	0.3	0.0	-	0.3	3.2	0.7	0.0	0.7																																																								
17/3	386	386	-	-	-	0.4	0.0	-	0.4	3.6	1.6	0.0	1.6																																																								
18/1	565	565	-	-	-	0.3	0.0	-	0.3	2.0	2.4	0.0	2.4																																																								
18/2	602	602	-	-	-	0.4	0.0	-	0.4	2.2	2.4	0.0	2.4																																																								
19/1	1220	1220	-	-	-	1.0	0.0	-	1.0	2.8	5.1	0.0	5.1																																																								
19/2	1423	1423	-	-	-	0.2	0.0	-	0.2	0.5	0.6	0.0	0.6																																																								
19/3	901	901	-	-	-	0.2	0.0	-	0.2	0.6	0.6	0.0	0.6																																																								
<table border="0"> <tbody> <tr> <td>C1 - Eastside Controller</td><td>Stream: 1 PRC for Signalled Lanes (%)</td><td>6.9</td><td>Total Delay for Signalled Lanes (pcuHr):</td><td>21.90</td><td>Cycle Time (s):</td><td>80</td></tr> <tr> <td>C1 - Eastside Controller</td><td>Stream: 2 PRC for Signalled Lanes (%)</td><td>-19.4</td><td>Total Delay for Signalled Lanes (pcuHr):</td><td>141.79</td><td>Cycle Time (s):</td><td>80</td></tr> <tr> <td>C1 - Eastside Controller</td><td>Stream: 3 PRC for Signalled Lanes (%)</td><td>-2.9</td><td>Total Delay for Signalled Lanes (pcuHr):</td><td>3.90</td><td>Cycle Time (s):</td><td>80</td></tr> <tr> <td>C2 - Westside Controller</td><td>Stream: 1 PRC for Signalled Lanes (%)</td><td>-22.9</td><td>Total Delay for Signalled Lanes (pcuHr):</td><td>150.07</td><td>Cycle Time (s):</td><td>80</td></tr> <tr> <td>C2 - Westside Controller</td><td>Stream: 2 PRC for Signalled Lanes (%)</td><td>1.1</td><td>Total Delay for Signalled Lanes (pcuHr):</td><td>19.88</td><td>Cycle Time (s):</td><td>80</td></tr> <tr> <td>C2 - Westside Controller</td><td>Stream: 3 PRC for Signalled Lanes (%)</td><td>10.4</td><td>Total Delay for Signalled Lanes (pcuHr):</td><td>1.26</td><td>Cycle Time (s):</td><td>80</td></tr> <tr> <td>C2 - Westside Controller</td><td>Stream: 4 PRC for Signalled Lanes (%)</td><td>21.6</td><td>Total Delay for Signalled Lanes (pcuHr):</td><td>0.30</td><td>Cycle Time (s):</td><td>80</td></tr> <tr> <td></td><td>PRC Over All Lanes (%)</td><td>-22.9</td><td>Total Delay Over All Lanes(pcuHr):</td><td>339.10</td><td></td><td></td></tr> </tbody> </table>														C1 - Eastside Controller	Stream: 1 PRC for Signalled Lanes (%)	6.9	Total Delay for Signalled Lanes (pcuHr):	21.90	Cycle Time (s):	80	C1 - Eastside Controller	Stream: 2 PRC for Signalled Lanes (%)	-19.4	Total Delay for Signalled Lanes (pcuHr):	141.79	Cycle Time (s):	80	C1 - Eastside Controller	Stream: 3 PRC for Signalled Lanes (%)	-2.9	Total Delay for Signalled Lanes (pcuHr):	3.90	Cycle Time (s):	80	C2 - Westside Controller	Stream: 1 PRC for Signalled Lanes (%)	-22.9	Total Delay for Signalled Lanes (pcuHr):	150.07	Cycle Time (s):	80	C2 - Westside Controller	Stream: 2 PRC for Signalled Lanes (%)	1.1	Total Delay for Signalled Lanes (pcuHr):	19.88	Cycle Time (s):	80	C2 - Westside Controller	Stream: 3 PRC for Signalled Lanes (%)	10.4	Total Delay for Signalled Lanes (pcuHr):	1.26	Cycle Time (s):	80	C2 - Westside Controller	Stream: 4 PRC for Signalled Lanes (%)	21.6	Total Delay for Signalled Lanes (pcuHr):	0.30	Cycle Time (s):	80		PRC Over All Lanes (%)	-22.9	Total Delay Over All Lanes(pcuHr):	339.10		
C1 - Eastside Controller	Stream: 1 PRC for Signalled Lanes (%)	6.9	Total Delay for Signalled Lanes (pcuHr):	21.90	Cycle Time (s):	80																																																															
C1 - Eastside Controller	Stream: 2 PRC for Signalled Lanes (%)	-19.4	Total Delay for Signalled Lanes (pcuHr):	141.79	Cycle Time (s):	80																																																															
C1 - Eastside Controller	Stream: 3 PRC for Signalled Lanes (%)	-2.9	Total Delay for Signalled Lanes (pcuHr):	3.90	Cycle Time (s):	80																																																															
C2 - Westside Controller	Stream: 1 PRC for Signalled Lanes (%)	-22.9	Total Delay for Signalled Lanes (pcuHr):	150.07	Cycle Time (s):	80																																																															
C2 - Westside Controller	Stream: 2 PRC for Signalled Lanes (%)	1.1	Total Delay for Signalled Lanes (pcuHr):	19.88	Cycle Time (s):	80																																																															
C2 - Westside Controller	Stream: 3 PRC for Signalled Lanes (%)	10.4	Total Delay for Signalled Lanes (pcuHr):	1.26	Cycle Time (s):	80																																																															
C2 - Westside Controller	Stream: 4 PRC for Signalled Lanes (%)	21.6	Total Delay for Signalled Lanes (pcuHr):	0.30	Cycle Time (s):	80																																																															
	PRC Over All Lanes (%)	-22.9	Total Delay Over All Lanes(pcuHr):	339.10																																																																	

**Scenario 3: '2031 Background - PM'** (FG2: '2031 background - PM', Plan 1: 'Network Control Plan 1')

**C1 - Eastside Controller**

**Stage Sequence Diagram**

**Stage Stream: 1**

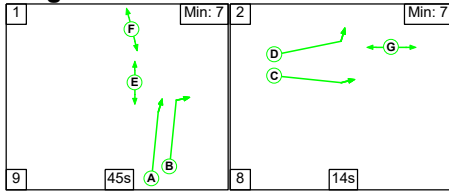

**Stage Stream: 2**

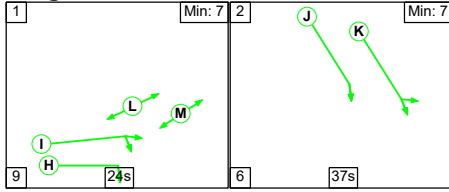

**Stage Stream: 3**

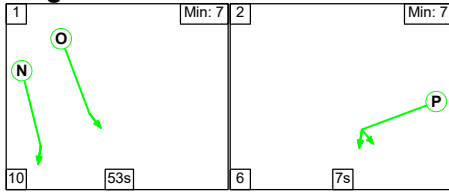

**Stage Timings**

**Stage Stream: 1**

Stage	1	2
Duration	45	14
Change Point	4	58

**Stage Stream: 2**

Stage	1	2
Duration	24	37
Change Point	47	4

**Stage Stream: 3**

Stage	1	2
Duration	53	7
Change Point	58	45

# Signal Timings Diagram

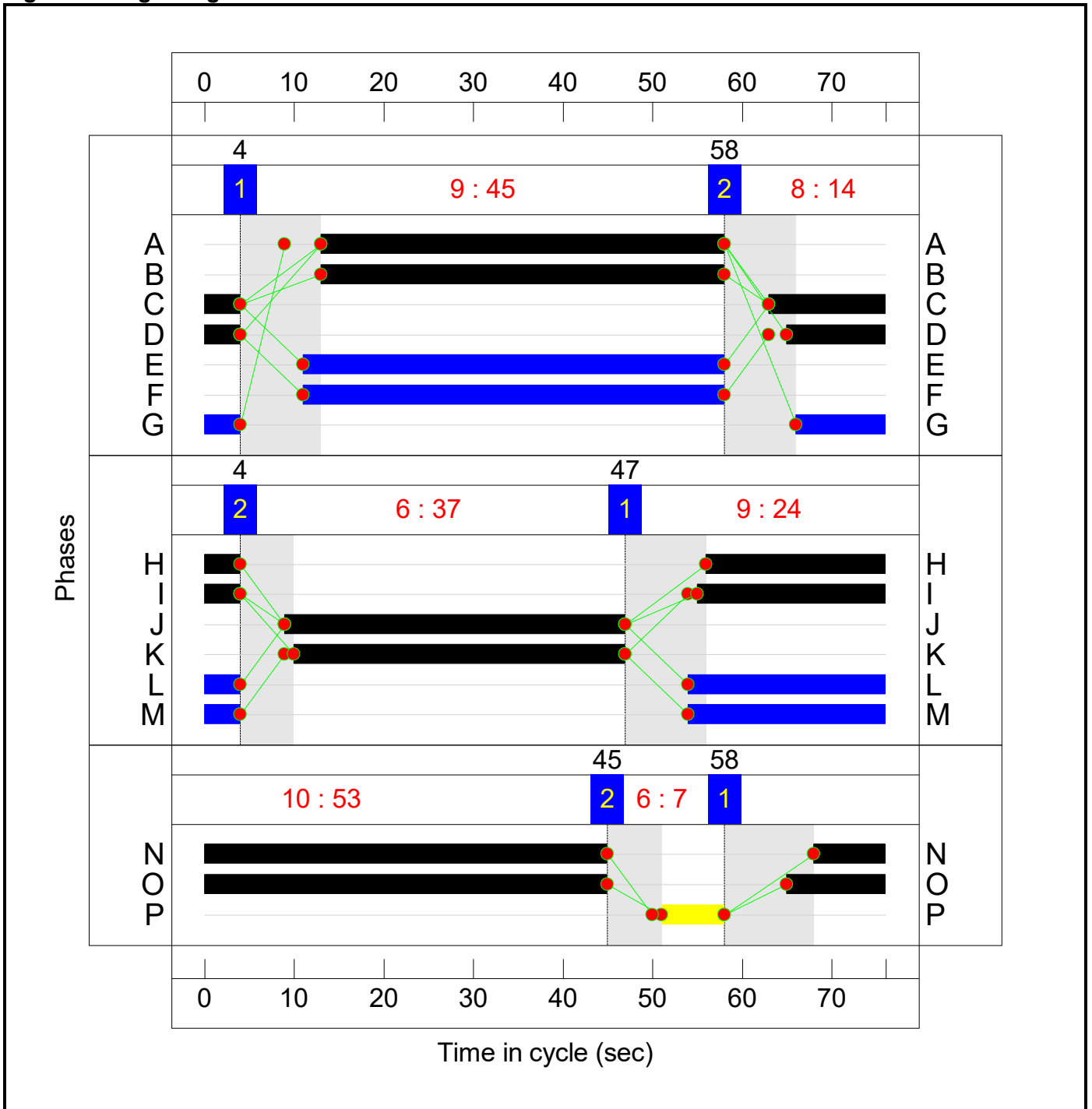

## C2 - Westside Controller Stage Sequence Diagram Stage Stream: 1

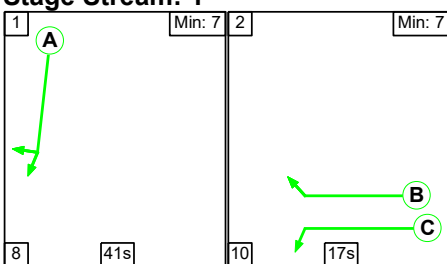

### Stage Stream: 2

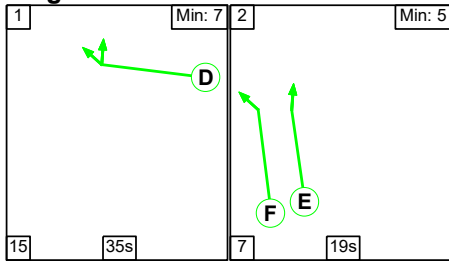

### Stage Stream: 3

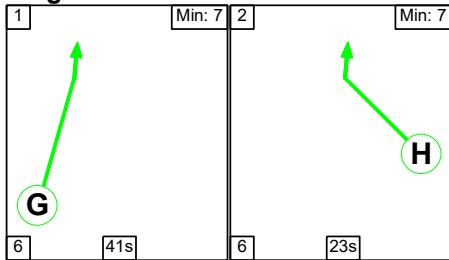

### Stage Stream: 4

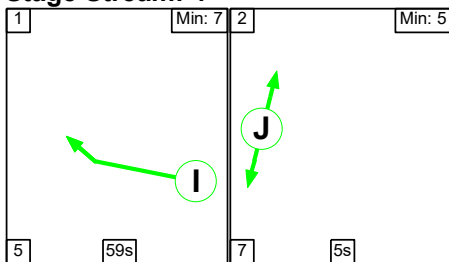

### Stage Timings

#### Stage Stream: 1

Stage	1	2
Duration	41	17
Change Point	24	73

#### Stage Stream: 2

Stage	1	2
Duration	35	19
Change Point	9	59

#### Stage Stream: 3

Stage	1	2
Duration	41	23
Change Point	33	4

#### Stage Stream: 4

Stage	1	2
Duration	59	5
Change Point	18	6

# Signal Timings Diagram

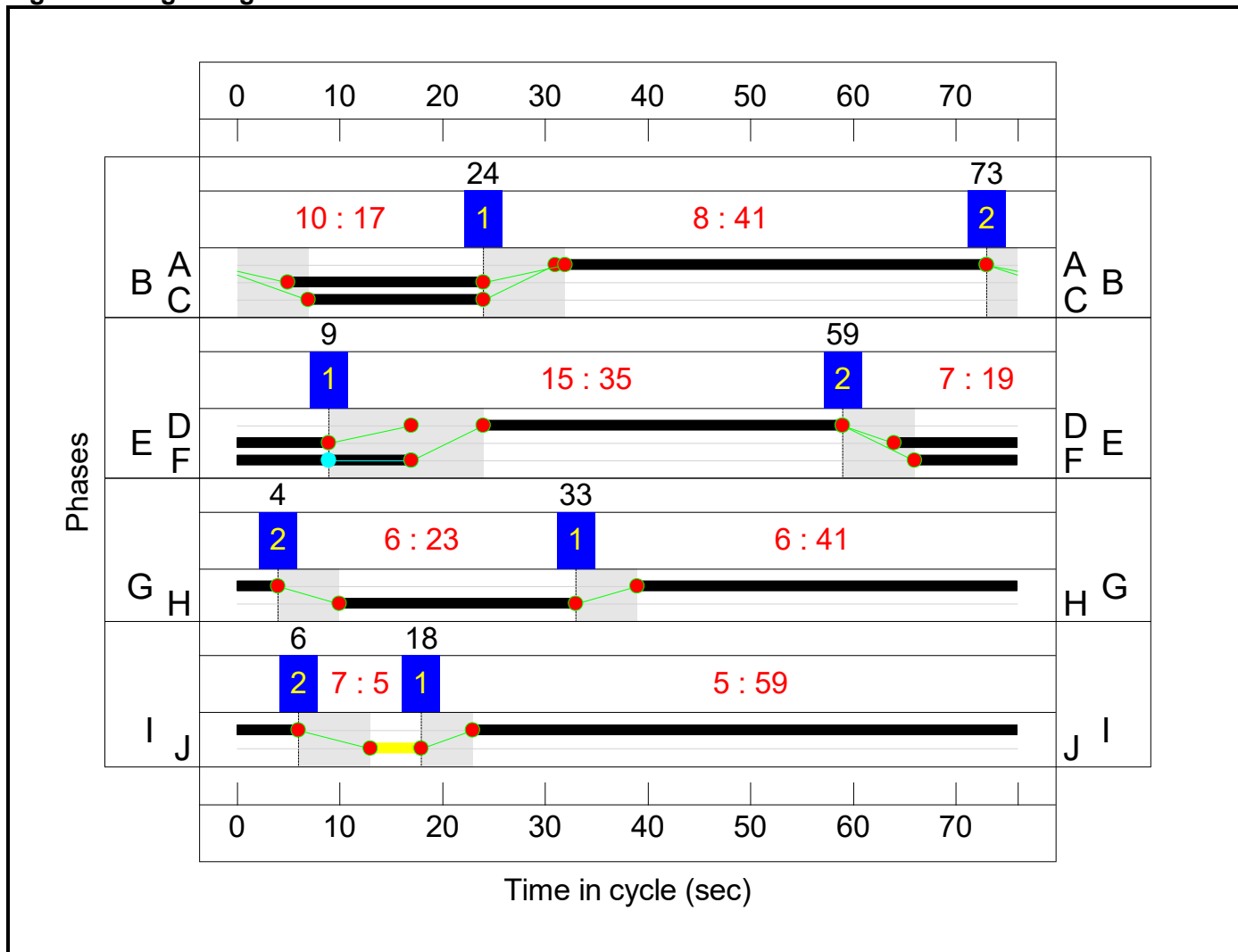

## Network Results

Item	Lane Description	Lane Type	Controller Stream	Position In Filtered Route	Full Phase	Arrow Phase	Num Greens	Total Green (s)	Arrow Green (s)	Demand Flow (pcu)	Sat Flow (pcu/Hr)	Capacity (pcu)	Deg Sat (%)
<b>Network: M1 Junction 15 impact with additional mezzanine</b>	-	-	<b>N/A</b>	-	-		-	-	-	-	-	-	<b>100.4%</b>
<b>M1 Junction 15</b>	-	-	<b>N/A</b>	-	-		-	-	-	-	-	-	<b>100.4%</b>
1/2+1/1	M1 Southbound Offslip Left	U	1:1	N/A	C1:D		1	15	-	604	2120:1980	446+417	69.9 : 70.1%
1/3+1/4	M1 Southbound Offslip Left Ahead	U	1:1	N/A	C1:D C1:C		1	15:17	-	1065	2120:4000	446+947	90.3 : 69.9%
3/1	Ahead Right	U	1:2	N/A	C1:I		1	25	-	246	1900	650	37.8%
3/2	Right	U	1:2	N/A	C1:I		1	25	-	90	1900	650	13.8%
3/3	Right	U	1:2	N/A	C1:H		1	24	-	261	1900	625	41.8%
3/4	Right	U	1:2	N/A	C1:H		1	24	-	352	1900	625	56.3%
4/2+4/1	A45 Southbound Left Ahead	U	1:2	N/A	C1:K		1	37	-	1073	2120:1980	1029+990	52.4 : 53.9%
4/3	A45 Southbound Ahead	U	1:2	N/A	C1:J		1	38	-	865	2120	1088	79.5%
4/4+4/5	A45 Southbound Ahead	U	1:2	N/A	C1:J		1	38	-	1730	2120:2120	836+1088	81.9 : 96.1%
6/1	M1 Northbound Circulatory Ahead	U	2:1	N/A	C2:A		1	41	-	1126	2120	1172	96.1%
6/2+6/3	M1 Northbound Circulatory Ahead Right	U	2:1	N/A	C2:A		1	41	-	1054	2120:2120	901+448	78.2 : 78.2%
6/4	M1 Northbound Circulatory Right	U	2:1	N/A	C2:A		1	41	-	1176	2120	1172	100.4%
8/1	Saxon Avenue Left Left2	U	1:3	N/A	C1:P		1	7	-	139	1883	198	70.1%
8/2	Saxon Avenue Left	U	1:3	N/A	C1:P		1	7	-	130	2105	222	58.7%
9/2+9/1	M1 Northbound Offslip Left Ahead	U	2:1	N/A	C2:B C2:C		1	19:17	-	697	2120:1980	558+232	88.2 : 88.2%

9/3+9/4	M1 Northbound Offslip Ahead	U	2:1	N/A	C2:B		1	19	-	1036	2120:2120	558+558	85.5 : 100.2%
11/1	Ahead	U	2:2	N/A	C2:D		1	35	-	687	1900	900	76.1%
11/2	Ahead Right	U	2:2	N/A	C2:D		1	35	-	839	1900	900	93.0%
12/1	Toucan Crossing Ahead	U	2:4	N/A	C2:I		1	59	-	1041	1995	1575	65.9%
12/2	Toucan Crossing Ahead	U	2:4	N/A	C2:I		1	59	-	1047	1995	1575	66.4%
13/2+13/1	A508 Northampton Rd Ahead	U	2:2	N/A	C2:F		1	27	-	709	1980:1980	604+602	58.8 : 58.8%
13/3	A508 Northampton Rd Ahead	U	2:2	N/A	C2:E		1	21	-	540	2120	614	88.0%
13/4+13/5	A508 Northampton Rd Ahead	U	2:2	N/A	C2:E		1	21	-	1162	2120:2120	614+614	91.9 : 97.4%
15/1	Ahead	U	1:1	N/A	C1:A		1	45	-	1151	2000	1211	95.1%
15/2	Ahead	U	1:1	N/A	C1:A		1	45	-	1067	2000	1211	88.1%
15/3+15/4	Ahead Right	U	1:1	N/A	C1:A C1:B		1	45	-	1159	2000:2000	1040+342	83.7 : 83.8%
16/1	Right	U	2:3	N/A	C2:H		1	23	-	492	2000	632	77.9%
16/2	Right	U	2:3	N/A	C2:H		1	23	-	477	2000	632	75.5%
16/3	Right	U	2:3	N/A	C2:H		1	23	-	559	2000	632	88.3%
17/1	Ahead	U	2:3	N/A	C2:G		1	41	-	659	2000	1105	59.6%
17/2	Ahead	U	2:3	N/A	C2:G		1	41	-	590	2000	1105	53.3%
17/3	Ahead	U	2:3	N/A	C2:G		1	41	-	600	2000	1105	54.3%
18/1	Ahead	U	1:3	N/A	C1:O		1	56	-	555	2000	1500	37.0%
18/2	Ahead	U	1:3	N/A	C1:O		1	56	-	629	2000	1500	41.9%
19/1	Ahead	U	1:3	N/A	C1:N		1	53	-	1126	2000	1421	79.2%
19/2	Ahead	U	1:3	N/A	C1:N		1	53	-	1036	2120	1506	68.8%
19/3	Ahead	U	1:3	N/A	C1:N		1	53	-	1046	2120	1506	69.4%

Item	Arriving (pcu)	Leaving (pcu)	Turners In Gaps (pcu)	Turners When Unopposed (pcu)	Turners In Intergreen (pcu)	Uniform Delay (pcuHr)	Rand + Oversat Delay (pcuHr)	Storage Area Uniform Delay (pcuHr)	Total Delay (pcuHr)	Av. Delay Per PCU (s/pcu)	Max. Back of Uniform Queue (pcu)	Rand + Oversat Queue (pcu)	Mean Max Queue (pcu)
<b>Network: M1 Junction 15 impact with additional mezzanine</b>	-	-	0	0	0	103.8	34.6	0.0	138.4	-	-	-	-
<b>M1 Junction 15</b>	-	-	0	0	0	103.8	34.6	0.0	138.4	-	-	-	-
1/2+1/1	604	604	-	-	-	4.7	1.2	-	5.8 (3.0+2.8)	34.7 (34.7:34.7)	6.1	1.2	7.2
1/3+1/4	1065	1065	-	-	-	8.2	1.6	-	9.8 (3.9+5.9)	33.0 (34.7:32.0)	8.3	1.6	9.9
3/1	246	246	-	-	-	0.9	0.0	-	0.9	13.6	2.8	0.0	2.8
3/2	90	90	-	-	-	0.5	0.0	-	0.5	19.1	1.3	0.0	1.3
3/3	261	261	-	-	-	0.5	0.0	-	0.5	6.4	1.1	0.0	1.1
3/4	352	352	-	-	-	0.4	0.0	-	0.4	4.4	0.7	0.0	0.7
4/2+4/1	1073	1073	-	-	-	3.8	0.6	-	4.4 (2.2+2.2)	14.8 (14.6:14.9)	7.7	0.6	8.3
4/3	865	865	-	-	-	3.7	1.9	-	5.6	23.2	14.9	1.9	16.8
4/4+4/5	1730	1730	-	-	-	7.7	4.3	-	12.0 (4.2+7.8)	24.9 (22.2:26.7)	21.2	4.3	25.5
6/1	1126	1126	-	-	-	6.6	0.0	-	6.6	21.0	23.8	0.0	23.8
6/2+6/3	1054	1054	-	-	-	6.4	0.0	-	6.4 (4.4+2.0)	21.9 (22.3:20.9)	21.6	0.0	21.6
6/4	1176	1172	-	-	-	4.8	2.2	-	7.0	21.4	25.0	2.2	27.2
8/1	139	139	-	-	-	1.3	1.1	-	2.4	62.1	2.8	1.1	3.9
8/2	130	130	-	-	-	1.2	0.7	-	1.9	51.8	2.6	0.7	3.3
9/2+9/1	697	697	-	-	-	5.1	3.5	-	8.6 (6.1+2.4)	44.2 (44.8:42.6)	9.8	3.5	13.3
9/3+9/4	1036	1035	-	-	-	7.9	6.2	-	14.2 (6.1+8.0)	49.2 (46.4:51.6)	11.8	6.2	18.1
11/1	684	684	-	-	-	4.1	0.0	-	4.1	21.6	8.9	0.0	8.9
11/2	837	837	-	-	-	4.1	0.0	-	4.1	17.5	8.9	0.0	8.9
12/1	1038	1038	-	-	-	0.2	0.0	-	0.2	0.6	1.3	0.0	1.3

12/2	1046	1046	-	-	-	0.2	0.0	-	0.2	0.6	1.3	0.0	1.3
13/2+13/1	709	709	-	-	-	3.6	0.7	-	4.3 (2.2+2.2)	22.1 (22.1:22.1)	5.7	0.7	6.4
13/3	540	540	-	-	-	3.9	3.4	-	7.2	48.1	10.8	3.4	14.2
13/4+13/5	1162	1162	-	-	-	8.5	7.3	-	15.8 (7.6+8.2)	49.0 (48.7:49.2)	12.5	7.3	19.7
15/1	1151	1151	-	-	-	2.6	0.0	-	2.6	8.1	18.2	0.0	18.2
15/2	1066	1066	-	-	-	1.8	0.0	-	1.8	5.9	16.7	0.0	16.7
15/3+15/4	1158	1158	-	-	-	0.7	0.0	-	0.7 (0.5+0.3)	2.3 (1.9:3.7)	12.2	0.0	12.2
16/1	492	492	-	-	-	0.1	0.0	-	0.1	0.5	0.5	0.0	0.5
16/2	477	477	-	-	-	0.1	0.0	-	0.1	0.5	0.5	0.0	0.5
16/3	558	558	-	-	-	0.1	0.0	-	0.1	0.6	0.7	0.0	0.7
17/1	659	659	-	-	-	2.4	0.0	-	2.4	13.1	6.3	0.0	6.3
17/2	589	589	-	-	-	2.5	0.0	-	2.5	15.1	5.8	0.0	5.8
17/3	600	600	-	-	-	2.8	0.0	-	2.8	16.7	6.0	0.0	6.0
18/1	555	555	-	-	-	0.3	0.0	-	0.3	2.0	3.2	0.0	3.2
18/2	629	629	-	-	-	0.4	0.0	-	0.4	2.3	2.9	0.0	2.9
19/1	1126	1126	-	-	-	0.8	0.0	-	0.8	2.4	3.0	0.0	3.0
19/2	1036	1036	-	-	-	0.4	0.0	-	0.4	1.4	1.9	0.0	1.9
19/3	1046	1046	-	-	-	0.9	0.0	-	0.9	3.2	3.2	0.0	3.2

C1 - Eastside Controller	Stream: 1 PRC for Signalled Lanes (%)	-5.6	Total Delay for Signalled Lanes (pcuHr):	20.68	Cycle Time (s):	76
C1 - Eastside Controller	Stream: 2 PRC for Signalled Lanes (%)	-6.8	Total Delay for Signalled Lanes (pcuHr):	24.24	Cycle Time (s):	76
C1 - Eastside Controller	Stream: 3 PRC for Signalled Lanes (%)	13.6	Total Delay for Signalled Lanes (pcuHr):	7.07	Cycle Time (s):	76
C2 - Westside Controller	Stream: 1 PRC for Signalled Lanes (%)	-11.5	Total Delay for Signalled Lanes (pcuHr):	42.66	Cycle Time (s):	76
C2 - Westside Controller	Stream: 2 PRC for Signalled Lanes (%)	-8.3	Total Delay for Signalled Lanes (pcuHr):	35.56	Cycle Time (s):	76
C2 - Westside Controller	Stream: 3 PRC for Signalled Lanes (%)	1.9	Total Delay for Signalled Lanes (pcuHr):	7.86	Cycle Time (s):	76
C2 - Westside Controller	Stream: 4 PRC for Signalled Lanes (%)	35.5	Total Delay for Signalled Lanes (pcuHr):	0.36	Cycle Time (s):	76
	PRC Over All Lanes (%)	-11.5	Total Delay Over All Lanes (pcuHr):	138.43		

**Scenario 4: '2031 With additional mez - PM ' (FG4: '2031 with additional mez - PM', Plan 1: 'Network Control Plan 1')**

**C1 - Eastside Controller  
Stage Sequence Diagram**

**Stage Stream: 1**

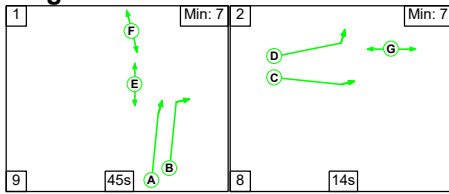

**Stage Stream: 2**

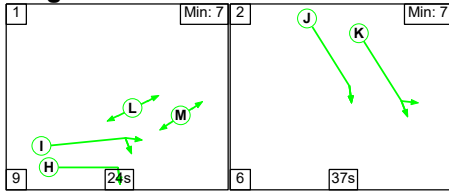

**Stage Stream: 3**

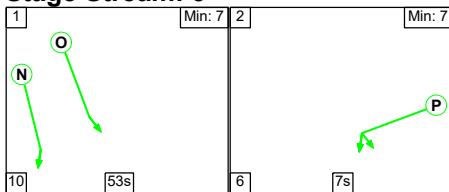

**Stage Timings**

**Stage Stream: 1**

Stage	1	2
Duration	45	14
Change Point	4	58

**Stage Stream: 2**

Stage	1	2
Duration	24	37
Change Point	47	4

**Stage Stream: 3**

Stage	1	2
Duration	53	7
Change Point	58	45

# Signal Timings Diagram

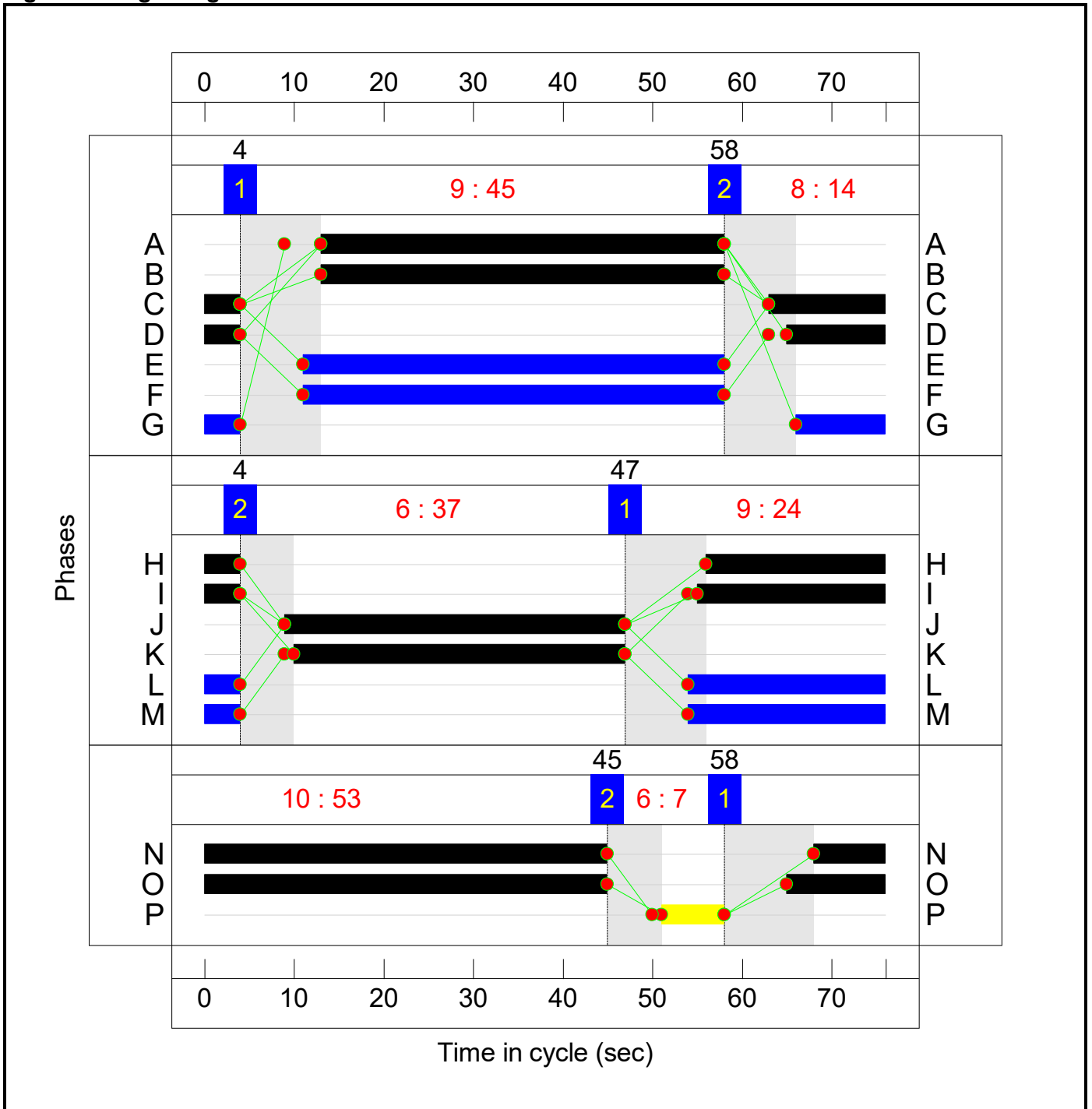

## C2 - Westside Controller Stage Sequence Diagram Stage Stream: 1

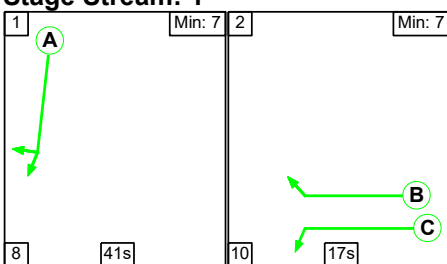

### Stage Stream: 2

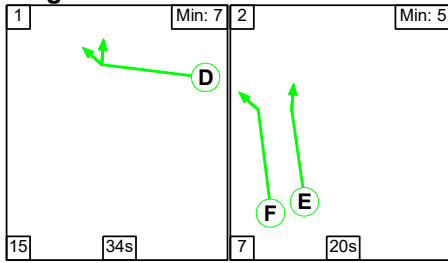

### Stage Stream: 3

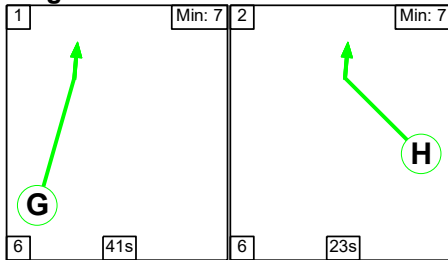

### Stage Stream: 4

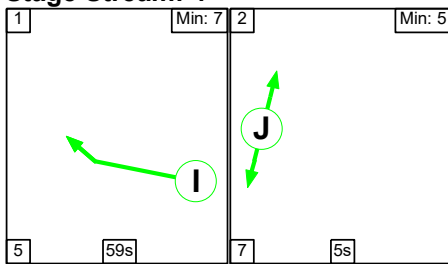

### Stage Timings

#### Stage Stream: 1

Stage	1	2
Duration	41	17
Change Point	24	73

#### Stage Stream: 2

Stage	1	2
Duration	34	20
Change Point	10	59

#### Stage Stream: 3

Stage	1	2
Duration	41	23
Change Point	33	4

#### Stage Stream: 4

Stage	1	2
Duration	59	5
Change Point	19	7

# Signal Timings Diagram

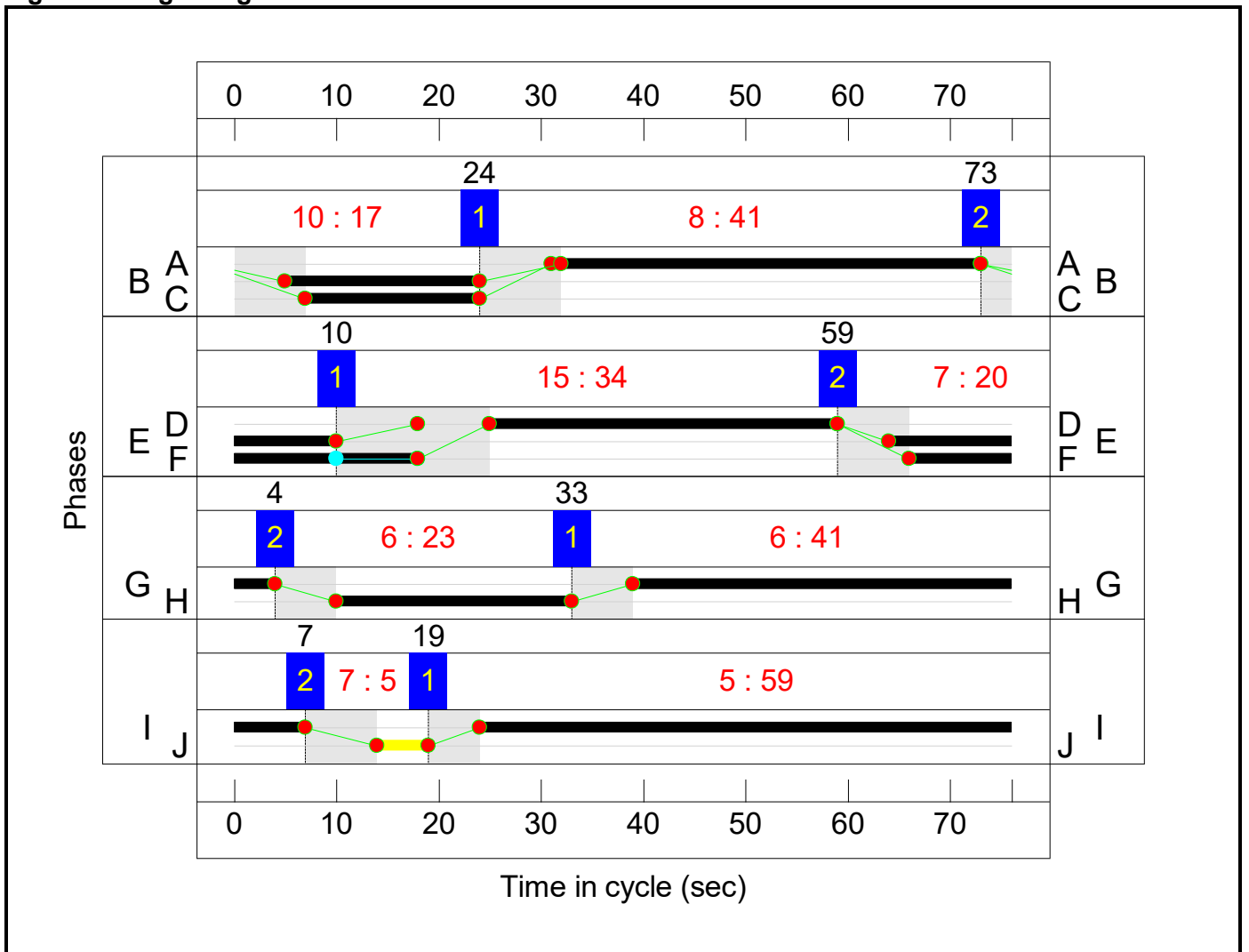

## Network Results

Item	Lane Description	Lane Type	Controller Stream	Position In Filtered Route	Full Phase	Arrow Phase	Num Greens	Total Green (s)	Arrow Green (s)	Demand Flow (pcu)	Sat Flow (pcu/Hr)	Capacity (pcu)	Deg Sat (%)
<b>Network: M1 Junction 15 impact with additional mezzanine</b>	-	-	<b>N/A</b>	-	-		-	-	-	-	-	-	<b>100.5%</b>
<b>M1 Junction 15</b>	-	-	<b>N/A</b>	-	-		-	-	-	-	-	-	<b>100.5%</b>
1/2+1/1	M1 Southbound Offslip Left	U	1:1	N/A	C1:D		1	15	-	607	2120:1980	446+417	70.4 : 70.3%
1/3+1/4	M1 Southbound Offslip Left Ahead	U	1:1	N/A	C1:D C1:C		1	15:17	-	1076	2120:4000	446+947	89.6 : 71.4%
3/1	Ahead Right	U	1:2	N/A	C1:I		1	25	-	257	1900	650	39.5%
3/2	Right	U	1:2	N/A	C1:I		1	25	-	102	1900	650	15.7%
3/3	Right	U	1:2	N/A	C1:H		1	24	-	274	1900	625	43.8%
3/4	Right	U	1:2	N/A	C1:H		1	24	-	353	1900	625	56.5%
4/2+4/1	A45 Southbound Left Ahead	U	1:2	N/A	C1:K		1	37	-	1073	2120:1980	1029+990	52.4 : 53.9%
4/3	A45 Southbound Ahead	U	1:2	N/A	C1:J		1	38	-	866	2120	1088	79.6%
4/4+4/5	A45 Southbound Ahead	U	1:2	N/A	C1:J		1	38	-	1749	2120:2120	851+1088	82.5 : 96.2%
6/1	M1 Northbound Circulatory Ahead	U	2:1	N/A	C2:A		1	41	-	1140	2120	1172	97.3%
6/2+6/3	M1 Northbound Circulatory Ahead Right	U	2:1	N/A	C2:A		1	41	-	1073	2120:2120	906+437	79.9 : 79.9%
6/4	M1 Northbound Circulatory Right	U	2:1	N/A	C2:A		1	41	-	1177	2120	1172	100.5%
8/1	Saxon Avenue Left Left2	U	1:3	N/A	C1:P		1	7	-	139	1883	198	70.1%
8/2	Saxon Avenue Left	U	1:3	N/A	C1:P		1	7	-	130	2105	222	58.7%
9/2+9/1	M1 Northbound Offslip Left Ahead	U	2:1	N/A	C2:B C2:C		1	19:17	-	707	2120:1980	558+244	88.2 : 88.2%

9/3+9/4	M1 Northbound Offslip Ahead	U	2:1	N/A	C2:B		1	19	-	1036	2120:2120	558+558	85.9 : 99.8%
11/1	Ahead	U	2:2	N/A	C2:D		1	34	-	687	1900	875	78.2%
11/2	Ahead Right	U	2:2	N/A	C2:D		1	34	-	839	1900	875	95.6%
12/1	Toucan Crossing Ahead	U	2:4	N/A	C2:I		1	59	-	1052	1995	1575	66.6%
12/2	Toucan Crossing Ahead	U	2:4	N/A	C2:I		1	59	-	1056	1995	1575	66.9%
13/2+13/1	A508 Northampton Rd Ahead	U	2:2	N/A	C2:F		1	28	-	729	1980:1980	615+617	59.1 : 59.1%
13/3	A508 Northampton Rd Ahead	U	2:2	N/A	C2:E		1	22	-	574	2120	642	89.5%
13/4+13/5	A508 Northampton Rd Ahead	U	2:2	N/A	C2:E		1	22	-	1202	2120:2120	642+642	91.6 : 95.7%
15/1	Ahead	U	1:1	N/A	C1:A		1	45	-	1183	2000	1211	97.7%
15/2	Ahead	U	1:1	N/A	C1:A		1	45	-	1097	2000	1211	90.5%
15/3+15/4	Ahead Right	U	1:1	N/A	C1:A C1:B		1	45	-	1171	2000:2000	1028+370	83.8 : 83.8%
16/1	Right	U	2:3	N/A	C2:H		1	23	-	492	2000	632	77.9%
16/2	Right	U	2:3	N/A	C2:H		1	23	-	479	2000	632	75.8%
16/3	Right	U	2:3	N/A	C2:H		1	23	-	557	2000	632	88.2%
17/1	Ahead	U	2:3	N/A	C2:G		1	41	-	691	2000	1105	62.5%
17/2	Ahead	U	2:3	N/A	C2:G		1	41	-	618	2000	1105	55.8%
17/3	Ahead	U	2:3	N/A	C2:G		1	41	-	614	2000	1105	55.6%
18/1	Ahead	U	1:3	N/A	C1:O		1	56	-	566	2000	1500	37.7%
18/2	Ahead	U	1:3	N/A	C1:O		1	56	-	641	2000	1500	42.7%
19/1	Ahead	U	1:3	N/A	C1:N		1	53	-	1140	2000	1421	80.2%
19/2	Ahead	U	1:3	N/A	C1:N		1	53	-	1055	2120	1506	70.0%
19/3	Ahead	U	1:3	N/A	C1:N		1	53	-	1047	2120	1506	69.5%

Item	Arriving (pcu)	Leaving (pcu)	Turners In Gaps (pcu)	Turners When Unopposed (pcu)	Turners In Intergreen (pcu)	Uniform Delay (pcuHr)	Rand + Oversat Delay (pcuHr)	Storage Area Uniform Delay (pcuHr)	Total Delay (pcuHr)	Av. Delay Per PCU (s/pcu)	Max. Back of Uniform Queue (pcu)	Rand + Oversat Queue (pcu)	Mean Max Queue (pcu)
<b>Network: M1 Junction 15 impact with additional mezzanine</b>	-	-	0	0	0	106.8	34.4	0.0	141.2	-	-	-	-
<b>M1 Junction 15</b>	-	-	0	0	0	106.8	34.4	0.0	141.2	-	-	-	-
1/2+1/1	607	607	-	-	-	4.7	1.2	-	5.9 (3.0+2.8)	34.8 (34.8:34.8)	6.1	1.2	7.3
1/3+1/4	1076	1076	-	-	-	8.2	1.7	-	9.9 (3.9+6.1)	33.2 (34.8:32.2)	8.1	1.7	9.8
3/1	257	257	-	-	-	1.0	0.0	-	1.0	13.9	3.0	0.0	3.0
3/2	102	102	-	-	-	0.5	0.0	-	0.5	19.1	1.6	0.0	1.6
3/3	274	274	-	-	-	0.5	0.0	-	0.5	6.2	1.1	0.0	1.1
3/4	353	353	-	-	-	0.4	0.0	-	0.4	4.5	0.6	0.0	0.6
4/2+4/1	1073	1073	-	-	-	3.8	0.6	-	4.4 (2.2+2.2)	14.8 (14.6:14.9)	7.7	0.6	8.3
4/3	866	866	-	-	-	3.7	1.9	-	5.6	23.2	14.9	1.9	16.8
4/4+4/5	1749	1749	-	-	-	7.8	4.4	-	12.2 (4.4+7.8)	25.1 (22.5:26.9)	21.2	4.4	25.6
6/1	1140	1140	-	-	-	6.8	0.0	-	6.8	21.4	24.1	0.0	24.1
6/2+6/3	1073	1073	-	-	-	6.6	0.0	-	6.6 (4.5+2.0)	22.0 (22.5:21.1)	22.0	0.0	22.0
6/4	1177	1172	-	-	-	4.8	2.7	-	7.6	23.1	25.1	2.7	27.8
8/1	139	139	-	-	-	1.3	1.1	-	2.4	62.1	2.8	1.1	3.9
8/2	130	130	-	-	-	1.2	0.7	-	1.9	51.8	2.6	0.7	3.3
9/2+9/1	707	707	-	-	-	5.2	3.5	-	8.6 (6.1+2.5)	44.0 (44.6:42.5)	9.8	3.5	13.3
9/3+9/4	1036	1036	-	-	-	7.9	5.7	-	13.6 (6.2+7.4)	47.1 (46.4:47.7)	11.6	5.7	17.3
11/1	684	684	-	-	-	4.2	0.0	-	4.2	22.1	9.4	0.0	9.4
11/2	836	836	-	-	-	4.3	0.0	-	4.3	18.5	12.5	0.0	12.5
12/1	1049	1049	-	-	-	0.2	0.0	-	0.2	0.6	1.3	0.0	1.3

12/2	1054	1054	-	-	-	0.2	0.0	-	0.2	0.6	1.3	0.0	1.3
13/2+13/1	729	729	-	-	-	3.6	0.7	-	4.3 (2.2+2.2)	21.4 (21.4:21.4)	5.8	0.7	6.5
13/3	574	574	-	-	-	4.0	3.8	-	7.9	49.3	11.5	3.8	15.3
13/4+13/5	1202	1202	-	-	-	8.6	6.4	-	15.0 (7.3+7.7)	45.0 (44.7:45.2)	12.6	6.4	19.0
15/1	1183	1183	-	-	-	3.2	0.0	-	3.2	9.6	18.9	0.0	18.9
15/2	1096	1096	-	-	-	2.0	0.0	-	2.0	6.4	17.0	0.0	17.0
15/3+15/4	1171	1171	-	-	-	0.8	0.0	-	0.8 (0.5+0.4)	2.5 (1.9:4.1)	10.6	0.0	10.6
16/1	492	492	-	-	-	0.1	0.0	-	0.1	0.5	0.5	0.0	0.5
16/2	479	479	-	-	-	0.1	0.0	-	0.1	0.5	0.5	0.0	0.5
16/3	557	557	-	-	-	0.1	0.0	-	0.1	0.6	0.6	0.0	0.6
17/1	691	691	-	-	-	2.7	0.0	-	2.7	14.2	6.9	0.0	6.9
17/2	617	617	-	-	-	2.7	0.0	-	2.7	15.8	6.4	0.0	6.4
17/3	614	614	-	-	-	2.9	0.0	-	2.9	17.2	6.3	0.0	6.3
18/1	566	566	-	-	-	0.3	0.0	-	0.3	2.1	3.4	0.0	3.4
18/2	641	641	-	-	-	0.4	0.0	-	0.4	2.3	3.2	0.0	3.2
19/1	1140	1140	-	-	-	0.8	0.0	-	0.8	2.4	3.1	0.0	3.1
19/2	1055	1055	-	-	-	0.4	0.0	-	0.4	1.4	2.0	0.0	2.0
19/3	1047	1047	-	-	-	0.9	0.0	-	0.9	3.2	3.3	0.0	3.3

C1 - Eastside Controller	Stream: 1 PRC for Signalled Lanes (%)	-8.6	Total Delay for Signalled Lanes (pcuHr):	21.71	Cycle Time (s):	76
C1 - Eastside Controller	Stream: 2 PRC for Signalled Lanes (%)	-6.9	Total Delay for Signalled Lanes (pcuHr):	24.63	Cycle Time (s):	76
C1 - Eastside Controller	Stream: 3 PRC for Signalled Lanes (%)	12.2	Total Delay for Signalled Lanes (pcuHr):	7.12	Cycle Time (s):	76
C2 - Westside Controller	Stream: 1 PRC for Signalled Lanes (%)	-11.6	Total Delay for Signalled Lanes (pcuHr):	43.08	Cycle Time (s):	76
C2 - Westside Controller	Stream: 2 PRC for Signalled Lanes (%)	-6.3	Total Delay for Signalled Lanes (pcuHr):	35.71	Cycle Time (s):	76
C2 - Westside Controller	Stream: 3 PRC for Signalled Lanes (%)	2.1	Total Delay for Signalled Lanes (pcuHr):	8.59	Cycle Time (s):	76
C2 - Westside Controller	Stream: 4 PRC for Signalled Lanes (%)	34.4	Total Delay for Signalled Lanes (pcuHr):	0.37	Cycle Time (s):	76
	PRC Over All Lanes (%)	-11.6	Total Delay Over All Lanes (pcuHr):	141.22		



## Phase Diagram

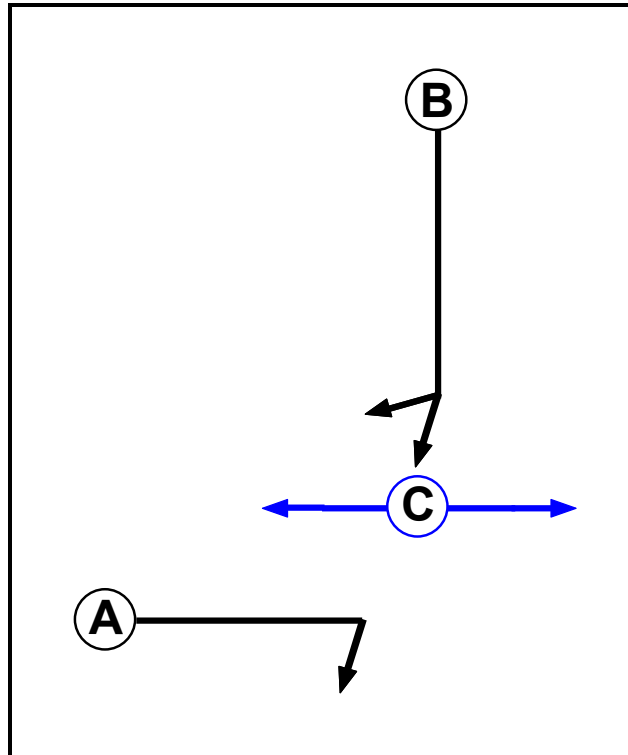

## Phase Input Data

Phase Name	Phase Type	Stage Stream	Assoc. Phase	Street Min	Cont Min
A	Traffic	1		7	4
B	Traffic	1		7	7
C	Pedestrian	1		6	6

## Phase Intergreens Matrix

	Starting Phase		
	A	B	C
Terminating Phase	A	5	-
	B	6	6
	C	-	8

## Phases in Stage

Stream	Stage No.	Phases in Stage
1	1	A C
1	2	B

### Stage Diagram

Stage Stream: 1

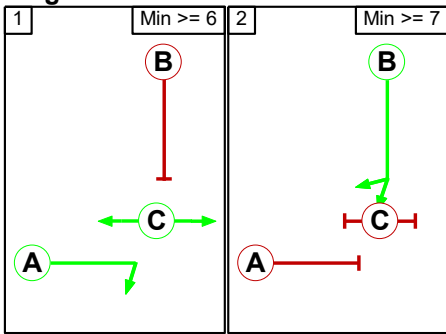

### Phase Delays

Stage Stream: 1

Term. Stage	Start Stage	Phase	Type	Value	Cont value
1	2	A	Losing	3	3

### Prohibited Stage Change

Stage Stream: 1

From Stage	To Stage	
	1	2
1		8
2	6	

### Give-Way Lane Input Data

Junction: A508/Site Access											
Lane	Movement	Max Flow when Giving Way (PCU/Hr)	Min Flow when Giving Way (PCU/Hr)	Opposing Lane	Opp. Lane Coeff.	Opp. Mvmnts.	Right Turn Storage (PCU)	Non-Blocking Storage (PCU)	RTF	Right Turn Move up (s)	Max Turns in Intergreen (PCU)
4/1 (A508 South)	3/1 (Left)	1106	0	8/1	0.25	All	-	-	-	-	-
				8/2	0.25	All					
4/2 (A508 South)	9/1 (Ahead)	1106	0	8/1	0.25	All	-	-	-	-	-
				8/2	0.25	All					
6/2 (Site Access)	7/1 (Ahead)	1000	0	9/1	0.33	All	-	-	-	-	-
				9/2	0.33	All					
6/3 (Site Access)	7/2 (Ahead)	1000	0	9/1	0.33	All	-	-	-	-	-
				9/2	0.33	All					

## Lane Input Data

Junction: A508/Site Access												
Lane	Lane Type	Phases	Start Disp.	End Disp.	Physical Length (PCU)	Sat Flow Type	Def User Saturation Flow (PCU/Hr)	Lane Width (m)	Gradient	Nearside Lane	Turns	Turning Radius (m)
1/1 (A508 North)	U	B	2	3	60.0	Geom	-	3.65	0.00	Y	Arm 2 Ahead	22.00
1/2 (A508 North)	U	B	2	3	60.0	Geom	-	3.65	0.00	N	Arm 2 Ahead	25.00
1/3 (A508 North)	U	B	2	3	6.3	Geom	-	3.65	0.00	N	Arm 8 Right	25.00
2/1	U		2	3	60.0	Inf	-	-	-	-	-	-
2/2	U		2	3	60.0	Inf	-	-	-	-	-	-
3/1	U		2	3	60.0	Inf	-	-	-	-	-	-
3/2	U		2	3	60.0	Inf	-	-	-	-	-	-
4/1 (A508 South)	O		2	3	60.0	Geom	-	3.50	0.00	Y	Arm 3 Left	30.00
											Arm 9 Ahead	Inf
4/2 (A508 South)	O		2	3	10.0	Geom	-	3.50	0.00	N	Arm 9 Ahead	Inf
5/1	U		2	3	60.0	Inf	-	-	-	-	-	-
5/2	U		2	3	60.0	Inf	-	-	-	-	-	-
5/3	U		2	3	60.0	Inf	-	-	-	-	-	-
6/1 (Site Access)	U		2	3	60.0	Geom	-	3.50	0.00	Y	Arm 5 Left	30.00
6/2 (Site Access)	O		2	3	60.0	Inf	-	-	-	-	-	-
6/3 (Site Access)	O		2	3	5.0	Inf	-	-	-	-	-	-
7/1	U	A	2	3	6.1	Geom	-	4.00	0.00	Y	Arm 2 Right	30.00
7/2	U	A	2	3	6.1	Geom	-	4.00	0.00	Y	Arm 2 Right	30.00
8/1	U		2	3	17.4	Inf	-	-	-	-	-	-
8/2	U		2	3	17.4	Inf	-	-	-	-	-	-
9/1	U		2	3	14.8	Inf	-	-	-	-	-	-
9/2	U		2	3	14.8	Inf	-	-	-	-	-	-

## Traffic Flow Groups

Flow Group	Start Time	End Time	Duration	Formula
1: '2031 with additional mez - AM'	08:00	09:00	01:00	
2: '2031 with additional mez - PM'	17:00	18:00	01:00	

**Scenario 1: '2031 with additional mez - AM'** (FG1: '2031 with additional mez - AM', Plan 1: 'Network Control Plan 1')

**Traffic Flows, Desired**

**Desired Flow :**

	Destination				
		A	B	C	Tot.
Origin	A	0	1575	935	2510
	B	1293	0	187	1480
	C	414	11	0	425
	Tot.	1707	1586	1122	4415

**Traffic Lane Flows**

Lane	Scenario 1: 2031 with additional mez - AM
<b>Junction: A508/Site Access</b>	
1/1	1075
1/2 (with short)	1435(In) 750(Out)
1/3 (short)	685
2/1	1080
2/2	506
3/1	437
3/2	685
4/1 (with short)	1480(In) 740(Out)
4/2 (short)	740
5/1	414
5/2	553
5/3	740
6/1	414
6/2 (with short)	11(In) 5(Out)
6/3 (short)	6
7/1	5
7/2	6
8/1	250
8/2	685
9/1	553
9/2	740

## Lane Saturation Flows

Junction: A508/Site Access								
Lane	Lane Width (m)	Gradient	Nearside Lane	Allowed Turns	Turning Radius (m)	Turning Prop.	Sat Flow (PCU/Hr)	Flared Sat Flow (PCU/Hr)
1/1 (A508 Notth)	3.65	0.00	Y	Arm 2 Ahead	22.00	100.0 %	1854	1854
1/2 (A508 Notth)	3.65	0.00	N	Arm 2 Ahead	25.00	66.7 %	2000	2000
				Arm 8 Right	25.00	33.3 %		
1/3 (A508 Notth)	3.65	0.00	N	Arm 8 Right	28.00	100.0 %	2012	2012
2/1	Infinite Saturation Flow						Inf	Inf
2/2	Infinite Saturation Flow						Inf	Inf
3/1	Infinite Saturation Flow						Inf	Inf
3/2	Infinite Saturation Flow						Inf	Inf
4/1 (A508 South)	3.50	0.00	Y	Arm 3 Left	30.00	25.3 %	1940	1940
				Arm 9 Ahead	Inf	74.7 %		
4/2 (A508 South)	3.50	0.00	N	Arm 9 Ahead	Inf	100.0 %	2105	2105
5/1	Infinite Saturation Flow						Inf	Inf
5/2	Infinite Saturation Flow						Inf	Inf
5/3	Infinite Saturation Flow						Inf	Inf
6/1 (Site Access)	3.50	0.00	Y	Arm 5 Left	30.00	100.0 %	1871	1871
6/2 (Site Access Lane 2)	Infinite Saturation Flow						Inf	Inf
6/3 (Site Access Lane 3)	Infinite Saturation Flow						Inf	Inf
7/1	4.00	0.00	Y	Arm 2 Right	30.00	100.0 %	1919	1919
7/2	4.00	0.00	Y	Arm 2 Right	30.00	100.0 %	1919	1919
8/1	Infinite Saturation Flow						Inf	Inf
8/2	Infinite Saturation Flow						Inf	Inf
9/1	Infinite Saturation Flow						Inf	Inf
9/2	Infinite Saturation Flow						Inf	Inf

**Scenario 2: '2031 with additional mez - PM'** (FG2: '2031 with additional mez - PM', Plan 1: 'Network Control Plan 1')

### Traffic Flows, Desired

Desired Flow :

	Destination				
		A	B	C	Tot.
Origin	A	0	1651	499	2150
	B	1311	0	101	1412
	C	1130	81	0	1211
	Tot.	2441	1732	600	4773

## Traffic Lane Flows

Lane	Scenario 2: 2031 with additional mez - PM
<b>Junction: A508/Site Access</b>	
1/1	1050
1/2 (with short)	1100(In) 751(Out)
1/3 (short)	349
2/1	1090
2/2	642
3/1	251
3/2	349
4/1 (with short)	1412(In) 708(Out)
4/2 (short)	704
5/1	1130
5/2	607
5/3	704
6/1	1130
6/2 (with short)	81(In) 40(Out)
6/3 (short)	41
7/1	40
7/2	41
8/1	150
8/2	349
9/1	607
9/2	704

## Lane Saturation Flows

Junction: A508/Site Access								
Lane	Lane Width (m)	Gradient	Nearside Lane	Allowed Turns	Turning Radius (m)	Turning Prop.	Sat Flow (PCU/Hr)	Flared Sat Flow (PCU/Hr)
1/1 (A508 Nothh)	3.65	0.00	Y	Arm 2 Ahead	22.00	100.0 %	1854	1854
1/2 (A508 Nothh)	3.65	0.00	N	Arm 2 Ahead	25.00	80.0 %	2000	2000
				Arm 8 Right	25.00	20.0 %		
1/3 (A508 Nothh)	3.65	0.00	N	Arm 8 Right	28.00	100.0 %	2012	2012
2/1	Infinite Saturation Flow						Inf	Inf
2/2	Infinite Saturation Flow						Inf	Inf
3/1	Infinite Saturation Flow						Inf	Inf
3/2	Infinite Saturation Flow						Inf	Inf
4/1 (A508 South)	3.50	0.00	Y	Arm 3 Left	30.00	14.3 %	1951	1951
				Arm 9 Ahead	Inf	85.7 %		
4/2 (A508 South)	3.50	0.00	N	Arm 9 Ahead	Inf	100.0 %	2105	2105
5/1	Infinite Saturation Flow						Inf	Inf
5/2	Infinite Saturation Flow						Inf	Inf
5/3	Infinite Saturation Flow						Inf	Inf
6/1 (Site Access)	3.50	0.00	Y	Arm 5 Left	30.00	100.0 %	1871	1871
6/2 (Site Access Lane 2)	Infinite Saturation Flow						Inf	Inf
6/3 (Site Access Lane 3)	Infinite Saturation Flow						Inf	Inf
7/1	4.00	0.00	Y	Arm 2 Right	30.00	100.0 %	1919	1919
7/2	4.00	0.00	Y	Arm 2 Right	30.00	100.0 %	1919	1919
8/1	Infinite Saturation Flow						Inf	Inf
8/2	Infinite Saturation Flow						Inf	Inf
9/1	Infinite Saturation Flow						Inf	Inf
9/2	Infinite Saturation Flow						Inf	Inf

Scenario 1: '2031 with additional mez - AM' (FG1: '2031 with additional mez - AM', Plan 1: 'Network Control Plan 1')

### Stage Sequence Diagram

#### Stage Stream: 1

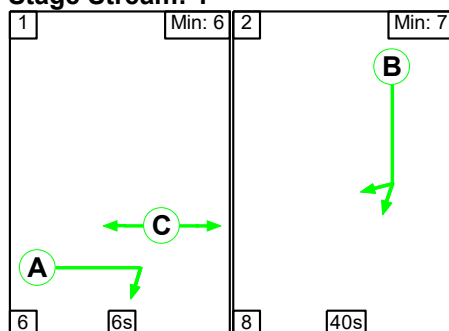

### Stage Timings

Stage Stream: 1

Stage	1	2
Duration	6	40
Change Point	0	12

### Signal Timings Diagram

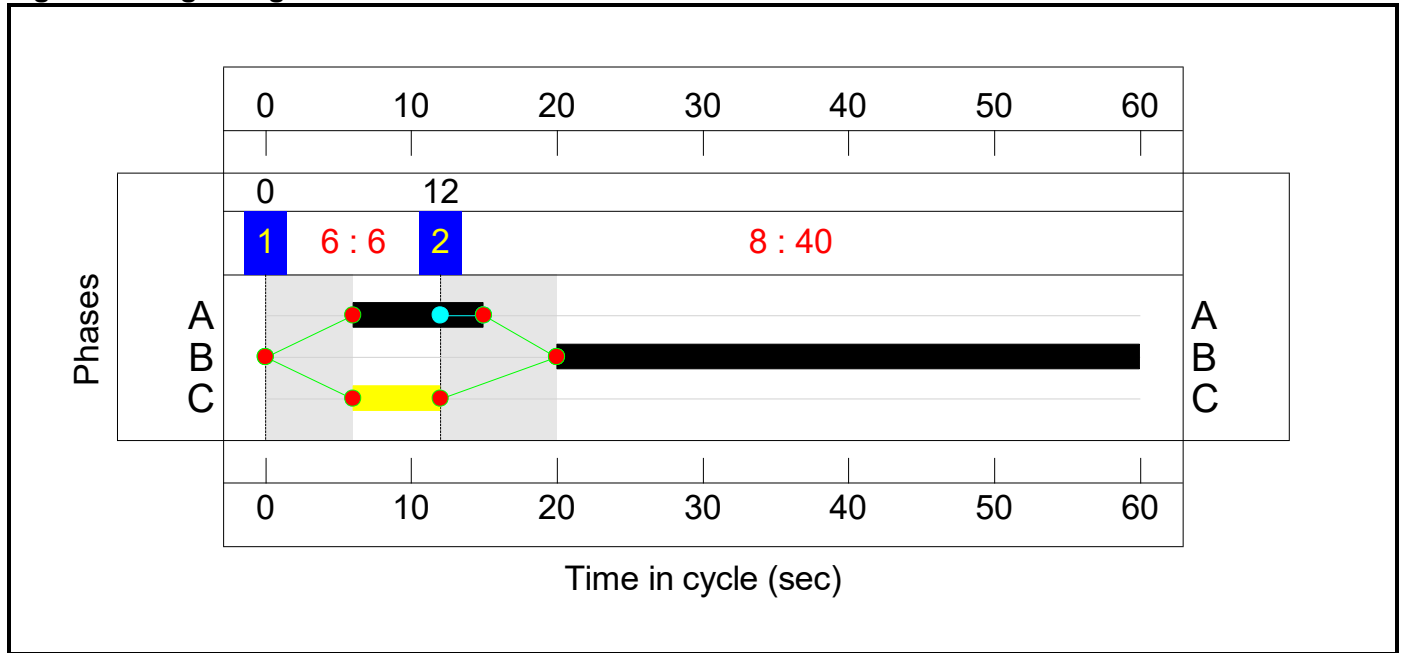

## Network Results

Item	Lane Description	Lane Type	Controller Stream	Position In Filtered Route	Full Phase	Arrow Phase	Num Greens	Total Green (s)	Arrow Green (s)	Demand Flow (pcu)	Sat Flow (pcu/Hr)	Capacity (pcu)	Deg Sat (%)
<b>Network</b>	-	-	<b>N/A</b>	-	-		-	-	-	-	-	-	<b>84.9%</b>
<b>A508/Site Access</b>	-	-	<b>N/A</b>	-	-		-	-	-	-	-	-	<b>84.9%</b>
1/1	A508 Notth Ahead	U	1	N/A	B		1	40	-	1075	1854	1267	84.9%
1/2+1/3	A508 Notth Ahead Right	U	1	N/A	B		1	40	-	1435	2000:2012	899+821	83.4 : 83.4%
4/1+4/2	A508 South Left Ahead	O	N/A	N/A	-		-	-	-	1480	1940:2105	872+872	84.8 : 84.8%
6/1	Site Access Left	U	N/A	N/A	-		-	-	-	414	1871	1871	22.1%
6/2+6/3	Site Access Ahead	O	N/A	N/A	-		-	-	-	11	Inf : Inf	536+573	0.9 : 1.0%
7/1	Right	U	1	N/A	A		1	9	-	5	1919	320	1.6%
7/2	Right	U	1	N/A	A		1	9	-	6	1919	320	1.9%
Item	Arriving (pcu)	Leaving (pcu)	Turners In Gaps (pcu)	Turners When Unopposed (pcu)	Turners In Intergreen (pcu)	Uniform Delay (pcuHr)	Rand + Oversat Delay (pcuHr)	Storage Area Uniform Delay (pcuHr)	Total Delay (pcuHr)	Av. Delay Per PCU (s/pcu)	Max. Back of Uniform Queue (pcu)	Rand + Oversat Queue (pcu)	Mean Max Queue (pcu)
<b>Network</b>	-	-	<b>2982</b>	<b>0</b>	<b>0</b>	<b>4.4</b>	<b>8.1</b>	<b>0.0</b>	<b>12.5</b>	-	-	-	-
<b>A508/Site Access</b>	-	-	<b>2982</b>	<b>0</b>	<b>0</b>	<b>4.4</b>	<b>8.1</b>	<b>0.0</b>	<b>12.5</b>	-	-	-	-
1/1	1075	1075	-	-	-	2.1	2.7	-	4.9	16.3	13.4	2.7	16.2
1/2+1/3	1435	1435	-	-	-	1.9	2.5	-	4.3	10.9	6.7	2.5	9.2
4/1+4/2	1480	1480	2960	0	0	0.3	2.7	-	3.0	7.4	6.0	2.7	8.7
6/1	414	414	-	-	-	0.0	0.1	-	0.1	1.2	0.0	0.1	0.1
6/2+6/3	11	11	22	0	0	0.0	0.0	-	0.0	1.6	0.0	0.0	0.0
7/1	5	5	-	-	-	0.0	0.0	-	0.0	27.0	0.1	0.0	0.1
7/2	6	6	-	-	-	0.0	0.0	-	0.0	27.0	0.1	0.0	0.1
C1 Stream: 1 PRC for Signalled Lanes (%)					6.1	Total Delay for Signalled Lanes (pcuHr):			9.29	Cycle Time (s): 60			
PRC Over All Lanes (%)					6.1	Total Delay Over All Lanes(pcuHr):			12.48				

Scenario 2: '2031 with additional mez - PM' (FG2: '2031 with additional mez - PM', Plan 1: 'Network Control Plan 1')

### Stage Sequence Diagram

Stage Stream: 1

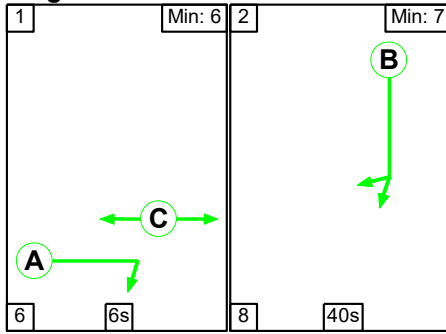

### Stage Timings

Stage Stream: 1

Stage	1	2
Duration	6	40
Change Point	0	12

### Signal Timings Diagram

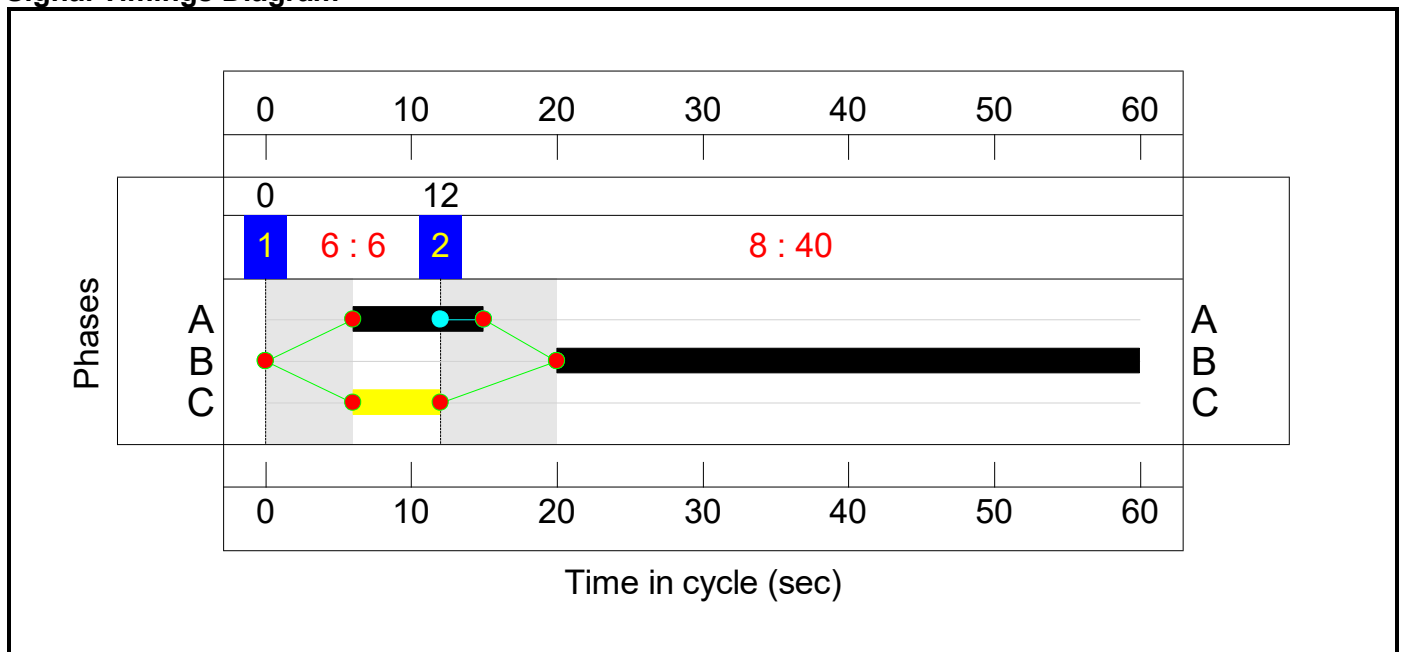

## Network Results

Item	Lane Description	Lane Type	Controller Stream	Position In Filtered Route	Full Phase	Arrow Phase	Num Greens	Total Green (s)	Arrow Green (s)	Demand Flow (pcu)	Sat Flow (pcu/Hr)	Capacity (pcu)	Deg Sat (%)
<b>Network</b>	-	-	<b>N/A</b>	-	-		-	-	-	-	-	-	<b>82.9%</b>
<b>A508/Site Access</b>	-	-	<b>N/A</b>	-	-		-	-	-	-	-	-	<b>82.9%</b>
1/1	A508 Notth Ahead	U	1	N/A	B		1	40	-	1050	1854	1267	82.9%
1/2+1/3	A508 Notth Ahead Right	U	1	N/A	B		1	40	-	1100	2000:2012	1057+491	71.1 : 71.1%
4/1+4/2	A508 South Left Ahead	O	N/A	N/A	-		-	-	-	1412	1951:2105	981+981	72.2 : 71.8%
6/1	Site Access Left	U	N/A	N/A	-		-	-	-	1130	1871	1871	60.4%
6/2+6/3	Site Access Ahead	O	N/A	N/A	-		-	-	-	81	Inf : Inf	567+567	7.1 : 7.2%
7/1	Right	U	1	N/A	A		1	9	-	40	1919	320	12.5%
7/2	Right	U	1	N/A	A		1	9	-	41	1919	320	12.8%
Item	Arriving (pcu)	Leaving (pcu)	Turners In Gaps (pcu)	Turners When Unopposed (pcu)	Turners In Intergreen (pcu)	Uniform Delay (pcuHr)	Rand + Oversat Delay (pcuHr)	Storage Area Uniform Delay (pcuHr)	Total Delay (pcuHr)	Av. Delay Per PCU (s/pcu)	Max. Back of Uniform Queue (pcu)	Rand + Oversat Queue (pcu)	Mean Max Queue (pcu)
<b>Network</b>	-	-	<b>2986</b>	<b>0</b>	<b>0</b>	<b>3.9</b>	<b>5.8</b>	<b>0.0</b>	<b>9.7</b>	-	-	-	-
<b>A508/Site Access</b>	-	-	<b>2986</b>	<b>0</b>	<b>0</b>	<b>3.9</b>	<b>5.8</b>	<b>0.0</b>	<b>9.7</b>	-	-	-	-
1/1	1050	1050	-	-	-	2.0	2.4	-	4.4	15.1	12.5	2.4	14.9
1/2+1/3	1100	1100	-	-	-	1.4	1.2	-	2.6	8.4	6.6	1.2	7.8
4/1+4/2	1412	1412	2824	0	0	0.0	1.3	-	1.3	3.3	0.6	1.3	1.9
6/1	1130	1130	-	-	-	0.0	0.8	-	0.8	2.4	0.0	0.8	0.8
6/2+6/3	81	81	162	0	0	0.0	0.0	-	0.0	1.7	0.0	0.0	0.0
7/1	40	40	-	-	-	0.2	0.1	-	0.3	27.7	0.6	0.1	0.6
7/2	41	41	-	-	-	0.2	0.1	-	0.3	27.8	0.6	0.1	0.7
C1			Stream: 1 PRC for Signalled Lanes (%):		8.6	Total Delay for Signalled Lanes (pcuHr):		7.60	Cycle Time (s):		60		
			PRC Over All Lanes (%):		8.6	Total Delay Over All Lanes(pcuHr):		9.67					

## APPENDIX 3

# NATIONAL HIGHWAYS CORRESPONDENCE

## Stuart Dunhill

---

**From:** Martin Seldon <Martin.Seldon@nationalhighways.co.uk>  
**Sent:** 15 January 2025 16:55  
**To:** Stuart Dunhill  
**Cc:** Mark Higgins  
**Subject:** RE: Northampton Gateway SRFI - proposed DCO amendment

Hi Stuart,

We have reviewed your email below and are content with the explanation provided regarding the coding for the A508 / site access roundabout. Based on our review, we do not expect the access roundabout to result in any blocking back to the M1 J15. As such, we have no outstanding comments to be addressed from your end.

We will shortly issue a 'no objection' response to the proposed amendment, to the DCO application for the Northampton Gateway SRFI development, to increase the mezzanine floor space.

Kind regards

### **Martin Seldon, Spatial Planner**

National Highways | The Cube | 199 Wharfside Street | Birmingham | B1 1RN

**Tel:** +44 (0) 300 4703345 | **Mobile:** + 44 (0) 7787 321 881

**Web:** [www.nationalhighways.co.uk](http://www.nationalhighways.co.uk)

**GTN:** 0300 470 3345

For information about our engagement with the planning system please visit: : <https://nationalhighways.co.uk/our-roads/planning-and-the-strategic-road-network-in-england/>

---

**From:** Stuart Dunhill <Stuart.Dunhill@ADCInfrastructure.com>  
**Sent:** 23 December 2024 11:21  
**To:** Martin Seldon <Martin.Seldon@nationalhighways.co.uk>  
**Cc:** Mark Higgins <Mark.Higgins@ADCInfrastructure.com>  
**Subject:** RE: Northampton Gateway SRFI - proposed DCO amendment

Hi Martin,

Many thanks for the below response.

We note that you are now content with the submission regarding M1 Junction 15. Can you confirm therefore that NH would not object to the proposed amendment to the DCO to increase the mezzanine floor space?

Regarding the site access junction, whilst this is not part of the SRN and is the responsibility of the local highway authority, we note that you are also content with the submission, other than point 4 below which we explain in the following paragraph.

### **A508/Site access gyratory**

As confirmed in point 4 below, we have used ARCADY calculated slope and intercept values for the give way parameters on the A508 south arm. This is appropriate as traffic flows on this arm are high and the operation of the arm is material to the overall operation of the site access junction. However, for the site access right turn, we have used the default parameters suggested by JCT. The reason for this is that the traffic volumes using the site access right turn are very low, with only 11 pcus (no HGVs) turning right out of the site in the AM peak hour, and only 81 pcus (no HGVs) turning right out of the site in the PM peak hour. The right turn operates with significant spare capacity in both peaks, and it does not have a material impact on the overall operation of the site access junction. Given the very low traffic flows, the use of the default give way parameters is in our view a reasonable modelling decision.

Please can you confirm that this addresses your remaining question regarding the site access.

We look forward to hearing from you.

Kind regards

**Stuart Dunhill** BEng(Hons) PhD CEng MICE  
Director – [ADC Infrastructure Limited](#)  
mob: 07968411585

4<sup>th</sup> Floor, City Buildings, 34-36 Carrington Street, Nottingham NG1 7FG  
[Stuart.Dunhill@ADCInfrastructure.com](mailto:Stuart.Dunhill@ADCInfrastructure.com)  
[www.ADCInfrastructure.com](http://www.ADCInfrastructure.com)

---

**From:** Martin Seldon <[Martin.Seldon@nationalhighways.co.uk](mailto:Martin.Seldon@nationalhighways.co.uk)>  
**Sent:** 20 December 2024 10:40  
**To:** Mark Higgins <[Mark.Higgins@ADCInfrastructure.com](mailto:Mark.Higgins@ADCInfrastructure.com)>

Cc: Stuart Dunhill <[Stuart.Dunhill@ADCInfrastructure.com](mailto:Stuart.Dunhill@ADCInfrastructure.com)>

Subject: RE: Northampton Gateway SRFI - proposed DCO amendment

Hi Mark

Hope you are keeping well.

Thank you for getting back to us with the response note dated 2 December 2024 and the revised LinSig files.

As part of this audit, we have reviewed the following files:

1. 3519-ADC-ZZ-XX-DR-Z-0100\_Proposed mitigation.dwg
2. 240514 Proposed site access mitigation.dwg
3. 241129 M1 Junction 15 – additional mez test.lsg3x
4. 241129 site access gyratory – proposed mitigation.lsg3x
5. 241129 SLP NG DCO Amendment – ADC3519.pdf

Based on our review of the comments noted in the response note alongside the above files, we have set out our comments below for your consideration.

### **M1 Junction 15**

We are content with your response, together with the changes made to the model and can confirm that we have no further comments to make.

### **A508/ Site Access Gyratory**

1. Traffic flows: We are content with the reasoning provided and adjustments made to the model and have no further comments to make.
2. Model structure: As above (all outstanding comments can be considered as closed).
3. Intergreen measurements: We consider your response to be acceptable and therefore, have no further comments to make.
4. Give way data: We have reviewed Appendix 48 of the Transport Assessment, submitted in support of the original DCO application and are unable to match the Slope and Intercept values, with the coefficient and Max. Flow values entered in LinSig. While ARCADY calculates Slope and Intercept values per approach, they need to be entered into LinSig per lane; therefore, the calculated values need to be spread across each lane as appropriate. Whilst the LinSig values on the A508 South approach seem to be based on the calculations, the values for the site access arm seem to be based on the default values of 1000 / 0.33 suggested by JCT. Please can you explain why

you have not used the calculated values on this arm? Please can you therefore explain how the values entered in LinSig have been determined?

National Highways will be in a better position to review the model outputs and the impact of the amendment proposed, following the addressing of the above comment.

Kind regards

**Martin Seldon, Spatial Planner**

National Highways | The Cube | 199 Wharfside Street | Birmingham | B1 1RN

**Tel:** +44 (0) 300 4703345 | **Mobile:** + 44 (0) 7787 321 881

Web: [www.nationalhighways.co.uk](http://www.nationalhighways.co.uk)

GTN: 0300 470 3345

For information about our engagement with the planning system please visit: : <https://nationalhighways.co.uk/our-roads/planning-and-the-strategic-road-network-in-england/>

---

**From:** Mark Higgins <[Mark.Higgins@ADCinfrastructure.com](mailto:Mark.Higgins@ADCinfrastructure.com)>

**Sent:** 05 December 2024 14:45

**To:** Martin Seldon <[Martin.Seldon@nationalhighways.co.uk](mailto:Martin.Seldon@nationalhighways.co.uk)>

**Cc:** Stuart Dunhill <[Stuart.Dunhill@ADCinfrastructure.com](mailto:Stuart.Dunhill@ADCinfrastructure.com)>

**Subject:** RE: Northampton Gateway SRFI - proposed DCO amendment

Hi Martin

Apologies, please find the drawing attached, along with the xref.

Many thanks

Mark

**Mark Higgins** MEng(Hons) MCIHT

Associate Director

ADC Infrastructure Limited

4<sup>th</sup> Floor, City Buildings, 34-36 Carrington Street, Nottingham NG1 7FG

tel: 07532112800

[Mark.Higgins@ADCInfrastructure.com](mailto:Mark.Higgins@ADCInfrastructure.com)

[www.ADCInfrastructure.com](http://www.ADCInfrastructure.com)

---

**From:** Martin Seldon <[Martin.Seldon@nationalhighways.co.uk](mailto:Martin.Seldon@nationalhighways.co.uk)>

**Sent:** 05 December 2024 12:06

**To:** Mark Higgins <[Mark.Higgins@ADCInfrastructure.com](mailto:Mark.Higgins@ADCInfrastructure.com)>

**Cc:** Stuart Dunhill <[Stuart.Dunhill@ADCInfrastructure.com](mailto:Stuart.Dunhill@ADCInfrastructure.com)>

**Subject:** RE: Northampton Gateway SRFI - proposed DCO amendment

Hi Mark

Hope you are keeping well.

Your letter states that drawing 3519-ADC-ZZ- XX-DR-Z-0100, of the A508/Site Access Gyratory, will also be provided by dwg via email. However, I've yet to receive this and should be grateful if you would forward the drawing, to assist with our review.

Kind regards

**Martin Seldon, Spatial Planner**

National Highways | The Cube | 199 Wharfside Street | Birmingham | B1 1RN

**Tel:** +44 (0) 300 4703345 | **Mobile:** + 44 (0) 7787 321 881

**Web:** [www.nationalhighways.co.uk](http://www.nationalhighways.co.uk)

**GTN:** 0300 470 3345

For information about our engagement with the planning system please visit : <https://nationalhighways.co.uk/our-roads/planning-and-the-strategic-road-network-in-england/>

---

**From:** Mark Higgins <[Mark.Higgins@ADCInfrastructure.com](mailto:Mark.Higgins@ADCInfrastructure.com)>

**Sent:** 02 December 2024 16:14

**To:** Martin Seldon <[Martin.Seldon@nationalhighways.co.uk](mailto:Martin.Seldon@nationalhighways.co.uk)>

**Cc:** Stuart Dunhill <[Stuart.Dunhill@ADCInfrastructure.com](mailto:Stuart.Dunhill@ADCInfrastructure.com)>

**Subject:** RE: Northampton Gateway SRFI - proposed DCO amendment

Hi Martin

Thank you very much for your comments on our TA Addendum report and the LinSig modelling. We have considered the points raised and updated the LinSig models where appropriate. The attached letter details our response, and the revised model files are also attached for convenience.

Please let me know if you require anything further.

Many thanks

Mark

**Mark Higgins** MEng(Hons) MCIHT  
Associate Director

ADC Infrastructure Limited  
4<sup>th</sup> Floor, City Buildings, 34-36 Carrington Street, Nottingham NG1 7FG  
tel: 07532112800  
[Mark.Higgins@ADCInfrastructure.com](mailto:Mark.Higgins@ADCInfrastructure.com)  
[www.ADCInfrastructure.com](http://www.ADCInfrastructure.com)

---

**From:** Martin Seldon <[Martin.Seldon@nationalhighways.co.uk](mailto:Martin.Seldon@nationalhighways.co.uk)>  
**Sent:** 19 November 2024 15:06  
**To:** Mark Higgins <[Mark.Higgins@ADCInfrastructure.com](mailto:Mark.Higgins@ADCInfrastructure.com)>  
**Cc:** Stuart Dunhill <[Stuart.Dunhill@ADCInfrastructure.com](mailto:Stuart.Dunhill@ADCInfrastructure.com)>  
**Subject:** RE: Northampton Gateway SRFI - proposed DCO amendment

Hi Mark

Thank you for your email containing the updated TA Addendum and revised LinSig files.

Based on our review, we have the following comments:

### **M1 Junction 15**

1. Model Structure: Please can you clarify whether Arm 3, Lane 1 should be connected to Arm 18, Lane 1, rather than from Arm 3, Lane 2? The nearside lane of this arm (Arm 3) is marked for both M1(S) and Grange Park, but the LinSig model allows only traffic into Saxon Avenue.

2. Traffic Flows: It is our understanding that, Flow Group 7 (2031 J1d Dev AM Peak) and Flow Group 8 (2031 J1d Dev PM Peak) of the old model (180221 M1 Junction 15 Mitigation with WL.lsg3x), have been copied across to the new model as Flow Group 1 (2031 background – AM) and Flow Group 2 (2031 background – PM). Please can you confirm that this is the case?

If the above flow assumption is correct, please can you explain why the new model sees the introduction of M1 North to M1 North U-turning flows in the AM and PM peaks? We note that this movement was not included in the previous revision of the model.

3. Signal Controllers:

- a. Controller 1 – North Side: Phase G has been coded into the LinSig model with a minimum green time of 5 seconds, however the controller specification document has a minimum green of 7 seconds. While this is not expected to change the model results, please can this be updated.
- b. Controller 2 – South Side: The controller specification document shows a phase delay value for Phase F, but this does not appear to have been coded into the LinSig model. Is there a reason for this?

We have also attached the signal controller information used for our review purposes for your consideration.

### **A508/ Site Access Gyratory**

Please can you provide us with a scaled drawing (preferably in CAD format) so that the geometric parameters entered in the model can be verified.

1. Traffic Flows: There seems to be an inconsistency in traffic flows on the A508 between this junction and the M1 Junction. The flow leaving or entering this roundabout on Arm A does not arrive or leave the M1 model on Arm D. These differences have been highlighted in Diagrams 7 and 8, but it is not clear why these discrepancies occur.

In the PM Peak, the model has assigned zero flow to the nearside lane of the southern circulatory (Arm 8, Lane 1). Please can you confirm this is realistic? Would no traffic use the nearside lane either by merging across or being fed from the upstream middle lane? If flows are not correctly assigned to the circulatory lanes, it could possibly affect the predicted level of queuing on adjacent approach to the roundabout. With the flow levels on the A508 Southbound approach and the length of the offside flare, it may not be appropriate to rely on the LinSig Delay Based Assignment. A certain degree of manual adjustments may be more realistic, depending on how the southbound approach offside flare is used once the initial queue clears following the start of the green period.

2. Model Structure: The northern circulatory (Arm 7), adjacent to the A508 Southbound approach, only shows a single lane. However, but Figure 7 in the “DCO Amendment” report shows it as two lanes. Is there a reason for modelling the arm in that way?

The site access arm (Arm 6) does not show the two lanes that enter the roundabout, but just a single lane (Arm 6, lane 2). Please can you explain why it has been modelled as a single lane?

The LinSig model does not include the pedestrian crossings located on the A508 Northbound exit and the left turn on the site access arm. Please can you justify the exclusion of these two crossings from the model?

3. Intergreen measurements: Although a scaled drawing has not been supplied, it appears that the intergreen value of 8 seconds on the A508 Southbound entry pedestrian crossing (Phase C) may be too low, as pedestrians have to walk across three lanes of traffic. Please can you confirm this value is correct? For our reference, are you able to supply us with the existing controller specification documents for the signalised crossings currently located at the roundabout?
4. Give Way Data: Please can you set out how the give way parameters on the A508 South (Arm 4) and Site Access (Arm 6) approaches have been determined? The A508 South approach seems to have calculated values, whilst the site access arm uses the standard values suggested by JCT. We would recommend you calculate the values for each lane and then show us in a supporting CAD file, the geometric parameters used to calculate the Slope and Intercept values that are used in the LinSig model, as the Coefficient and Maximum Flow values respectively.

Kind regards

**Martin Seldon, Spatial Planner**

National Highways | The Cube | 199 Wharfside Street | Birmingham | B1 1RN

**Tel:** +44 (0) 300 4703345 | **Mobile:** + 44 (0) 7787 321 881

Web: [www.nationalhighways.co.uk](http://www.nationalhighways.co.uk)

GTN: 0300 470 3345

For information about our engagement with the planning system please visit: : <https://nationalhighways.co.uk/our-roads/planning-and-the-strategic-road-network-in-england/>

---

**From:** Mark Higgins <[Mark.Higgins@ADCinfrastructure.com](mailto:Mark.Higgins@ADCinfrastructure.com)>

**Sent:** 01 November 2024 12:00

**To:** Martin Seldon <[Martin.Seldon@nationalhighways.co.uk](mailto:Martin.Seldon@nationalhighways.co.uk)>

**Cc:** Stuart Dunhill <[Stuart.Dunhill@ADCinfrastructure.com](mailto:Stuart.Dunhill@ADCinfrastructure.com)>

**Subject:** RE: Northampton Gateway SRFI - proposed DCO amendment

Hello Martin,

Stuart has passed your email below on to me.

I have investigated the cause of the discrepancy between the modelled flow groups presented in the Technical Note and the '2031 J1d Dev' traffic flows shown at Appendix 46 of the TA. The modelling of M1 J15 in the TA included the A45/Watering Lane junction (with Watering Lane represented by zone F), which has been stripped out of the current model. The discrepancy has been traced to the re-assignment of the Watering Lane/zone F flows across the matrices.

The error has been corrected in the LinSig model and the Technical Note revised accordingly. Hence, please find attached report **ADC3517-RP-A-v3** for your consideration. I have also attached the LinSig models for convenience.

Kind regards

Mark

**Mark Higgins** MEng(Hons) MCIHT  
Associate Director

ADC Infrastructure Limited  
4<sup>th</sup> Floor, City Buildings, 34-36 Carrington Street, Nottingham NG1 7FG  
tel: 07532112800  
[Mark.Higgins@ADCInfrastructure.com](mailto:Mark.Higgins@ADCInfrastructure.com)  
[www.ADCInfrastructure.com](http://www.ADCInfrastructure.com)

---

**From:** Martin Seldon <[Martin.Seldon@nationalhighways.co.uk](mailto:Martin.Seldon@nationalhighways.co.uk)>  
**Sent:** 31 October 2024 14:40  
**To:** Stuart Dunhill <[Stuart.Dunhill@ADCInfrastructure.com](mailto:Stuart.Dunhill@ADCInfrastructure.com)>  
**Subject:** RE: Northampton Gateway SRFI - proposed DCO amendment

Hi Stuart

Hope you are keeping well too.

Apologies for the delay in responding to you.

Having reviewed the TA Addendum, we note that the amendment is to increase the mezzanine floorspace of the development by 111,480 sqm to cater to the changes in market demand. We acknowledge that the trip rates and trip distribution remain the same as agreed earlier during the original DCO submission. However, we note that you have utilised the higher trip rates corresponding to the Swan Valley proxy site, for light vehicles corresponding to 16:00 to 17:00 hours for the PM peak.

The increase in mezzanine floorspace is expected to generate 105 and 128 two-way vehicles (which equates to 137 and 158 PCUs) during the standard AM and PM peak hours. This translates to the following increase in development trips passing through the M1 J15 and towards the A45 North, during the AM and PM peak hours respectively:

- a) M1 J15 - 122 and 140 PCUs
- b) Towards A45 north – 53 and 72 PCUs

We appreciate that you have undertaken a LinSig assessment for M1 J15, by utilising the 2031 with-development traffic flows from the original TA submission. However, we have noted some differences in flow values on the M1 north arm, when compared to the '2031 J1d Dev' flows available in Appendix 46 of the TA. Can you please check and get back to us on this? The network layout largely remains the same with a few changes noted in the physical length coded for some of the lanes; however, these are not expected to be significant enough to result in any material changes to the output. We recommend that you provide the model files for our review, along with the earlier approved LinSig model developed in 2018 (Appendix 46 of the TA). We note that the staging and phasing arrangements have been amended, to match the on-street controller function and we welcome this. We will provide a full response following the review of the model files.

Kind regards

**Martin Seldon, Spatial Planner**

National Highways | The Cube | 199 Wharfside Street | Birmingham | B1 1RN

**Tel:** +44 (0) 300 4703345 | **Mobile:** + 44 (0) 7787 321 881

**Web:** [www.nationalhighways.co.uk](http://www.nationalhighways.co.uk)

**GTN:** 0300 470 3345

For information about our engagement with the planning system please visit: : <https://nationalhighways.co.uk/our-roads/planning-and-the-strategic-road-network-in-england/>

---

**From:** Stuart Dunhill <[Stuart.Dunhill@ADCInfrastructure.com](mailto:Stuart.Dunhill@ADCInfrastructure.com)>

**Sent:** 31 October 2024 13:19

**To:** Martin Seldon <[Martin.Seldon@nationalhighways.co.uk](mailto:Martin.Seldon@nationalhighways.co.uk)>

**Subject:** RE: Northampton Gateway SRFI - proposed DCO amendment

Hi Martin,

I trust all is well.

Could you provide an update on where you are with reviewing our technical note and likely timescales for a response, please.

Many thanks

**Stuart Dunhill** BEng(Hons) PhD CEng MICE  
Director – [ADC Infrastructure Limited](#)  
mob: 07968411585

4<sup>th</sup> Floor, City Buildings, 34-36 Carrington Street, Nottingham NG1 7FG  
[Stuart.Dunhill@ADCInfrastructure.com](mailto:Stuart.Dunhill@ADCInfrastructure.com)  
[www.ADCInfrastructure.com](http://www.ADCInfrastructure.com)

---

**From:** Stuart Dunhill <[Stuart.Dunhill@ADCInfrastructure.com](mailto:Stuart.Dunhill@ADCInfrastructure.com)>  
**Sent:** 11 October 2024 12:09  
**To:** Martin Seldon <[Martin.Seldon@nationalhighways.co.uk](mailto:Martin.Seldon@nationalhighways.co.uk)>  
**Subject:** RE: Northampton Gateway SRFI - proposed DCO amendment

Hello Martin,

Thank you for the below update. I am meeting again with Segro next Friday morning (18<sup>th</sup>), and was wondering whether you're likely to be able to respond by then?

Many thanks

**Stuart Dunhill** BEng(Hons) PhD CEng MICE  
Director – [ADC Infrastructure Limited](#)  
mob: 07968411585

4<sup>th</sup> Floor, City Buildings, 34-36 Carrington Street, Nottingham NG1 7FG  
[Stuart.Dunhill@ADCInfrastructure.com](mailto:Stuart.Dunhill@ADCInfrastructure.com)  
[www.ADCInfrastructure.com](http://www.ADCInfrastructure.com)

---

**From:** Martin Seldon <[Martin.Seldon@nationalhighways.co.uk](mailto:Martin.Seldon@nationalhighways.co.uk)>  
**Sent:** 30 September 2024 16:27  
**To:** Stuart Dunhill <[Stuart.Dunhill@ADCInfrastructure.com](mailto:Stuart.Dunhill@ADCInfrastructure.com)>  
**Subject:** RE: Northampton Gateway SRFI - proposed DCO amendment

Hi Stuart

Thank you for your e-mail and hope you are keeping well too.

We'll review the report and I shall respond more fully shortly.

Kind regards

**Martin Seldon, Spatial Planner**

National Highways | The Cube | 199 Wharfside Street | Birmingham | B1 1RN

**Tel:** +44 (0) 300 4703345 | **Mobile:** + 44 (0) 7787 321 881

Web: [www.nationalhighways.co.uk](http://www.nationalhighways.co.uk)

GTN: 0300 470 3345

For information about our engagement with the planning system please visit: : <https://nationalhighways.co.uk/our-roads/planning-and-the-strategic-road-network-in-england/>

---

**From:** Stuart Dunhill <[Stuart.Dunhill@ADCInfrastructure.com](mailto:Stuart.Dunhill@ADCInfrastructure.com)>

**Sent:** Thursday, September 19, 2024 4:12 PM

**To:** Martin Seldon <[Martin.Seldon@nationalhighways.co.uk](mailto:Martin.Seldon@nationalhighways.co.uk)>

**Cc:** Kate Bedson <[Kate.Bedson@segro.com](mailto:Kate.Bedson@segro.com)>; Ian Rigby <[Ian.Rigby@segro.com](mailto:Ian.Rigby@segro.com)>; Steve Harley ([steve@oxalisplanning.co.uk](mailto:steve@oxalisplanning.co.uk)) <[steve@oxalisplanning.co.uk](mailto:steve@oxalisplanning.co.uk)>

**Subject:** Northampton Gateway SRFI - proposed DCO amendment

Hello Martin,

I trust that you are well.

Segro wish to apply for an amendment to the DCO at Northampton Gateway SRFI. The amendment is required in response to changes in market demand, as occupiers now require much greater volumes of mezzanine floor space than was previously the case. SEGRO are therefore seeking to amend the maximum amount of mezzanine floor space that is permitted under the DCO. This will safeguard the future build out of the SRFI site by ensuring that it can provide an appropriate mix of floor space and hence remain attractive to occupiers.

SEGRO are seeking to increase the amount of mezzanine floor space that can be delivered at Northampton Gateway SRFI by 1.2 million sqft (111,480 sqm). We have therefore prepared the attached report (reference **ADC3519-RP-A-v2 'SPL NG DCO Amendment'**) to assess the implications of this on the transport infrastructure.

Subject to an improvement scheme at the SRFI site access roundabout on the A508, the report concludes that the transport impacts arising of the increased mezzanine floor space would continue to be mitigated by the consented highway and transport infrastructure, and that the residual impacts are reduced to acceptable levels. Accordingly, there should be no highways objection to the proposed DCO amendment.

We would like to reach agreement with National Highways ahead of submitting the DCO amendment. Accordingly, we would welcome your review of the attached report.

I look forward to hearing from you. However, please don't hesitate to contact me, should you have any questions or require any further information.

Kind regards

**Stuart Dunhill** BEng(Hons) PhD CEng MICE  
Director – [ADC Infrastructure Limited](#)  
mob: 07968411585

4<sup>th</sup> Floor, City Buildings, 34-36 Carrington Street, Nottingham NG1 7FG  
[Stuart.Dunhill@ADCInfrastructure.com](mailto:Stuart.Dunhill@ADCInfrastructure.com)  
[www.ADCInfrastructure.com](http://www.ADCInfrastructure.com)

This email may contain information which is confidential and is intended only for use of the recipient/s named above. If you are not an intended recipient, you are hereby notified that any copying, distribution, disclosure, reliance upon or other use of the contents of this email is strictly prohibited. If you have received this email in error, please notify the sender and destroy it.

**National Highways Limited | General enquiries: 0300 123 5000 | National Traffic Operations Centre, 3 Ridgeway, Quinton Business Park, Birmingham B32 1AF | <https://nationalhighways.co.uk> | [info@nationalhighways.co.uk](mailto:info@nationalhighways.co.uk)**

*Registered in England and Wales no 9346363 | Registered Office: Bridge House, 1 Walnut Tree Close, Guildford, Surrey GU1 4LZ*

Consider the environment. Please don't print this e-mail unless you really need to.

## APPENDIX 3

# NATIONAL HIGHWAYS CORRESPONDENCE

## Stuart Dunhill

---

**From:** Martin Seldon <Martin.Seldon@nationalhighways.co.uk>  
**Sent:** 15 January 2025 16:55  
**To:** Stuart Dunhill  
**Cc:** Mark Higgins  
**Subject:** RE: Northampton Gateway SRFI - proposed DCO amendment

Hi Stuart,

We have reviewed your email below and are content with the explanation provided regarding the coding for the A508 / site access roundabout. Based on our review, we do not expect the access roundabout to result in any blocking back to the M1 J15. As such, we have no outstanding comments to be addressed from your end.

We will shortly issue a 'no objection' response to the proposed amendment, to the DCO application for the Northampton Gateway SRFI development, to increase the mezzanine floor space.

Kind regards

### **Martin Seldon, Spatial Planner**

National Highways | The Cube | 199 Wharfside Street | Birmingham | B1 1RN

**Tel:** +44 (0) 300 4703345 | **Mobile:** + 44 (0) 7787 321 881

**Web:** [www.nationalhighways.co.uk](http://www.nationalhighways.co.uk)

**GTN:** 0300 470 3345

For information about our engagement with the planning system please visit: : <https://nationalhighways.co.uk/our-roads/planning-and-the-strategic-road-network-in-england/>

---

**From:** Stuart Dunhill <Stuart.Dunhill@ADCInfrastructure.com>  
**Sent:** 23 December 2024 11:21  
**To:** Martin Seldon <Martin.Seldon@nationalhighways.co.uk>  
**Cc:** Mark Higgins <Mark.Higgins@ADCInfrastructure.com>  
**Subject:** RE: Northampton Gateway SRFI - proposed DCO amendment

Hi Martin,

Many thanks for the below response.

We note that you are now content with the submission regarding M1 Junction 15. Can you confirm therefore that NH would not object to the proposed amendment to the DCO to increase the mezzanine floor space?

Regarding the site access junction, whilst this is not part of the SRN and is the responsibility of the local highway authority, we note that you are also content with the submission, other than point 4 below which we explain in the following paragraph.

### **A508/Site access gyratory**

As confirmed in point 4 below, we have used ARCADY calculated slope and intercept values for the give way parameters on the A508 south arm. This is appropriate as traffic flows on this arm are high and the operation of the arm is material to the overall operation of the site access junction. However, for the site access right turn, we have used the default parameters suggested by JCT. The reason for this is that the traffic volumes using the site access right turn are very low, with only 11 pcus (no HGVs) turning right out of the site in the AM peak hour, and only 81 pcus (no HGVs) turning right out of the site in the PM peak hour. The right turn operates with significant spare capacity in both peaks, and it does not have a material impact on the overall operation of the site access junction. Given the very low traffic flows, the use of the default give way parameters is in our view a reasonable modelling decision.

Please can you confirm that this addresses your remaining question regarding the site access.

We look forward to hearing from you.

Kind regards

**Stuart Dunhill** BEng(Hons) PhD CEng MICE  
Director – [ADC Infrastructure Limited](#)  
mob: 07968411585

4<sup>th</sup> Floor, City Buildings, 34-36 Carrington Street, Nottingham NG1 7FG  
[Stuart.Dunhill@ADCInfrastructure.com](mailto:Stuart.Dunhill@ADCInfrastructure.com)  
[www.ADCInfrastructure.com](http://www.ADCInfrastructure.com)

---

**From:** Martin Seldon <[Martin.Seldon@nationalhighways.co.uk](mailto:Martin.Seldon@nationalhighways.co.uk)>  
**Sent:** 20 December 2024 10:40  
**To:** Mark Higgins <[Mark.Higgins@ADCInfrastructure.com](mailto:Mark.Higgins@ADCInfrastructure.com)>

Cc: Stuart Dunhill <[Stuart.Dunhill@ADCInfrastructure.com](mailto:Stuart.Dunhill@ADCInfrastructure.com)>

Subject: RE: Northampton Gateway SRFI - proposed DCO amendment

Hi Mark

Hope you are keeping well.

Thank you for getting back to us with the response note dated 2 December 2024 and the revised LinSig files.

As part of this audit, we have reviewed the following files:

1. 3519-ADC-ZZ-XX-DR-Z-0100\_Proposed mitigation.dwg
2. 240514 Proposed site access mitigation.dwg
3. 241129 M1 Junction 15 – additional mez test.lsg3x
4. 241129 site access gyratory – proposed mitigation.lsg3x
5. 241129 SLP NG DCO Amendment – ADC3519.pdf

Based on our review of the comments noted in the response note alongside the above files, we have set out our comments below for your consideration.

### **M1 Junction 15**

We are content with your response, together with the changes made to the model and can confirm that we have no further comments to make.

### **A508/ Site Access Gyratory**

1. Traffic flows: We are content with the reasoning provided and adjustments made to the model and have no further comments to make.
2. Model structure: As above (all outstanding comments can be considered as closed).
3. Intergreen measurements: We consider your response to be acceptable and therefore, have no further comments to make.
4. Give way data: We have reviewed Appendix 48 of the Transport Assessment, submitted in support of the original DCO application and are unable to match the Slope and Intercept values, with the coefficient and Max. Flow values entered in LinSig. While ARCADY calculates Slope and Intercept values per approach, they need to be entered into LinSig per lane; therefore, the calculated values need to be spread across each lane as appropriate. Whilst the LinSig values on the A508 South approach seem to be based on the calculations, the values for the site access arm seem to be based on the default values of 1000 / 0.33 suggested by JCT. Please can you explain why

you have not used the calculated values on this arm? Please can you therefore explain how the values entered in LinSig have been determined?

National Highways will be in a better position to review the model outputs and the impact of the amendment proposed, following the addressing of the above comment.

Kind regards

**Martin Seldon, Spatial Planner**

National Highways | The Cube | 199 Wharfside Street | Birmingham | B1 1RN

**Tel:** +44 (0) 300 4703345 | **Mobile:** + 44 (0) 7787 321 881

Web: [www.nationalhighways.co.uk](http://www.nationalhighways.co.uk)

GTN: 0300 470 3345

For information about our engagement with the planning system please visit: : <https://nationalhighways.co.uk/our-roads/planning-and-the-strategic-road-network-in-england/>

---

**From:** Mark Higgins <[Mark.Higgins@ADCinfrastructure.com](mailto:Mark.Higgins@ADCinfrastructure.com)>

**Sent:** 05 December 2024 14:45

**To:** Martin Seldon <[Martin.Seldon@nationalhighways.co.uk](mailto:Martin.Seldon@nationalhighways.co.uk)>

**Cc:** Stuart Dunhill <[Stuart.Dunhill@ADCinfrastructure.com](mailto:Stuart.Dunhill@ADCinfrastructure.com)>

**Subject:** RE: Northampton Gateway SRFI - proposed DCO amendment

Hi Martin

Apologies, please find the drawing attached, along with the xref.

Many thanks

Mark

**Mark Higgins** MEng(Hons) MCIHT

Associate Director

ADC Infrastructure Limited

4<sup>th</sup> Floor, City Buildings, 34-36 Carrington Street, Nottingham NG1 7FG

tel: 07532112800

[Mark.Higgins@ADCInfrastructure.com](mailto:Mark.Higgins@ADCInfrastructure.com)

[www.ADCInfrastructure.com](http://www.ADCInfrastructure.com)

---

**From:** Martin Seldon <[Martin.Seldon@nationalhighways.co.uk](mailto:Martin.Seldon@nationalhighways.co.uk)>

**Sent:** 05 December 2024 12:06

**To:** Mark Higgins <[Mark.Higgins@ADCInfrastructure.com](mailto:Mark.Higgins@ADCInfrastructure.com)>

**Cc:** Stuart Dunhill <[Stuart.Dunhill@ADCInfrastructure.com](mailto:Stuart.Dunhill@ADCInfrastructure.com)>

**Subject:** RE: Northampton Gateway SRFI - proposed DCO amendment

Hi Mark

Hope you are keeping well.

Your letter states that drawing 3519-ADC-ZZ- XX-DR-Z-0100, of the A508/Site Access Gyratory, will also be provided by dwg via email. However, I've yet to receive this and should be grateful if you would forward the drawing, to assist with our review.

Kind regards

**Martin Seldon, Spatial Planner**

National Highways | The Cube | 199 Wharfside Street | Birmingham | B1 1RN

**Tel:** +44 (0) 300 4703345 | **Mobile:** + 44 (0) 7787 321 881

**Web:** [www.nationalhighways.co.uk](http://www.nationalhighways.co.uk)

**GTN:** 0300 470 3345

For information about our engagement with the planning system please visit : <https://nationalhighways.co.uk/our-roads/planning-and-the-strategic-road-network-in-england/>

---

**From:** Mark Higgins <[Mark.Higgins@ADCInfrastructure.com](mailto:Mark.Higgins@ADCInfrastructure.com)>

**Sent:** 02 December 2024 16:14

**To:** Martin Seldon <[Martin.Seldon@nationalhighways.co.uk](mailto:Martin.Seldon@nationalhighways.co.uk)>

**Cc:** Stuart Dunhill <[Stuart.Dunhill@ADCInfrastructure.com](mailto:Stuart.Dunhill@ADCInfrastructure.com)>

**Subject:** RE: Northampton Gateway SRFI - proposed DCO amendment

Hi Martin

Thank you very much for your comments on our TA Addendum report and the LinSig modelling. We have considered the points raised and updated the LinSig models where appropriate. The attached letter details our response, and the revised model files are also attached for convenience.

Please let me know if you require anything further.

Many thanks

Mark

**Mark Higgins** MEng(Hons) MCIHT  
Associate Director

ADC Infrastructure Limited  
4<sup>th</sup> Floor, City Buildings, 34-36 Carrington Street, Nottingham NG1 7FG  
tel: 07532112800  
[Mark.Higgins@ADCInfrastructure.com](mailto:Mark.Higgins@ADCInfrastructure.com)  
[www.ADCInfrastructure.com](http://www.ADCInfrastructure.com)

---

**From:** Martin Seldon <[Martin.Seldon@nationalhighways.co.uk](mailto:Martin.Seldon@nationalhighways.co.uk)>  
**Sent:** 19 November 2024 15:06  
**To:** Mark Higgins <[Mark.Higgins@ADCInfrastructure.com](mailto:Mark.Higgins@ADCInfrastructure.com)>  
**Cc:** Stuart Dunhill <[Stuart.Dunhill@ADCInfrastructure.com](mailto:Stuart.Dunhill@ADCInfrastructure.com)>  
**Subject:** RE: Northampton Gateway SRFI - proposed DCO amendment

Hi Mark

Thank you for your email containing the updated TA Addendum and revised LinSig files.

Based on our review, we have the following comments:

**M1 Junction 15**

1. Model Structure: Please can you clarify whether Arm 3, Lane 1 should be connected to Arm 18, Lane 1, rather than from Arm 3, Lane 2? The nearside lane of this arm (Arm 3) is marked for both M1(S) and Grange Park, but the LinSig model allows only traffic into Saxon Avenue.

2. Traffic Flows: It is our understanding that, Flow Group 7 (2031 J1d Dev AM Peak) and Flow Group 8 (2031 J1d Dev PM Peak) of the old model (180221 M1 Junction 15 Mitigation with WL.lsg3x), have been copied across to the new model as Flow Group 1 (2031 background – AM) and Flow Group 2 (2031 background – PM). Please can you confirm that this is the case?

If the above flow assumption is correct, please can you explain why the new model sees the introduction of M1 North to M1 North U-turning flows in the AM and PM peaks? We note that this movement was not included in the previous revision of the model.

3. Signal Controllers:

- a. Controller 1 – North Side: Phase G has been coded into the LinSig model with a minimum green time of 5 seconds, however the controller specification document has a minimum green of 7 seconds. While this is not expected to change the model results, please can this be updated.
- b. Controller 2 – South Side: The controller specification document shows a phase delay value for Phase F, but this does not appear to have been coded into the LinSig model. Is there a reason for this?

We have also attached the signal controller information used for our review purposes for your consideration.

### **A508/ Site Access Gyratory**

Please can you provide us with a scaled drawing (preferably in CAD format) so that the geometric parameters entered in the model can be verified.

1. Traffic Flows: There seems to be an inconsistency in traffic flows on the A508 between this junction and the M1 Junction. The flow leaving or entering this roundabout on Arm A does not arrive or leave the M1 model on Arm D. These differences have been highlighted in Diagrams 7 and 8, but it is not clear why these discrepancies occur.

In the PM Peak, the model has assigned zero flow to the nearside lane of the southern circulatory (Arm 8, Lane 1). Please can you confirm this is realistic? Would no traffic use the nearside lane either by merging across or being fed from the upstream middle lane? If flows are not correctly assigned to the circulatory lanes, it could possibly affect the predicted level of queuing on adjacent approach to the roundabout. With the flow levels on the A508 Southbound approach and the length of the offside flare, it may not be appropriate to rely on the LinSig Delay Based Assignment. A certain degree of manual adjustments may be more realistic, depending on how the southbound approach offside flare is used once the initial queue clears following the start of the green period.

2. Model Structure: The northern circulatory (Arm 7), adjacent to the A508 Southbound approach, only shows a single lane. However, but Figure 7 in the “DCO Amendment” report shows it as two lanes. Is there a reason for modelling the arm in that way?

The site access arm (Arm 6) does not show the two lanes that enter the roundabout, but just a single lane (Arm 6, lane 2). Please can you explain why it has been modelled as a single lane?

The LinSig model does not include the pedestrian crossings located on the A508 Northbound exit and the left turn on the site access arm. Please can you justify the exclusion of these two crossings from the model?

3. Intergreen measurements: Although a scaled drawing has not been supplied, it appears that the intergreen value of 8 seconds on the A508 Southbound entry pedestrian crossing (Phase C) may be too low, as pedestrians have to walk across three lanes of traffic. Please can you confirm this value is correct? For our reference, are you able to supply us with the existing controller specification documents for the signalised crossings currently located at the roundabout?
4. Give Way Data: Please can you set out how the give way parameters on the A508 South (Arm 4) and Site Access (Arm 6) approaches have been determined? The A508 South approach seems to have calculated values, whilst the site access arm uses the standard values suggested by JCT. We would recommend you calculate the values for each lane and then show us in a supporting CAD file, the geometric parameters used to calculate the Slope and Intercept values that are used in the LinSig model, as the Coefficient and Maximum Flow values respectively.

Kind regards

**Martin Seldon, Spatial Planner**

National Highways | The Cube | 199 Wharfside Street | Birmingham | B1 1RN

**Tel:** +44 (0) 300 4703345 | **Mobile:** + 44 (0) 7787 321 881

Web: [www.nationalhighways.co.uk](http://www.nationalhighways.co.uk)

GTN: 0300 470 3345

For information about our engagement with the planning system please visit: : <https://nationalhighways.co.uk/our-roads/planning-and-the-strategic-road-network-in-england/>

---

**From:** Mark Higgins <[Mark.Higgins@ADCinfrastructure.com](mailto:Mark.Higgins@ADCinfrastructure.com)>

**Sent:** 01 November 2024 12:00

**To:** Martin Seldon <[Martin.Seldon@nationalhighways.co.uk](mailto:Martin.Seldon@nationalhighways.co.uk)>

**Cc:** Stuart Dunhill <[Stuart.Dunhill@ADCinfrastructure.com](mailto:Stuart.Dunhill@ADCinfrastructure.com)>

**Subject:** RE: Northampton Gateway SRFI - proposed DCO amendment

Hello Martin,

Stuart has passed your email below on to me.

I have investigated the cause of the discrepancy between the modelled flow groups presented in the Technical Note and the '2031 J1d Dev' traffic flows shown at Appendix 46 of the TA. The modelling of M1 J15 in the TA included the A45/Watering Lane junction (with Watering Lane represented by zone F), which has been stripped out of the current model. The discrepancy has been traced to the re-assignment of the Watering Lane/zone F flows across the matrices.

The error has been corrected in the LinSig model and the Technical Note revised accordingly. Hence, please find attached report **ADC3517-RP-A-v3** for your consideration. I have also attached the LinSig models for convenience.

Kind regards

Mark

**Mark Higgins** MEng(Hons) MCIHT  
Associate Director

ADC Infrastructure Limited  
4<sup>th</sup> Floor, City Buildings, 34-36 Carrington Street, Nottingham NG1 7FG  
tel: 07532112800  
[Mark.Higgins@ADCInfrastructure.com](mailto:Mark.Higgins@ADCInfrastructure.com)  
[www.ADCInfrastructure.com](http://www.ADCInfrastructure.com)

---

**From:** Martin Seldon <[Martin.Seldon@nationalhighways.co.uk](mailto:Martin.Seldon@nationalhighways.co.uk)>  
**Sent:** 31 October 2024 14:40  
**To:** Stuart Dunhill <[Stuart.Dunhill@ADCInfrastructure.com](mailto:Stuart.Dunhill@ADCInfrastructure.com)>  
**Subject:** RE: Northampton Gateway SRFI - proposed DCO amendment

Hi Stuart

Hope you are keeping well too.

Apologies for the delay in responding to you.

Having reviewed the TA Addendum, we note that the amendment is to increase the mezzanine floorspace of the development by 111,480 sqm to cater to the changes in market demand. We acknowledge that the trip rates and trip distribution remain the same as agreed earlier during the original DCO submission. However, we note that you have utilised the higher trip rates corresponding to the Swan Valley proxy site, for light vehicles corresponding to 16:00 to 17:00 hours for the PM peak.

The increase in mezzanine floorspace is expected to generate 105 and 128 two-way vehicles (which equates to 137 and 158 PCUs) during the standard AM and PM peak hours. This translates to the following increase in development trips passing through the M1 J15 and towards the A45 North, during the AM and PM peak hours respectively:

- a) M1 J15 - 122 and 140 PCUs
- b) Towards A45 north – 53 and 72 PCUs

We appreciate that you have undertaken a LinSig assessment for M1 J15, by utilising the 2031 with-development traffic flows from the original TA submission. However, we have noted some differences in flow values on the M1 north arm, when compared to the '2031 J1d Dev' flows available in Appendix 46 of the TA. Can you please check and get back to us on this? The network layout largely remains the same with a few changes noted in the physical length coded for some of the lanes; however, these are not expected to be significant enough to result in any material changes to the output. We recommend that you provide the model files for our review, along with the earlier approved LinSig model developed in 2018 (Appendix 46 of the TA). We note that the staging and phasing arrangements have been amended, to match the on-street controller function and we welcome this. We will provide a full response following the review of the model files.

Kind regards

**Martin Seldon, Spatial Planner**

National Highways | The Cube | 199 Wharfside Street | Birmingham | B1 1RN

**Tel:** +44 (0) 300 4703345 | **Mobile:** + 44 (0) 7787 321 881

**Web:** [www.nationalhighways.co.uk](http://www.nationalhighways.co.uk)

**GTN:** 0300 470 3345

For information about our engagement with the planning system please visit: : <https://nationalhighways.co.uk/our-roads/planning-and-the-strategic-road-network-in-england/>

---

**From:** Stuart Dunhill <[Stuart.Dunhill@ADCInfrastructure.com](mailto:Stuart.Dunhill@ADCInfrastructure.com)>

**Sent:** 31 October 2024 13:19

**To:** Martin Seldon <[Martin.Seldon@nationalhighways.co.uk](mailto:Martin.Seldon@nationalhighways.co.uk)>

**Subject:** RE: Northampton Gateway SRFI - proposed DCO amendment

Hi Martin,

I trust all is well.

Could you provide an update on where you are with reviewing our technical note and likely timescales for a response, please.

Many thanks

**Stuart Dunhill** BEng(Hons) PhD CEng MICE  
Director – [ADC Infrastructure Limited](#)  
mob: 07968411585

4<sup>th</sup> Floor, City Buildings, 34-36 Carrington Street, Nottingham NG1 7FG  
[Stuart.Dunhill@ADCInfrastructure.com](mailto:Stuart.Dunhill@ADCInfrastructure.com)  
[www.ADCInfrastructure.com](http://www.ADCInfrastructure.com)

---

**From:** Stuart Dunhill <[Stuart.Dunhill@ADCInfrastructure.com](mailto:Stuart.Dunhill@ADCInfrastructure.com)>  
**Sent:** 11 October 2024 12:09  
**To:** Martin Seldon <[Martin.Seldon@nationalhighways.co.uk](mailto:Martin.Seldon@nationalhighways.co.uk)>  
**Subject:** RE: Northampton Gateway SRFI - proposed DCO amendment

Hello Martin,

Thank you for the below update. I am meeting again with Segro next Friday morning (18<sup>th</sup>), and was wondering whether you're likely to be able to respond by then?

Many thanks

**Stuart Dunhill** BEng(Hons) PhD CEng MICE  
Director – [ADC Infrastructure Limited](#)  
mob: 07968411585

4<sup>th</sup> Floor, City Buildings, 34-36 Carrington Street, Nottingham NG1 7FG  
[Stuart.Dunhill@ADCInfrastructure.com](mailto:Stuart.Dunhill@ADCInfrastructure.com)  
[www.ADCInfrastructure.com](http://www.ADCInfrastructure.com)

---

**From:** Martin Seldon <[Martin.Seldon@nationalhighways.co.uk](mailto:Martin.Seldon@nationalhighways.co.uk)>  
**Sent:** 30 September 2024 16:27  
**To:** Stuart Dunhill <[Stuart.Dunhill@ADCInfrastructure.com](mailto:Stuart.Dunhill@ADCInfrastructure.com)>  
**Subject:** RE: Northampton Gateway SRFI - proposed DCO amendment

Hi Stuart

Thank you for your e-mail and hope you are keeping well too.

We'll review the report and I shall respond more fully shortly.

Kind regards

**Martin Seldon, Spatial Planner**

National Highways | The Cube | 199 Wharfside Street | Birmingham | B1 1RN

**Tel:** +44 (0) 300 4703345 | **Mobile:** + 44 (0) 7787 321 881

Web: [www.nationalhighways.co.uk](http://www.nationalhighways.co.uk)

GTN: 0300 470 3345

For information about our engagement with the planning system please visit: : <https://nationalhighways.co.uk/our-roads/planning-and-the-strategic-road-network-in-england/>

---

**From:** Stuart Dunhill <[Stuart.Dunhill@ADCInfrastructure.com](mailto:Stuart.Dunhill@ADCInfrastructure.com)>

**Sent:** Thursday, September 19, 2024 4:12 PM

**To:** Martin Seldon <[Martin.Seldon@nationalhighways.co.uk](mailto:Martin.Seldon@nationalhighways.co.uk)>

**Cc:** Kate Bedson <[Kate.Bedson@segro.com](mailto:Kate.Bedson@segro.com)>; Ian Rigby <[Ian.Rigby@segro.com](mailto:Ian.Rigby@segro.com)>; Steve Harley ([steve@oxalisplanning.co.uk](mailto:steve@oxalisplanning.co.uk)) <[steve@oxalisplanning.co.uk](mailto:steve@oxalisplanning.co.uk)>

**Subject:** Northampton Gateway SRFI - proposed DCO amendment

Hello Martin,

I trust that you are well.

Segro wish to apply for an amendment to the DCO at Northampton Gateway SRFI. The amendment is required in response to changes in market demand, as occupiers now require much greater volumes of mezzanine floor space than was previously the case. SEGRO are therefore seeking to amend the maximum amount of mezzanine floor space that is permitted under the DCO. This will safeguard the future build out of the SRFI site by ensuring that it can provide an appropriate mix of floor space and hence remain attractive to occupiers.

SEGRO are seeking to increase the amount of mezzanine floor space that can be delivered at Northampton Gateway SRFI by 1.2 million sqft (111,480 sqm). We have therefore prepared the attached report (reference **ADC3519-RP-A-v2 'SPL NG DCO Amendment'**) to assess the implications of this on the transport infrastructure.

Subject to an improvement scheme at the SRFI site access roundabout on the A508, the report concludes that the transport impacts arising of the increased mezzanine floor space would continue to be mitigated by the consented highway and transport infrastructure, and that the residual impacts are reduced to acceptable levels. Accordingly, there should be no highways objection to the proposed DCO amendment.

We would like to reach agreement with National Highways ahead of submitting the DCO amendment. Accordingly, we would welcome your review of the attached report.

I look forward to hearing from you. However, please don't hesitate to contact me, should you have any questions or require any further information.

Kind regards

**Stuart Dunhill** BEng(Hons) PhD CEng MICE  
Director – [ADC Infrastructure Limited](#)  
mob: 07968411585

4<sup>th</sup> Floor, City Buildings, 34-36 Carrington Street, Nottingham NG1 7FG  
[Stuart.Dunhill@ADCInfrastructure.com](mailto:Stuart.Dunhill@ADCInfrastructure.com)  
[www.ADCInfrastructure.com](http://www.ADCInfrastructure.com)

This email may contain information which is confidential and is intended only for use of the recipient/s named above. If you are not an intended recipient, you are hereby notified that any copying, distribution, disclosure, reliance upon or other use of the contents of this email is strictly prohibited. If you have received this email in error, please notify the sender and destroy it.

**National Highways Limited | General enquiries: 0300 123 5000 | National Traffic Operations Centre, 3 Ridgeway, Quinton Business Park, Birmingham B32 1AF | <https://nationalhighways.co.uk> | [info@nationalhighways.co.uk](mailto:info@nationalhighways.co.uk)**

*Registered in England and Wales no 9346363 | Registered Office: Bridge House, 1 Walnut Tree Close, Guildford, Surrey GU1 4LZ*

Consider the environment. Please don't print this e-mail unless you really need to.

**Appendix 7 – Air Quality and Noise impacts Technical Note (by Vanguardia)**

## Project Note

Project	SLPN DCO Non-Material Amendment
Subject	Effects of increases in road traffic on air quality & noise assessments
Project no	0066425-0820
Date	6 May 2025

Revision	Description	Issued by	Date	Approved
P04	Final	CG/SG	06/05/25	CG

## Introduction

SEGRO Logistics Park Northampton (SPLN), located to the west of Junction 15 of the M1, is a strategic rail freight interchange (SRFI) originally consented by the Secretary of State as a Nationally Significant Infrastructure Project (NSIP) in October 2019. The scheme is currently under construction. SEGRO, the developer, intend to submit an application for a non-material amendment to the development consent order (DCO) for SPLN to increase the mezzanine floorspace by approximately 1.2 million square feet.

This increase in floorspace will result in an increase in operational traffic. However, mezzanine floor space does not generate traffic at the same ratios as conventional floorspace. This is because mezzanine spaces are increasingly used to accommodate plant or other automated equipment which serves to deliver more efficient storage and processing of goods, but without requiring significant numbers of additional employees. Nor does mezzanine floor space increase the number of HGV loading bays. The principle that mezzanine floorspace does not generate traffic on a pro-rata basis with conventional floor space was accepted as part of the DCO for SPLN. The position agreed in the DCO was to account for mezzanine floor space as generating traffic at 50% of conventional floorspace<sup>1</sup>.

Following work undertaken by the project transport consultant (ADC Infrastructure), the associated increases in operational traffic are expected to be acceptable from a traffic/highways perspective, with the work having been reviewed by National Highways (NH) who confirmed that they have no objection to the proposed amendment<sup>2</sup>. At the time of writing, no response on the proposals has been received from the local highway authority, West Northamptonshire Council (WNC).

---

<sup>1</sup> *Northampton Gateway Strategic Rail Freight Interchange Transport Assessment, report reference ADC1475 TA ver 4, ADC Infrastructure Ltd, May 2018.*

<sup>2</sup> *Northampton Gateway SRFI, DCO Amendment to Increase Mezzanine Floor Space, Summary Statement on Traffic and Transport, report reference ADC3519-RP-B ver 1, ADC Infrastructure Ltd, March 2025.*

This Design Note has been prepared for the sole benefit, use and information of SEGRO for the purposes set out in the Design Note or instructions commissioning it and shall be subject to the express contract terms with SEGRO. VL assumes no liability or responsibility for any reliance placed on this Design Note by any third party. All concepts and proposals are copyright © 2006 – 2025 Vanguardia Limited. All rights reserved. Issued in commercial confidence.

This project note has been reviewed by the relevant Environmental Health Officers (EHOs) at the WNC Environmental Protection Team with respect to both air quality and noise. The WNC EHOs have confirmed that they are happy with the content and accept the findings (see appended email correspondence).

The DCO application for the scheme included an Environmental Statement (ES). Regarding amendments to a DCO, Government guidance<sup>3</sup> states that:

*“A change should be treated as material if it would require an updated Environmental Statement (from that at the time the original Development Consent Order was made) to take account of new, or materially different, likely significant effects on the environment.”*

It was noted that, in terms of the discussions that have already taken place with NH from a transport perspective, in the context of it being a DCO amendment, what has been proposed was based on reuse of the baseline data submitted with the original DCO application, i.e., that the additional operational traffic from the newly increased floorspace has been added to the previously proposed operational traffic flows, but there have been no changes in terms of the underlying non-development traffic (the baseline flows).

This note provides consideration of the effects of the increases in road traffic on the air quality (AQ) and noise assessments that were included in the ES in the context of whether the increase in mezzanine floorspace indicate new or materially different likely significant environmental effects.

## **Air Quality: Baseline conditions**

A review of the current air quality conditions within the vicinity of the Site and the areas considered as part of the original DCO approval indicates twelve key areas were considered (eight of which were areas with an AQMA at the time of the assessment).

In 2024 two of the areas closest to the application site considered within the air quality assessment works which have AQMA's within were revoked. These are:

- AQMA1 – M1
- AQMA5 - A45 Wootton

The air quality monitoring data within these revoked AQMA's and surrounding area of the Site for the last five years of available data are set out below, which demonstrate NO<sub>2</sub> annual mean concentrations are now comfortably within the annual mean objective (40 µg/m<sup>3</sup>).

---

<sup>3</sup> Department for Communities and Local Government (2015), Planning Act 2008: Guidance on Changes to Development Consent Orders

**Local NO<sub>2</sub> Monitoring Data in the Vicinity of the Site**

ID	Type	Annual Mean (µg/m <sup>3</sup> )				
		2019	2020	2021	2022	2023
13	Roadside	38.2	28.9	22.2	20.5	16.0
12	Roadside	25.8	19.4	20.2	19.7	17.7
14	Roadside	24.2	18.9	20.5	20.0	21.4
15	Roadside	29.5	24.2	19.3	17.7	17.4
95	Kerbside	-	-	-	-	16.4
96	Roadside					13.9
11	Kerbside	33.8	26.3	26.5	25.9	23.4
67	Kerbside	-	17.0	21.3	15.7	20.0
66	Kerbside	-	30.1	20.6	16.4	15.1
GPKa	Roadside	25.4	21.4	22.7	20.7	18.8
BI1	Other	-	-	-	7.9	6.6
Objective		40				

Notes: **Bold** indicates an exceedance of the NO<sub>2</sub> annual mean objective



## Air Quality: Methodology

### Traffic Screening Methodology

The Environmental Protection UK (EPUK) and Institute of Air Quality Management (IAQM), (2017) guidance document<sup>4</sup> provides the following indicative criterion for when an air quality impact assessment is required:

#### Stage 1 – Criteria to proceed to Stage 2:

- If any of the following apply to the proposed development:
  - Contains 10 or more residential units or a site area of more than 0.5ha; or
  - Contains more than 1,000 m<sup>2</sup> of floor space for all other uses or a site area greater than 1ha.
- Coupled with any of the following:
  - The development has more than 10 parking spaces; or
  - The development will have a centralised energy facility or other centralised combustion process.

#### Stage 2 – Indicative criteria to proceed to an impact assessment:

- A change of cars / LDVs (light duty vehicles) flow of:
  - More than 100 AADT within or adjacent to an AQMA; or
  - More than 500 AADT elsewhere.
- A change of HDVs (heavy duty vehicles) flow of:
  - More than 25 AADT within or adjacent to an AQMA; or
  - More than 100 AADT elsewhere.

The uplift in traffic associated with the DCO amendment, as provided by ADC, is set out below:

additional traffic due to increased mezzanine floor space - daily (total vehicles)					
	A45	M1 south	A508 (btw site and M1 J15)	M1 north	A508 south of site
arrival	310	191	693	191	113
departure	381	170	701	149	95
<b>two-way</b>	<b>691</b>	<b>362</b>	<b>1394</b>	<b>341</b>	<b>207</b>
of which HGV (vehicles)					
	A45	M1 south	A508 (btw site and M1 J15)	M1 north	A508 south of site
arrival	66	53	167	48	15
departure	72	58	182	52	0
<b>two-way</b>	<b>138</b>	<b>111</b>	<b>349</b>	<b>100</b>	<b>15</b>

<sup>4</sup> Environmental Protection UK (EPUK) and Institute of Air Quality Management (IAQM), 2017. Land-use Planning & Development Control: Planning for Air Quality

As the proposals are for more than 1,000 m<sup>2</sup> and assumed changes to parking levels will include provision for more than 10 new parking spaces, it is anticipated that Stage 1 of the guidance is exceeded. A screening of the uplift in traffic in isolation (set out above) of the DCO amendment would exceed Stage 2 and trigger the need for an impact assessment.

### **Baseline Position for Assessment**

Given that the site is already under construction pursuant to the extant DCO consent, it is reasonable to assume that the previously assessed operational impacts of the DCO permission will occur, and therefore, only the uplift in traffic associated with the DCO amendment need to be considered.

The following scenarios were considered for the approved DCO scheme:

- Model verification – the most recent relevant monitoring data, at the time of writing, for each study area;
- 2018 baseline year;
- 2021 (opening year), without development (B1);
- 2021 (opening year), with development (H1);
- 2031 (assumed full operation year), without development (D1);
- 2031 (assumed full operation year), with development (J1d); and
- 2031 (assumed full operation year), with development and proposed 'Rail Central' development (J3).

In respect to the above scenarios, it is noted that assumptions used for the 2021 'Do Something' scenario was based on the Roade Bypass not yet being operational, but the 2031 'Do Something' did assume the bypass would be in place. This bypass is now open and operational. On this basis, the 2021 'Do Something' scenario is now deemed obsolete. Furthermore, the 2031 'Do Something' with the 'Rail Central' is deemed obsolete on the basis that the Rail Central project has been withdrawn.

Based upon the above, the *2031 (assumed full operation year), with development (J1d)* would be deemed as the future baseline position.

An Air Quality Modelling Assessment of the uplift in traffic is appended to this note.

### **Air Quality: Modelling Assessment summary**

Based upon the Air Quality Modelling Assessment and improved baseline air quality concentrations in the vicinity of the Site, it is not anticipated that the increase in traffic will result in any new, or materially different, likely significant effects on the environment with respect to air quality.

### **Noise: baseline conditions**

When considering the potential noise effects of the proposed increase the mezzanine floorspace, it is considered reasonable to take the same approach as has been used for transport, i.e., to use the same baseline data as was submitted with the original DCO application, both in terms of road traffic flows when considering road traffic noise, and noise survey measurements when considering on-site operational noise.

## Noise: road traffic

### Original road traffic noise assessment

The assessment of road traffic noise as included in the original DCO application was based on comparisons of predicted noise levels using two sets of traffic scenarios:

- The change between the future baseline (do-minimum, DM) and the future with development (do-something, DS) scenarios for the year **2021**, which represented the expected opening year of SLPN at that time (pre-COVID) and did not include the Roade Bypass or some of the highway works; and
- The change between the DM and DS scenarios for the year **2031**, with SLPN being fully operational and included all highway works and the Roade Bypass. Note that, as discussed above, an additional 2031 DS scenario was produced that included traffic from the proposed Rail Central development; however, as that project has been withdrawn, this scenario is deemed obsolete.

For the assessment of road traffic noise, significant effects on the environment at receptors were identified when two thresholds were triggered (i.e., concurrently):

1. The change in noise level between the DM and DS scenarios for a given year was an increase of 1.0 dB or more; and
2. The absolute noise level for the DS scenario exceeded a specific threshold, termed the Significant Observed Adverse Effect Level (SOAEL).

### Assessment of additional traffic: road traffic noise

The increases in operational traffic provided by ADC (see AQ section above) are based on the SRFI being fully operational, and therefore relevant to the 2031 scenarios from the original assessment. The 2031 scenarios represent the maximum amount of traffic the development is predicted to generate and therefore a worst-case in terms of potential noise impacts.

Using this data, basic noise level (BNL) calculations of road traffic noise in accordance with CRTN<sup>5</sup> have been undertaken by adding on the additional traffic to the corresponding links from the original 2031 DS dataset and compared to the results to BNL calculations undertaken using the 2031 DM dataset:

- The results indicate that some of the impacts (i.e., the increases between the DM and DS scenarios) increase by 0.1 dB compared to the DCO submission (on the A508 between the Main Site and Junction 15 of the M1, the M1 NB (dep) and the A45);
- In the original DCO submission, road traffic noise was modelled at specific receptors, which were typically the closest sensitive properties to the roads. Considering the receptors adjacent to the roads for which additional data has been provided by ADC, i.e., those expected to be most affected by the changes, if any of the impacts were increased by 0.1 dB, no significant adverse effects on the environment would be indicated – the worst-case would be for the Hilton Hotel which would change from a 0.7 dB increase to a 0.8 dB increase during the daytime when including the additional traffic. This would not indicate a significant adverse effect on the environment.

---

<sup>5</sup> Department of Transport Welsh Office (1988), *Calculation of Road Traffic Noise*

Therefore, no additional increases in road traffic noise of at least 1.0 dB are predicted, and no changes to the predicted effects are indicated with the inclusion of the additional traffic when compared with the results of the original DCO assessment, i.e., there are no new, or materially different, likely significant effects on the environment.

## **Noise: operational (on-site)**

### **Original operational noise assessment**

The assessment of operational noise as included in the original DCO application was based on a comparison of predicted noise from activities taking place on-site, assuming it was fully operational, and the existing background noise level at each receptor, using the principles of the British Standard BS 4142<sup>6</sup>. The existing noise levels used in the assessment were derived from the results of a baseline noise survey undertaken in late 2016 and mid-2017, before construction of the development began.

For the assessment of operational noise, an initial estimate of impact was identified by subtracting the existing background sound level from the predicted noise level; the greater the difference, the greater the magnitude of the initial impact estimate, based on the following:

- A difference of around +10 dB or more is likely to be an indication of a significant adverse impact, depending on the context;
- A difference of around +5 dB is likely to be an indication of an adverse impact, depending on the context;
- Where the rating level does not exceed the background sound level, this is an indication of the specific sound source having a low impact, depending on the context; and
- The lower the rating level is relative to the measured background sound level, the less likely it is that the specific sound source will have an adverse impact.

If necessary, the absolute level of predicted operational noise was then compared to guideline values to provide additional context.

Operational noise predictions were based on HGV service yard operations (manoeuvres and loading/unloading), both HGVs and light vehicles travelling on the internal access roads, as well as rail terminal activity (e.g., reach stackers, freight trains, gantry cranes etc). The number of sources were based on the one-hour periods with the highest levels of activity during both the day and night. The noise was predicted at each receptor using the 3D model.

It should be noted that the proposed increase in mezzanine floorspace would not result in any additional rail activity, as the assumptions used for the operational noise assessment as originally submitted were based on the terminal operating at full capacity and that capacity remains unchanged.

### **Assessment of additional traffic: operational noise**

ADC have advised on the increase in operational traffic and that increase has been proportionality applied to the modelled results from the original DCO assessment for the HGVs and light vehicles travelling on the internal

---

<sup>6</sup> BS 4142:2014: *Methods for rating and assessing industrial and commercial sound*, BSI (2014)

access roads and the HGV service yard activities within the SRFI; the other noise sources, including those associated with the rail terminal, rapid rail freight facility, aggregates yard and rail line remaining unchanged.

The results indicate that the predicted on-site operational noise levels would increase by 1 dB at some receptors when compared with the results from the original DCO assessment, primarily at those to the east of the Main Site including on Collingtree Court and Watering Lane. However, the newly predicted noise levels remain significantly below the existing measured noise levels at these locations (at least 12 dB below), which are dominated by road traffic noise from the M1. Therefore, based on the initial estimate of impact descriptions stated above, the impacts of on-site operational noise remain low, no consideration of additional context is required, and the predicted effects are unchanged compared to those stated in the original DCO assessment, i.e., there are no new, or materially different, likely significant effects on the environment.

### **Noise: assessment summary**

Based on the increases in traffic as advised by ADC, minimal increases in road traffic noise and operational noise associated with SLPN are predicted. No changes in the noise effects as predicted in the DCO submission are expected, i.e., there are no new, or materially different, likely significant effects on the environment. On this basis, the changes would be considered non-material with respect of noise.

## **APPENDIX A:**

# **CORRESPONDANCE WITH WEST NORTHAMPTONSHIRE COUNCIL ENVIRONMENTAL PROTECTION TEAM**

## Chris Goff

---

**From:** Gavin Smith <Gavin.Smith@westnorthants.gov.uk>  
**Sent:** 30 April 2025 07:15  
**To:** Simon Grubb; Chris Goff  
**Subject:** FW: SEGRO Logistics Park Northampton: proposed non-material amendment to DCO (AQ and noise)  
**Attachments:** 0066425-EN-PN001 J15 DCO Amendment 250409.pdf; 0066425-VAN-XX-XX-RP-YA-0001 Draft\_Junction\_15\_DRAFT.pdf  
**Importance:** High

**\*\*External Email. This email originated from outside Vanguardia.\*\***

Good morning Simon / Chris,

We have had an opportunity to review the content of the AQA and Project Note and can advise we are happy with the content and accept the findings.

Kind regards

**Gavin Smith**  
**Senior Environmental Health Officer**  
**Environmental Protection Team (Northampton Area)**  
**Regulatory Services**

**Upcoming Leave – 1<sup>st</sup> May to 6<sup>th</sup> May 2025.**

I work flexibly. If you receive this email outside of your own working hours, please be reassured that I do not expect an immediate response. I look forward to hearing from you during your normal working hours.

West Northamptonshire Council | The Guildhall | St Giles Square | Northampton | NN1 1DE  
Mob: 07956 075062 | [www.westnorthants.gov.uk](http://www.westnorthants.gov.uk)  
Follow us on Facebook & Twitter @westnorthants



[www.westnorthants.gov.uk](http://www.westnorthants.gov.uk)  
0300 126 7000

**Trust | High Performance | Respect | Innovate | Value | Empower**



**NEED ADVICE ON COST OF LIVING SUPPORT? THERE ARE PEOPLE ON HAND TO SUPPORT AND ADVISE YOU, SO PLEASE GET IN TOUCH TODAY.**

[www.westnorthants.gov.uk/cost-of-living](http://www.westnorthants.gov.uk/cost-of-living)

---

**From:** Chris Goff <chris.goff@vanguardia.co.uk>  
**Sent:** Thursday, April 10, 2025 8:41 AM  
**To:** Gavin Smith <Gavin.Smith@westnorthants.gov.uk>; Julie Ewers <Julie.Ewers@westnorthants.gov.uk>

**Cc:** Simon Grubb (simon@airandacoustics.co.uk) <simon@airandacoustics.co.uk>  
**Subject:** SEGRO Logistics Park Northampton: proposed non-material amendment to DCO (AQ and noise)  
**Importance:** High

Dear Gavin, Julie,

I hope this email finds you both well.

We have been commissioned by SEGRO to undertake a review of the implications in terms of air quality and noise related to proposed changes to the DCO approval at SEGRO Logistics Park Northampton (SLPN), adjacent to Junction 15 of the M1. The scheme was originally granted consent by the Secretary of State in late 2019 (for more information, see the following website: <https://national-infrastructure-consenting.planninginspectorate.gov.uk/projects/TR050006>).

SEGRO are seeking a non-material amendment to the DCO to allow for an additional ~1.2 million square feet of mezzanine floorspace.

Accordingly, we have set out within the attached Technical Note and accompanying appendix the potential impacts of the proposal on both air quality and noise.

Ahead of formal submission to the Planning Inspectorate, we would very much appreciate your review and any initial feedback on the attached documents (note that noise is discussed only in the Technical Note; the second report relates to AQ only). Our aim is to address any potential issues early on to help avoid delays further down the line.

If possible, could we kindly request your comments by close of play on 15th April 2025?

Please do let us know if you have any questions or would like to discuss the contents in more detail.

Thanks for your help on this.

Kind regards,

Simon Grubb (AQ) and Chris Goff (noise)

Chris Goff  
Associate  
Vanguardia | Acoustics  
T: +44 (0)1883 718690  
M: +44 (0)7935 601214  
E: [chris.goff@vanguardia.co.uk](mailto:chris.goff@vanguardia.co.uk)  
[www.vanguardia.co.uk](http://www.vanguardia.co.uk) | [LinkedIn](#) | [Twitter](#) | [Instagram](#)

*Please note that I do not work on Fridays.*

---

**VANGUARDIA**

---

A BURO HAPPOLD COMPANY

This transmission is confidential and intended solely for the person or organisation to whom it is correctly addressed. If you are not the intended recipient of this transmission, you should not take any action in reliance on it. Further, this transmission may contain confidential design and other information owned by Vanguardia Limited. You should not copy, distribute, use, offer for sale or hire such information or in any way infringe the design and intellectual property rights of Vanguardia Limited. It is intended that communication by email from Vanguardia Limited or its employees is limited to communications connected to the services provided by Vanguardia Limited. Vanguardia Limited accepts no liability for any communications not connected to the services it provides. Computer viruses may be transmitted or downloaded onto your computer system via email communication. It is the recipient's responsibility to take any action necessary to prevent computer viruses being transmitted in this way. Accordingly, Vanguardia Limited disclaims all responsibility which arises directly or indirectly from such transmission of computer viruses. Vanguardia Limited. Registered in England: 05666276.

---

Any views expressed in this email are those of the individual sender and are not necessarily those of West Northamptonshire Council unless explicitly stated.

This email (including any attachments) may contain confidential or privileged information and is intended solely for the use of the individual or entity to whom it is addressed. Any confidential, sensitive or protectively marked material must be handled accordingly.

If you are not the intended recipient you must not disclose, distribute, copy, print or rely on any of the information contained in the email or attachments, and all copies must be deleted immediately. If you do receive this email in error, please notify the sender immediately and note that confidentiality or privilege is not waived or lost.

West Northamptonshire Council may monitor the contents of emails sent and received via its network for the purposes of ensuring compliance with relevant legislation and the Council's policies and procedures. All such monitoring will take place in accordance with relevant legislation including privacy and data protection legislation. For details of how West Northamptonshire Council uses personal information please see the Council's website.

West Northamptonshire Council has scanned this email and attachments for viruses but does not accept any responsibilities for viruses once this email has been transmitted. You should therefore carry out your own anti-virus checks before opening any documents.

---

## **APPENDIX B:**

# **AIR QUALITY MODELLING REPORT**

---

**VANGUARDIA**

---

A BURO HAPPOLD COMPANY

# **SEGRO Logistics Park Northampton**

## **Air Quality Modelling Assessment**

**0063244-VAN-XX-XX-RP-YA-0001**

**0063244**

00

6 May 2025

Revision P00

Revision	Description	Issued by	Date	Checked

**Report Disclaimer**

This Report was prepared by Vanguardia Limited ("VL") for the sole benefit, use and information of Segro for consideration of the air quality impact of sports pitches at the site in Belhus Park. VL assumes no liability or responsibility for any reliance placed on this Report by any third party for any actions taken by any third party in reliance of the information contained herein. VL’s responsibility regarding the contents of the Report shall be limited to the purpose for which the Report was produced and shall be subject to the express contract terms with Segro. The Report shall not be construed as investment or financial advice. The findings of this Report are based on the available information as set out in this Report.

author                    **Simon Grubb**

date                      **06/05/2025**

approved                **Simon Grubb**

signature                

date                      **06/05/2025**

## **Contents**

<b>1</b>	<b>Introduction</b>	<b>5</b>
<b>2</b>	<b>Traffic Screening Assessment</b>	<b>6</b>
2.1	Study Areas	6
2.2	Operational Phase – Traffic (Human Receptors) Screening Criteria	7
<b>3</b>	<b>Modelling Parameters</b>	<b>12</b>
3.2	Significance Criteria	17
3.3	Assessment Uncertainty	18
<b>4</b>	<b>Operational Impacts</b>	<b>20</b>
4.1	Traffic Impacts –Human Receptors	20
<b>5</b>	<b>Mitigation Measures</b>	<b>22</b>
5.1	Operational	22
<b>6</b>	<b>Summary &amp; Conclusions</b>	<b>23</b>
6.1	Operational Phase – Traffic Emissions	23
	<b>Appendix A – Receptor Locations</b>	
	<b>Appendix B – Traffic Data</b>	
	<b>Appendix C – Background Calibration Process</b>	
	<b>Appendix D – Verification</b>	
	<b>Appendix E – Human Receptor Impacts</b>	
	<b><u>Table of Figures</u></b>	
	<b>Figure 1 – Modelled Receptor Locations (A45 and M1)</b>	<b>12</b>
	<b>Figure 2 – Modelled Receptor Locations (Hartwell)</b>	<b>13</b>
	<b>Figure 3 – Standard Diurnal Profile</b>	<b>15</b>
	<b><u>Table of Tables</u></b>	
	<b>Table 1- Additional Development Traffic</b>	<b>8</b>
	<b>Table 2- Background Concentrations</b>	<b>15</b>

Table 3- Air Quality Impact Descriptors for Individual Human Receptors

# 1 Introduction

SEGRO Logistics Park Northampton (SPLN), located to the west of Junction 15 of the M1, is a strategic rail freight interchange (SRFI) originally consented by the Secretary of State as a Nationally Significant Infrastructure Project (NSIP) in October 2019. The scheme is currently under construction. SEGRO, the developer, intend to submit an application for a non-material amendment to the development consent order (DCO) for SPLN to increase the mezzanine floorspace by approximately 1.2 million square feet.

This increase in floorspace will result in an increase in operational traffic. However, mezzanine floor space does not generate traffic at the same ratios as conventional floorspace. This is because mezzanine spaces are increasingly used to accommodate plant or other automated equipment which serves to deliver more efficient storage and processing of goods, but without requiring significant numbers of additional employees. Nor does mezzanine floor space increase the number of HGV loading bays. The principle that mezzanine floorspace does not generate traffic on a pro-rata basis with conventional floor space was accepted as part of the DCO for SPLN. The position agreed in the DCO was to account for mezzanine floor space as generating traffic at 50% of conventional floorspace<sup>1</sup>.

Following work undertaken by the project transport consultant (ADC Infrastructure), the associated increases in operational traffic are expected to be acceptable from a traffic/highways perspective, with the work having been reviewed by National Highways (NH) who confirmed that they have no objection to the proposed amendment<sup>2</sup>. At the time of writing, no response on the proposals has been received from the local highway authority, West Northamptonshire Council (WNC).

Due to the uplift in Annual Average Daily Traffic (AADT) an Air Quality Modelling Assessment has been undertaken to indicate new or materially different likely significant environmental effects.

---

<sup>1</sup> *Northampton Gateway Strategic Rail Freight Interchange Transport Assessment, report reference ADC1475 TA ver 4, ADC Infrastructure Ltd, May 2018.*

<sup>2</sup> *Northampton Gateway SRFI, DCO Amendment to Increase Mezzanine Floor Space, Summary Statement on Traffic and Transport, report reference ADC3519-RP-B ver 1, ADC Infrastructure Ltd, March 2025.*

## 2 Traffic Screening Assessment

### 2.1 Study Areas

The air quality impact assessment study areas for the original DCO application included twelve areas (of which at that time, eight were areas within an AQMA, as set out below):

- AQMA 1: M1
- AQMA 2: Victoria Promenade (City Centre)
- AQMA 3: St James/Weedon Rd (City Centre)
- AQMA 4: Kingsthorpe Grove/Harborough Rd (City Centre)
- AQMA 5: A45 Wootton
- AQMA 6: Campbell Square/Grafton Street (City Centre)
- AQMA 8: St Michael's Road (City Centre)
- Towcester AQMA

In 2024 two of the areas closest to the application site considered within the air quality assessment works which have AQMA's within were revoked. These are:

- AQMA1 – M1
- AQMA5 - A45 Wootton

The other four areas which were considered within the original DCO application were:

- Blisworth & Milton Malsor
- Hartwell
- Grafton Regis & Pottersbury
- Roade & West Lodge Cottages

For completeness these areas have been reconsidered as part of this Air Quality Modelling Assessment.

## 2.2 Operational Phase – Traffic (Human Receptors) Screening Criteria

The key guidance document which has been used to determine the potential for impacts upon air quality is the Environmental Protection UK (EPUK) & Institute of Air Quality Management (IAQM) (2017)<sup>3</sup> *Land-Use Planning and Development Control: Planning for Air Quality* document.

This guidance document provides indicative screening criteria for when an Air Quality Impact Assessment is required. The following screening criteria has been considered for this AQA:

### Local Highway Network

#### Stage 1

- If any of the following apply to the proposed development:
  - Contains 10 or more residential units or a site area of more than 0.5ha; or
  - Contains more than 1,000 m<sup>2</sup> of floor space for all other uses or a site area greater than 1ha.
- Coupled with any of the following:
  - The development has more than 10 parking spaces; or
  - The development will have a centralised energy facility or other centralised combustion process.

#### Stage 2

- A change of LDV, (light duty vehicle) flow of:
  - More than 100 AADT (Annual Average Daily Traffic) within or adjacent to an Air Quality Management Area (AQMA); or
  - More than 500 AADT elsewhere.
- A change of HDV, (heavy duty vehicle) flow of:
  - More than 25 AADT within or adjacent to an AQMA; or
  - More than 100 AADT elsewhere.

The proposals will see more than 1,000 m<sup>2</sup> developed for commercial use and associated car parking spaces created, therefore the EPUK & IAQM (2017) Stage 1 criteria is exceeded. Consequently, the proposals have been screened against the EPUK & IAQM (2017) Stage 2 criteria.

As set out in **Table 1**, the transport consultants ADC Infrastructure Ltd provided the uplift in development daily vehicular trip generation predictions for the local road network in AADT. This table sets out the uplift in traffic associated with the DCO amendment.

---

<sup>3</sup> Environmental Protection UK (EPUK) and Institute of Air Quality Management (IAQM), 2017. *Land-use Planning & Development Control: Planning for Air Quality*.

**Table 1- Additional Development Traffic**

Link ID	Total AADT Flows	Total AADT HGVs Flows	Located in/close to an AQMA?
<b>Previous AQMA 1: M1</b>			
15	191	48	No
16	149	52	No
<b>AQMA 3: St James/Weedon Rd (City Centre)</b>			
370 & 378	0	0	Yes
364 & 369	0	0	Yes
364 & 369 J	0	0	Yes
379 & 381	0	0	Yes
371 & 380	0	0	Yes
360 & 377	0	0	Yes
368 & 384	0	0	Yes
358 & 366	0	0	Yes
365 & 376	0	0	Yes
354 & 375	0	0	Yes
374 & 382	0	0	Yes
<b>AQMA 4: Kingsthorpe Grove/Harborough Rd (City Centre)</b>			
432 & 446	5	4	Yes
421 & 425	15	1	Yes
418 & 437	0	0	Yes
422 & 431	0	0	Yes
430 & 447	0	0	Yes
423 & 427	0	0	Yes
419 & 442	24	7	Yes
439 & 443	24	7	Yes
426 & 445	15	1	Yes
428 & 434 J	15	1	Yes
428 & 434	15	1	Yes
<b>Previous AQMA 5: A45 Wootton</b>			
37	331	72	No
38	279	66	No
39	362	72	No
40	276	66	No

<b>AQMA 2: Victoria Promenade (City Centre), AQMA 6: Campbell Square/Grafton Street (City Centre), and AQMA 8: St Michael's Road (City Centre)</b>			
398 & 399	4	4	Yes
272	65	9	Yes
290 & 291	0	0	Yes
394	32	3	Yes
394 J	32	3	Yes
386 & 395	4	4	Yes
289	32	3	Yes
387	32	3	Yes
407	0	0	Yes
407 J	0	0	Yes
414 & 417	0	0	Yes
413 & 415	0	0	Yes
408 & 410	35	10	Yes
414 & 417J	0	0	Yes
409 & 412	35	10	Yes
411 & 416	35	10	Yes
<b>Towcester AQMA</b>			
45 & 46	0	0	Yes
<b>Blisworth &amp; Milton Malsor</b>			
19	15	-	No
19J	15	-	No
20	0	-	No
20J	0	-	No
21	0	0	No
22	0	0	No
23	0	0	No
24	0	0	No
25	0	0	No
26	0	-	No
27	15	0	No
28	0	0	No
29	0	0	No

29J	0	0	No
30	0	0	No
30J	0	0	No
31	15	0	No
32	0	-	No
13	33	8	No
14	30	11	No
<b>Hartwell</b>			
17	170	58	No
18	191	53	No
<b>Grafton Regis &amp; Pottersbury</b>			
176 & 177	41	15	No
348 &c351	0	0	No
<b>Roads &amp; West Lodge Cottages</b>			
1 & 2	15	0	No
3 & 4	0	0	No
3 & 4J	0	0	No
11 & 12	0	-	No
11 & 12J	0	-	No
9 & 10	33	0	No
7 & 8	33	0	No
5 & 6	0	0	No
111 & 112	208	15	No
55&56	153	15	No
57&58	139	15	No
57&57 R	140	15	No

The daily vehicular trip generation predictions in **Table 1** indicates that for roads which are not located within an AQMA, the proposed increase in floorspace would not result in greater than 500 AADT (total vehicles) or 100 AADT (HGVs) at most of the previously modelled areas. The exceptions are set out below.

For the "Previous AQMA 1: M1", since Links 15 and 16 run adjacent to each other (the northbound and southbound carriageway of the M1), the uplift exceeds the screening criteria for HGVs, and therefore an updated modelling assessment, accounting for the uplift of vehicular trips at this location should be undertaken.

For the "Previous AQMA 5: A45 Wootton", since, as above, certain links run adjacent to each other, the uplift exceeds the screening criteria for both HGVs and all vehicles, and therefore an updated modelling assessment, accounting for the uplift of vehicular trips at this location should be undertaken.

For "Hartwell", since, as above, Links 17 and 18 run adjacent to each other, the uplift exceeds the screening criteria for HGVs, and therefore an updated modelling assessment, accounting for the uplift of vehicular trips at this location should be undertaken.

### 3 Modelling Parameters

#### 3.1.1 Sensitive Human Receptors

The concentrations of NO<sub>2</sub>, PM<sub>10</sub>, and PM<sub>2.5</sub> have been considered as part of this Air Quality Modelling Assessment.

For consistency the same modelled receptor locations (where modelling was required) have been considered, as per the original DCO approval. These modelled human receptor locations are outlined in **Appendix A** and illustrated in Figure 1 and **Figure 2**.



Figure 1 – Modelled Receptor Locations (A45 and M1)



**Figure 2 – Modelled Receptor Locations (Hartwell)**

### 3.1.2 Assessment Scenarios

The following scenarios have been considered for this Air Quality Modelling Assessment:

- 2023 verification;
- 2031 (assumed full operation year), with development (scenario J1d from the strategic transport model); and
- 2031 (assumed full operation year), with development (scenario J1d from the strategic transport model) + proposed DCO Amendments

The traffic data used for the model verification process has been taken from Department for Transport (DfT) point counts<sup>4</sup> in the area.

The traffic data is set out in full in **Appendix B**.

### 3.1.3 Modelling Methodology

#### 3.1.3.1 Dispersion Model

<sup>4</sup> Department for Transport. *Road Traffic Statistics*. <https://roadtraffic.dft.gov.uk/>

The modelling of the release of vehicular emissions, (dispersion), into the air has been carried out using the latest version of the air dispersion model: Atmospheric Dispersion Modelling System for Roads (ADMS-Roads) v5.0.1.3. The model calculates pollution concentrations and deposition over a specified area and/or at a specified location, based upon the following input information:

- Source parameters: e.g. highway width, average speed of vehicles, the number of vehicles per hour and the diurnal traffic profile;
- Meteorological parameters: e.g. wind speed, direction, precipitation, temperature, and atmospheric stability; and
- Topographical factors: e.g. ground levels, terrain, buildings, gradients and surface roughness.

The following information, as set out in DEFRA (2022) LAQM Technical Guidance TG(22)<sup>5</sup> has been utilised within this AQA:

*“For junctions, common sense, driving experience and local knowledge are helpful to estimate speeds. For example, for a section of road leading up to traffic lights, the aim should be to estimate average speeds over a 50 m section of road:*

- *Traffic pulling away from the lights, e.g. 40-50kph;*
- *Traffic approaching the lights when green, e.g. 20-50kph; and*
- *Traffic on the carriageway approaching the lights when red, e.g. 5-20kph, depending on the time of day and how congested the junction is.*

*It is considered that the combined effect of these three conditions is likely in most instances to be a two-way average speed for all vehicles of 20 to 40kph. Speeds in similar ranges would also apply at roundabouts, although on sections of large roundabouts, speeds may well average between 40-50kph.”*

### 3.1.3.2 Meteorological Data

The meteorological data required for the ADMS model must be sourced from a representative location to the study site and include a full year of sequential readings. A review of the nearest available meteorological stations indicates Bedford is the most suitable site with the most complete/representative information. 2023 meteorological data has been utilised for this assessment in line with the verification year.

It is recognised that a minimum data capture of 90% is recommended for representing hourly dispersion conditions within the dispersion model. Missing lines of meteorological data can be interpolated or filled by data for these specific hours from a neighbouring site. The data capture for Bedford in 2023 was within an acceptable margin error for use.

---

<sup>5</sup> Department for Environment, Food & Rural Affairs, 2022. Local Air Quality Management. Technical Guidance (TG22).

### 3.1.3.3 Diurnal Profile

A standard diurnal profile from the Department of Transport website<sup>6</sup> has been utilised as part of the modelling process for an average 7-day week in 2023. The diurnal profile is illustrated in **Figure 3**.

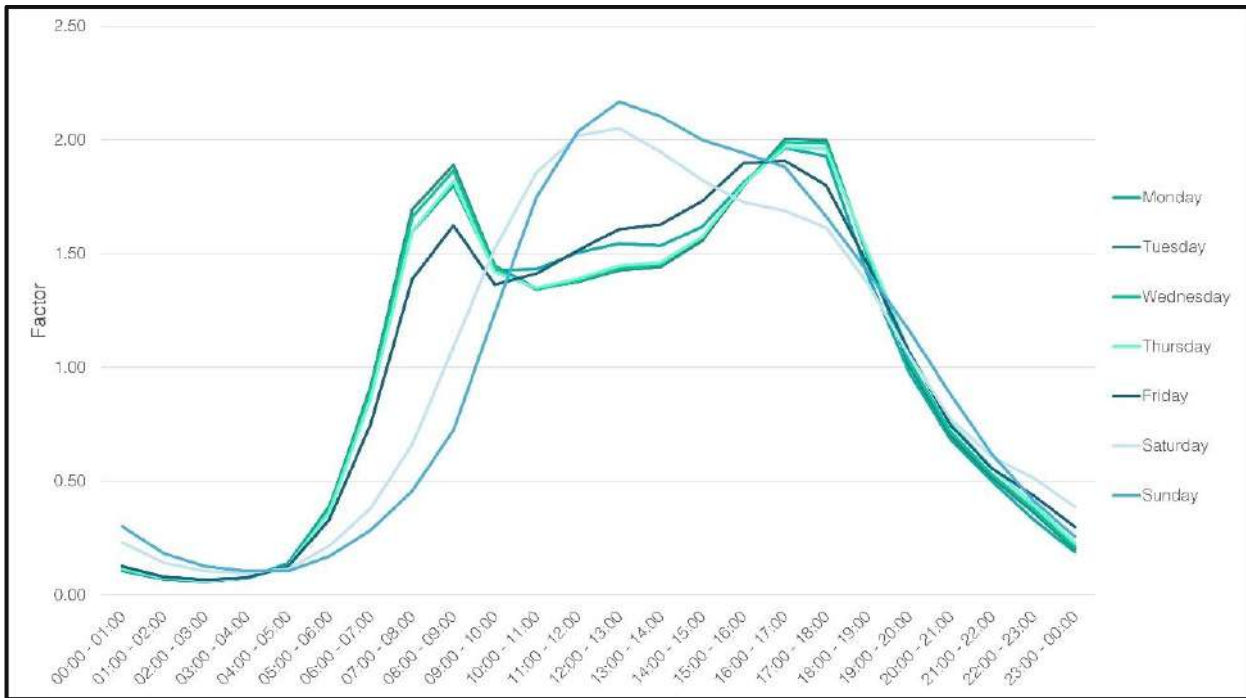

**Figure 3 – Standard Diurnal Profile**

### 3.1.3.4 Background Concentrations

The DEFRA website includes estimated background air pollution data for NO<sub>x</sub>, NO<sub>2</sub>, PM<sub>10</sub>, and PM<sub>2.5</sub> for each 1km by 1km OS grid square<sup>7</sup>. Background pollutant concentrations are modelled from the base year of 2021 and based on ambient monitoring, meteorological data from 2023 and then projected for future years. **Table 2** sets out the calibrated background concentrations used to inform the AQA. The background calibration process for WNC is set out in **Appendix C**.

**Table 2- Background Concentrations**

Pollutant	2023	2025	2031
NO <sub>2</sub>	7.3 – 10.3	8.2	6.2 – 7.5
PM <sub>10</sub>	13.6 – 14.3	12.2	13.0 – 14.2
PM <sub>2.5</sub>	6.7 – 7.2	6.5	6.2 – 6.9

<sup>6</sup> Department of Transport Table TRA0307: <https://www.gov.uk/government/collections/road-traffic-statistics>

<sup>7</sup> Department for Environmental Food and Rural Affairs. Accessible at: <https://uk-air.defra.gov.uk/data/laqm-background-maps?year=2021>

### 3.1.3.5 Emission Factors

There are numerous sources of NO<sub>2</sub>, PM<sub>10</sub> and PM<sub>2.5</sub> which include for example, industry and domestic origins. However, the main source is usually road transport. For the purpose of this Air Quality Modelling Assessment and due to the absence of other sources in the area, only road traffic emissions have been modelled. Emission factors have been calculated using the DEFRA Emission Factor Toolkit v13.

It has been widely known for some time that NO<sub>x</sub>/NO<sub>2</sub> levels historically have not been reducing as quickly as anticipated, and this was identified by DEFRA in 2011. This was recently reiterated in an IAQM Interim Position Statement (v1.1)<sup>8</sup> released in July 2018 recognising that emissions from diesel vehicles have not declined as expected by DEFRA. This document has since been formally withdrawn, stating:

*“There is a growing body of evidence to suggest that the latest COPERT vehicle emission factors, which feed into the EFT (v9 and onwards), reflect the real-world NO<sub>x</sub> emissions more accurately.*

*It is judged that an exclusively vehicle emissions-based sensitivity test is no longer necessary.*

*On this basis, the EFT may be used for future year modelling with greater confidence when considering the per vehicle emission, provided that the assessment is verified against measurements made in the year 2016 or later.”*

Therefore, the EFT v13 is acceptable for an assessment year of 2023 (verification) and 2031 (assessment year) and no sensitivity test has therefore been undertaken.

Vehicles emit NO<sub>x</sub> with different proportions of NO<sub>2</sub>. Following release into the atmosphere, chemical reactions take place between nitric oxide (NO), NO<sub>2</sub> and Ozone (O<sub>3</sub>). In this AQA, the modelling of NO<sub>x</sub> emissions has taken place and the resulting NO<sub>2</sub> concentration has been calculated post modelling using the DEFRA NO<sub>x</sub> to NO<sub>2</sub> Calculator (v9.1)<sup>9</sup>.

### 3.1.3.6 Model Verification

Whilst the ADMS-Roads model is widely accepted for its use in assessments of this nature, it is still important that a model verification process is undertaken to confirm that the model's performance is within an acceptable margin of error. Therefore, a comparison of modelled results with monitored results has been undertaken in line with TG22.

To note, TG22 states:

*“Local authorities are reminded that any detailed dispersion modelling, should be compared against local monitoring data in order to provide confidence in the results and any decisions made based on the outcome of the modelling. However, this should be only possible if the measurements are of good quality, have been measured over a reasonable time period, and are representative of the receptor location assessed.”*

The model verification process is set out in **Appendix D**.

Three model verifications were undertaken; in WNC. Receptor concentrations adjacent to the M1 north of Junction 15 (Collingtree) were adjusted by the factor derived at the monitoring location in this area, receptor concentrations adjacent to the A45: Wotton were adjusted by the factor derived at the monitoring locations located adjacent to this road and

---

Institute of Air Quality Management, 2018. *Dealing with Uncertainty in Vehicle NO<sub>x</sub> Emissions within Air Quality Assessments*.

<sup>9</sup> Department for Environment, Food & Rural Affairs. NO<sub>x</sub> to NO<sub>2</sub> Calculator. Accessible at: <https://laqm.defra.gov.uk/air-quality/air-quality-assessment/nox-to-no2-calculator/>

receptor locations located adjacent to the M1 south of Junction 15 (Hartwell) were adjusted by the factor derived at the monitoring location in Hartwell.

## 3.2 Significance Criteria

### 3.2.1.1 Operational Traffic (Human Receptors)

Currently there is no formal guidance on the absolute magnitude and significance criteria for the assessment of air quality impacts. However, the EPUK & IAQM (2017) document have published recommendations for describing the impact at individual receptor locations as set out in **Table 3** and utilised to determine the description of any impact.

**Table 3- Air Quality Impact Descriptors for Individual Human Receptors**

Long term average Concentration at receptor in assessment year.	% Change in concentration relative to Air Quality Action Level (AQAL*)				
	<0.5	1	2-5	6-10	>10
75% of less of AQAL	Negligible	Negligible	Negligible	Slight	Moderate
76-94% of AQAL	Negligible	Negligible	Slight	Moderate	Moderate
95-102% of AQAL	Negligible	Slight	Moderate	Moderate	Substantial
103-109% of AQAL	Negligible	Moderate	Moderate	Substantial	Substantial
110% or more of AQAL	Negligible	Moderate	Substantial	Substantial	Substantial

Notes:  
 Values are rounded to the nearest whole number.  
 When defining the concentration as a percentage of the AQAL, use the 'without scheme' concentration where there is a decrease in pollutant concentration and the 'with scheme;' concentration for an increase.  
 AQAL = Air Quality Assessment Level, which may be an air quality objective, EU limit or target value, or an Environment Agency 'Environmental Assessment Level (EAL).'

EPUK & IAQM (2017) advice provides guidance on the severity of an impact as a descriptor. However, although the impacts might be considered 'Slight,' 'Moderate' or 'Substantial' at one or more receptor location, the overall effects of a proposed development may not always be judged as being 'significant.' Consideration of the overall effect on air quality needs to incorporate consideration of impacts as a whole including the extent to which receptors represent sensitive locations and whether this wider impact is significant or not.

The EPUK & IAQM (2017) guidance goes on to state:

*"Where the air quality is such that an air quality objective at the building façade is not met, the effect on residents or occupants will be judged as significant, unless provision is made to reduce their exposure by some means."*

To note, when considering this, careful considerations has been made of the WHO guidelines. The current air quality objectives were set based on NO<sub>2</sub> in particular being a "threshold" pollutant – i.e. that there is a "safe" level of NO<sub>2</sub> in the ambient air that will not damage the health of an average person. In recent years this has been called into question, and the WHO Guidelines, while not statutory, are considerably lower (10 µg/m<sup>3</sup> compared to 40 µg/m<sup>3</sup> for NO<sub>2</sub>). While using the current objectives is not technically incorrect, there is an argument to be made that any worsening of air quality, particularly within an AQMA, should not be allowed to occur as the potential to damage health is clear.

Air Quality is now the leading environmental risk factor globally, and the issue is rising in prominence all the time. As such worsening the air quality within an existing AQMA, even by a small amount should be carefully considered.

The guidance believes that the assessment of significance should be based on professional judgement, with the overall air quality impact of the scheme / proposed development described as either significant or not significant. In drawing this conclusion, the following factors should be taken into account:

- The number of properties/receptors affected by different levels of impacts;
- The magnitude of any changes and descriptors;
- Whether a new exceedance of an objective or limit value is predicted to arise or an existing exceedance is removed, or an existing exceedance is substantially increased or reduced;
- The level of uncertainty, including the extent to which worst case assumptions have been made; and
- The extent of any exceedance of an objective or limit value.

The judgement of the significance should be made by a competent professional who is suitably qualified.

### 3.3 Assessment Uncertainty

There are many uncertainties when considering both measured and predicted pollution concentrations. The model is dependent upon the traffic data provided for the project, and should this be subject to change, so may the resulting pollution concentrations.

The background air quality concentrations have been taken from the DEFRA background mapping. The DEFRA website<sup>10</sup> includes estimated background air pollution data for NO<sub>x</sub>, NO<sub>2</sub>, PM<sub>10</sub> and PM<sub>2.5</sub> for each 1km by 1km OS grid square. Background pollutant concentrations are modelled from the base year of 2021 and based on ambient monitoring and meteorological data from 2021. The 2021 mapping includes projections for future years, up to currently 2040. Furthermore, the concentrations are modelled at a standard 'living height,' which has been averaged across the grid square.

There is discrepancy between the concentrations mapped by DEFRA and those recorded at local background sites. Therefore, a calibration factor has been derived from the ratio between monitored background concentrations (local authority monitoring) and DEFRA background mapped concentrations to improve the accuracy of the background concentrations. This is supported by TG22, which states:

*"Where a model has been used to predict background concentrations (for example based on an emissions inventory), the modelled background concentrations should also be verified and where necessary adjusted.*

*If national background maps are used, these should first be compared against any local monitoring to check they are representative of the area. In most cases there is good agreement with local monitoring, but some locations may not agree. Local authorities are not expected to verify and adjust the national background maps. Where these*

---

<sup>10</sup> Department for Environmental Food and Rural Affairs. Accessible at: <https://uk-air.defra.gov.uk/data/laqm-background-maps?year=2021>

*estimates do not agree with local monitoring, either local monitoring may be used, or local authorities may consider adjusting the background maps."*

The calibration process for WNC is set out in Table C.1 (for NO<sub>2</sub>) and Table C.2 (for PM<sub>2.5</sub>) in **Appendix C**. To note, the PM<sub>2.5</sub> calibration factor has been applied to background PM<sub>10</sub> concentrations.

In order to avoid double counting of potential source contributions already contained within the ADMS-Roads dispersion model the NO<sub>2</sub> Adjustment for NO<sub>x</sub> Sector Removal Tool<sup>11</sup> has been used, in certain grid squares. Depending on the roads modelled, 'Motorway in' was removed from each grid square where the motorway was modelled, 'Trunk A Rd In' was removed from each grid square where the trunk roads, as recommended in the DEFRA Background Maps User Guide<sup>12</sup>. It is necessary to use the NO<sub>2</sub> Adjustment for NO<sub>x</sub> Sector Removal Tool as the relationship between NO<sub>x</sub> and NO<sub>2</sub> is not linear. To note, care was taken to only remove road sources where the entirety of the road contained within the grid square was modelled.

---

<sup>11</sup> Department for Environment, Food and Rural Affairs, 2020. *NO<sub>2</sub> Adjustment for NO<sub>x</sub> Sector Removal Tool v9.1*

<sup>12</sup> Department for Environment, Food and Rural Affairs, 2020. *Background Concentration Maps User Guide*.

## 4 Operational Impacts

### 4.1 Traffic Impacts –Human Receptors

As set out in **Section 3**, the indicative screening process highlighted that a full impact assessment maybe required for the proposed increase in mezzanine floorspace, due to the marginal exceedance of the daily development trips against the Stage 2 screening criteria in the EPUK & IAQM (2017) guidance. It should be noted that the guidance does state that “*exceeding a screening criterion [...] does not automatically lead to the requirement for a Detailed Assessment. The principle underlying this guidance is that any assessment should provide enough evidence that will lead to a sound conclusion on the presence, or otherwise, of a significant effect on local air quality*”. However, to avoid any doubt in drawing any conclusions on likely significant effects on the environment with respect to air quality a modelling assessment has been undertaken for completeness.

#### 4.1.1 2031 Impact Scenario

The ‘2031 future baseline’ NO<sub>2</sub>, PM<sub>10</sub>, and PM<sub>2.5</sub> concentrations at the previously specified human receptor locations, as set out in **Appendix A** and illustrated in **Figure 1** and **Figure 2**, has been compared to the ‘2031 future baseline + proposed development’ concentrations and the results are set out in Table E.1 to Table E.9 in **Appendix E**. The tables also set out the impact descriptor in line with the EPUK & IAQM (2017) guidance, considered against the respective annual mean air quality standard and in line with the assessment matrix set out in **Table 3**.

##### 4.1.1.1 NO<sub>2</sub>

The modelled NO<sub>2</sub> concentrations in Table E.1, Table E.4 and Table E.7 in **Appendix E** show that NO<sub>2</sub> concentrations at all specified receptor locations are below the annual mean objective (40 µgm<sup>-3</sup>).

Using the matrix in **Table 3**, it can be seen that the impacts associated with the proposed development are anticipated to be **negligible (adverse)** at all the modelled receptors.

Based on the annual average mean concentration at all receptors being below 60 µgm<sup>-3</sup>, it is unlikely that any modelled receptor identified would experience an exceedance of the 1-hour mean objective, in line with paragraph 7.97 of TG22.

##### 4.1.1.2 PM<sub>10</sub>

The modelled PM<sub>10</sub> concentrations in Table E.2, Table E.5 and Table E.8 in **Appendix E** show that PM<sub>10</sub> concentrations at all specified receptor locations are below the annual mean objective (40 µgm<sup>-3</sup>).

Using the matrix in **Table 3**, it can be seen that the impacts associated with the proposed development are anticipated to be **negligible (adverse)** at all the modelled receptors.

For PM<sub>10</sub>, the following equation can be used to derive the number of days that the 24-hour mean objective (50 µgm<sup>-3</sup>) is likely to be exceeded.

$$\text{Num. 24-hour exceedances} = -18.5 + 0.00145 \times \text{annual mean}^3 + \left( \frac{206}{\text{annual mean}} \right)$$

There are limitations to this calculation, and this is set out in TG22, which states:

*“The relationship does have limitations in so far that it should not be applied when the annual mean PM<sub>10</sub> concentration is lower than 14.8 µg/m<sup>3</sup>”.*

On the basis that the majority of receptors are above 14.8 µg/m<sup>3</sup>, the formula above can be used to inform the number of 24-hour mean objective exceedances.

The highest annual mean PM<sub>10</sub> concentration is 18.7 µg/m<sup>3</sup>, predicted at C16 in 2031. Based on the formula above, this predicts 2.0 exceedance days, which is below the 35-days annual limit. It is therefore thought that none of the receptors would be exposed to any material impact from the short-term concentrations of PM<sub>10</sub>.

#### 4.1.1.3 PM<sub>2.5</sub>

The modelled PM<sub>2.5</sub> concentrations in Table E.3, Table E.6 and Table E.9 in **Appendix E** show that PM<sub>2.5</sub> concentrations at all specified receptor locations are below the Stage 2 Post 2020 annual mean limit (20 µg/m<sup>3</sup>).

Using the matrix in **Table 3**, it can be seen that the impacts are anticipated to be **negligible (adverse)** at all the modelled receptor locations.

#### 4.1.1.4 Significance of Impacts

The Impacts on the receptors associated with the proposed development are anticipated to **negligible (adverse)** for all existing modelled receptors and all concentrations are below the NO<sub>2</sub>, PM<sub>10</sub> and PM<sub>2.5</sub> standards. Therefore, in accordance with the EPUK & IAQM (2017) guidance, the impacts on all modelled receptors are considered **‘not significant’**.

## 5 Mitigation Measures

### 5.1 Operational

The results of the air quality assessment demonstrated that the air quality impacts are anticipated to be '**not significant.**' To note, the EPUK & IAQM (2017) guidance, which reiterates the PPG, states:

*"Mitigation options where necessary, will depend on the proposed development and should be proportionate to the likely impact."*

Therefore, on the basis that the traffic impacts are '**not significant,**' no mitigation measures are deemed necessary.

## 6 Summary & Conclusions

### 6.1 Operational Phase – Traffic Emissions

The impact assessment indicates that the impacts on human receptors associated with the DCO amendments would be **'not significant,'** and not result in any new, or materially different, likely significant effects on the environment with respect to air quality.

# Appendix A – Receptor Locations

Table A.1 – Modelled Receptor Locations

Receptor ID	Description	Coordinates (m)		
		X	Y	Z
<b>Modelled Receptor Locations</b>				
C1	M1 / Collingtree	474979	255370	1.5
C2	M1 / Collingtree	474984	255370	1.5
C3	M1 / Collingtree	474989	255371	1.5
C4	M1 / Collingtree	474994	255371	1.5
C6	M1 / Collingtree	474983	255420	1.5
C7	M1 / Collingtree	474975	255420	1.5
C8	M1 / Collingtree	474962	255428	1.5
C9	M1 / Collingtree	474955	255428	1.5
C10	M1 / Collingtree	474950	255434	1.5
C11	M1 / Collingtree	474944	255441	1.5
C12	M1 / Collingtree	474939	255446	1.5
C13	M1 / Collingtree	474921	255457	1.5
C14	M1 / Collingtree	474915	255463	1.5
C15	M1 / Collingtree	474909	255470	1.5
C16	M1 / Collingtree	474883	255479	1.5
C17	M1 / Collingtree	474895	255487	1.5
NSSUE1	M1 / Collingtree	474624	255809	1.5
NSSUE2	M1 / Collingtree	474744	255676	1.5
NSSUE3	M1 / Collingtree	474765	255660	1.5
C5	M1 / Collingtree	475030	255401	1.5
W1	A45 / Wootton	475743	255971	1.5
W2	A45 / Wootton	475853	256539	1.5
W3	A45 / Wootton	475838	256927	1.5
W4	A45 / Wootton	475799	257259	1.5
W5	A45 / Wootton	475669	257377	1.5
H1	Hartwell	479018	250957	1.5
H2	Hartwell	479123	250870	1.5
H3	Hartwell	479247	250730	1.5
H4	Hartwell	479291	250610	1.5

## Appendix B – Traffic Data

**Table B.1 – 2023 Verification Traffic Flows**

Link	Speed (Kph)	2023 Traffic Flows		
		Total Vehicles	HGV	HGV %
15	97	51553	9342	18%
16	97	58310	9902	17%
37	89	34493	2682	8%
38	88	30390	1846	6%
39	85	29794	2881	10%
40	88	27801	2418	9%
17	98	46858	10218	22%
18	98	47116	9692	21%

**Table B.2 – 2031 Baseline Traffic Flows**

Link	Speed (Kph)	2031 Traffic Flows		
		Total Vehicles	HGV	HGV %
15	97	64650	12930	20%
16	95	71071	13503	19%
37	85	29151	3498	12%
38	84	30260	3026	10%
39	76	37161	4831	13%
40	84	30260	3026	10%
17	99	61580	11700	19%
18	98	64032	12166	19%

**Table B.3 – 2031 Baseline + Proposed Development Traffic Flows**

Link	Speed (Kph)	2031 Traffic Flows		
		Total Vehicles	HGV	HGV %
15	97	64799	12982	20.03%
16	95	71262	13551	19.02%
37	85	29482	3570	12.11%
38	84	30539	3092	10.12%
39	76	37523	4903	13.07%
40	84	30536	3092	10.13%
17	99	61771	11753	19.03%
18	98	64202	12224	19.04%

## Appendix C – Background Calibration Process

**Table C.1: NO<sub>2</sub> Background Calibration for West Northamptonshire Council**

NO <sub>2</sub>	Monitoring Sites	
	Defra run AURN site - UKA00632	47, 48, 49
Measured Concentration (µg/m <sup>3</sup> )	10.0	9.3
Mapped Concentration (µg/m <sup>3</sup> )	8.4	8.4
Calibration Factor	1.19	1.10
Average Calibration Factor	1.15	

**Table C.2: PM<sub>2.5</sub> Background Calibration for West Northamptonshire Council**

PM <sub>2.5</sub>	Monitoring Site
	Defra run AURN site - UKA00632
Measured Concentration (µg/m <sup>3</sup> )	7
Mapped Concentration (µg/m <sup>3</sup> )	7.3
Calibration Factor	0.96

## Appendix D - Verification

Model verification studies are undertaken in order to check the performance of dispersion models and, where modelled concentrations are significantly different to monitored concentrations, a factor can be established by which the modelled results can be adjusted in order to improve their reliability. The model verification process is detailed in TG22.

According to TG22, no adjustment factor is necessary where the results of the model all lie within 25% of the monitored concentrations, but ideally within 10%.

### Modelled Verification: A45

The modelled road network (including the modelled road speeds), and location of the verification monitoring locations used for the verification process within WNC is demonstrated in **Figure D.1** and **Figure D.2**.

**Figure D.1: 2023 Modelled Verification Road Network (A45 and M1 Site)**

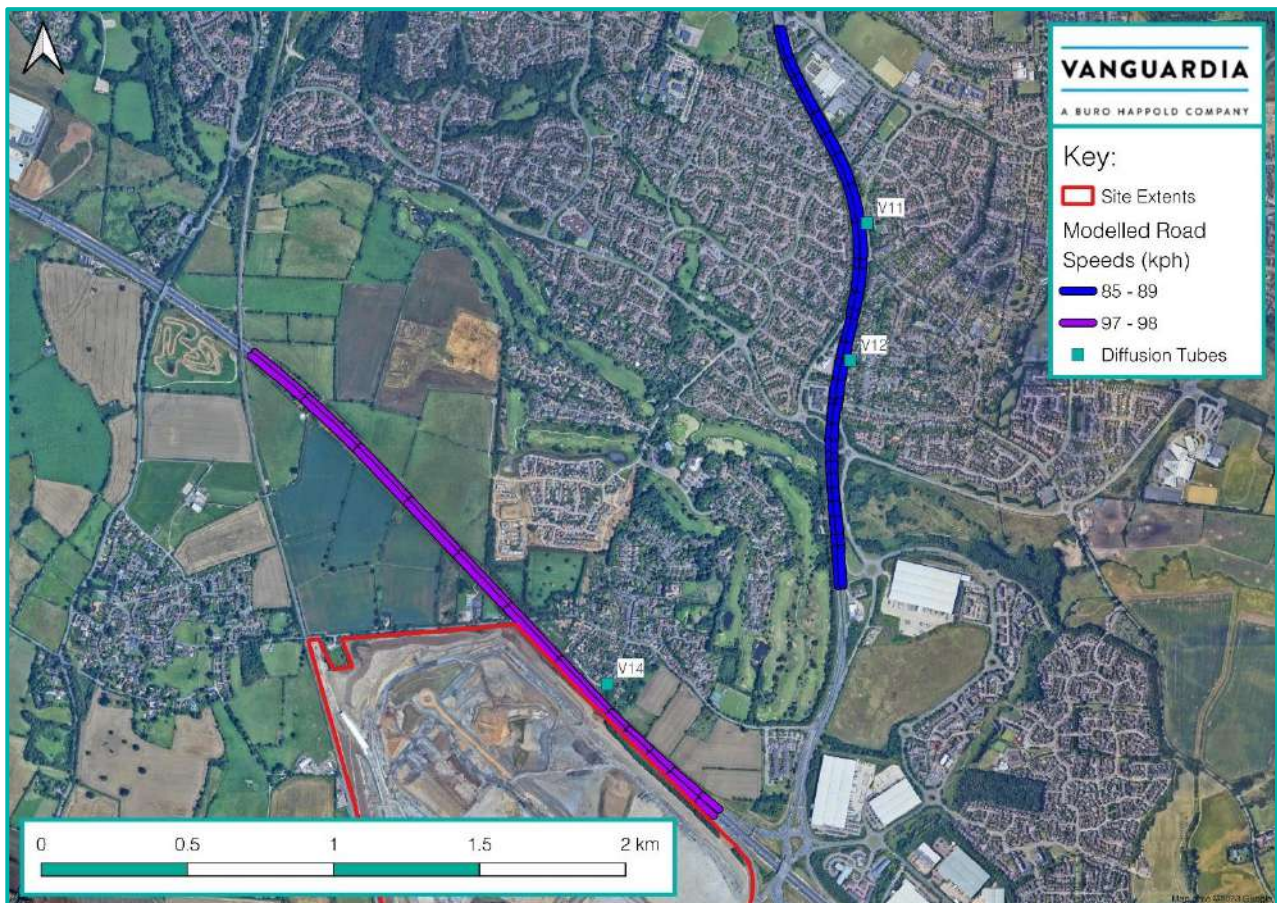

Model verification can only be undertaken where there is sufficient roadside monitoring data in the vicinity of the subject scheme being assessed. TG22 recommends that a combination of automatic and diffusion tube monitoring data is used; although this may be limited by data availability.

For this assessment in WNC, two roadside diffusion tube monitoring locations were chosen for the verification process.

## NO<sub>2</sub> Verification

**Table D.1** compares the monitored and modelled NO<sub>2</sub> concentrations at the monitoring locations.

**Table D.1: Comparison of Monitored and Modelled NO<sub>2</sub> Concentrations**

Site ID	Type	Concentrations (µg/m <sup>3</sup> )		
		Monitored	Modelled	% Difference
11	Diffusion Tube	23.4	15.7	-32.9
12	Diffusion Tube	17.7	17.0	-4.2

The data in **Table D.1** shows that the model is under-predicting NO<sub>2</sub> concentrations. This is not unusual and is likely to be the result of local dispersion conditions. Since some of the modelled results lie outside of the ideal 10% margin of error, an adjustment has been derived.

As it is primary NO<sub>x</sub> rather than secondary NO<sub>2</sub> emissions that are modelled, an adjustment factor must be derived for the road contribution of NO<sub>x</sub>. A ratio of the modelled versus monitored NO<sub>x</sub> concentrations using the least squares statistical method has been undertaken to derive an adjustment factor, as set out in **Table D.2**.

**Table D.2: Deriving the Adjustment Factor**

Site ID	Monitored Road NO <sub>x</sub> (µg/m <sup>3</sup> )	Modelled Road NO <sub>x</sub> (µg/m <sup>3</sup> )	Ratio
11	30.8	12.5	1.654
12	17.0	15.3	

**Table D.3** compares monitored and modelled NO<sub>2</sub> concentrations at the monitoring location after the adjustment factor has been applied.

**Table D.3: Comparison of Monitored and Adjusted Modelled NO<sub>2</sub> Concentrations**

Site ID	Type	Concentrations (µg/m <sup>3</sup> )		
		Monitored	Modelled	% Difference
11	Diffusion Tube	23.4	19.2	-17.8
12	Diffusion Tube	17.7	21.2	19.8

The data in **Table D.3** shows that NO<sub>2</sub> concentrations in the model improved after the adjustment factor was applied, indicating that the model is performing acceptably.

## Root Mean Square Error

A Root Mean Square Error (RMSE) has been calculated in **Table D.4** to determine the error within the calculations before Road-NO<sub>x</sub> adjustment, based upon the following calculation:

$$RMSE = \sqrt{\frac{1}{N} \sum_{i=1}^N (obs_i - Pred_i)^2}$$

**Table D.4: Root Mean Squared Error**

Site ID	Predictions	Observations	Difference
11	19.2	23.4	-4.2
12	21.2	17.7	3.5
RMSE:			3.8

The calculated RMSE is 3.8 µg/m<sup>3</sup>, which means that modelled results could be under or over predicting pollution concentrations between +/- 3.8 µg/m<sup>3</sup>. The RMSE means that modelled results are acceptable, as they are within a 10% margin of error (as advised in TG22), and therefore the modelling is deemed to be working within an ideal level of tolerance no further adjustment is required.

#### Fractional Bias

The fractional bias, as set out in **Table D.5**, has been calculated to identify if the model shows a systematic tendency to over or under-predict. The following formula has been used to calculate the fractional bias:

$$FB = \frac{(\text{Avg.Obs} - \text{Avg.Pred})}{0.5 (\text{Avg.Obs} + \text{Avg.Pred})}$$

**Table D.5: Fractional Bias**

Average Observed Values (µg/m <sup>3</sup> )	Average Predicted Values (µg/m <sup>3</sup> )	Fractional Bias
20.6	20.2	0.016

The calculated fractional bias is 0.016 which indicates that the model is slightly overpredicting. However, the fractional bias is close to the ideal value of 0, which suggests that the model is performing acceptably.

### Modelled Verification: M1

The modelled road network (including the modelled road speeds), and location of the verification monitoring location used for the verification process within WNC is demonstrated in **Figure D.1**.

Model verification can only be undertaken where there is sufficient roadside monitoring data in the vicinity of the subject scheme being assessed. TG22 recommends that a combination of automatic and diffusion tube monitoring data is used; although this may be limited by data availability.

For this assessment in WNC, one roadside diffusion tube monitoring location was chosen for the verification process.

#### NO<sub>2</sub> Verification

**Table D.6** compares the monitored and modelled NO<sub>2</sub> concentrations at this monitoring location.

**Table D.6: Comparison of Monitored and Modelled NO<sub>2</sub> Concentrations**

Site ID	Type	Concentrations (µg/m <sup>3</sup> )		
		Monitored	Modelled	% Difference
13	Diffusion Tube	16.0	14.7	-7.9

The data in **Table D.6** shows that the model is under-predicting NO<sub>2</sub> concentrations. This is not unusual and is likely to be the result of local dispersion conditions.

As it is primary NO<sub>x</sub> rather than secondary NO<sub>2</sub> emissions that are modelled, an adjustment factor must be derived for the road contribution of NO<sub>x</sub>. A ratio of the modelled versus monitored NO<sub>x</sub> concentrations using the least squares statistical method has been undertaken to derive an adjustment factor, as set out in **Table D.7**.

**Table D.7: Deriving the Adjustment Factor**

Site ID	Monitored Road NO <sub>x</sub> (µg/m <sup>3</sup> )	Modelled Road NO <sub>x</sub> (µg/m <sup>3</sup> )	Ratio
13	12.8	9.5	1.296

**Table D.8** compares monitored and modelled NO<sub>2</sub> concentrations at the monitoring location after the adjustment factor has been applied.

**Table D.8: Comparison of Monitored and Adjusted Modelled NO<sub>2</sub> Concentrations**

Site ID	Type	Concentrations (µg/m <sup>3</sup> )		
		Monitored	Modelled	% Difference
13	Diffusion Tube	16.0	16.0	-

The data in **Table D.8** shows that NO<sub>2</sub> concentrations in the model now match the monitored concentration, indicating that the model is performing acceptably.

### **Modelled Verification: M1 (Hartwell)**

The modelled road network (including the modelled road speeds), and location of the verification monitoring location used for the verification process within WNC is demonstrated in **Figure D.2**.

Figure D.2: 2023 Modelled Verification Road Network (M1 (Hartwell))

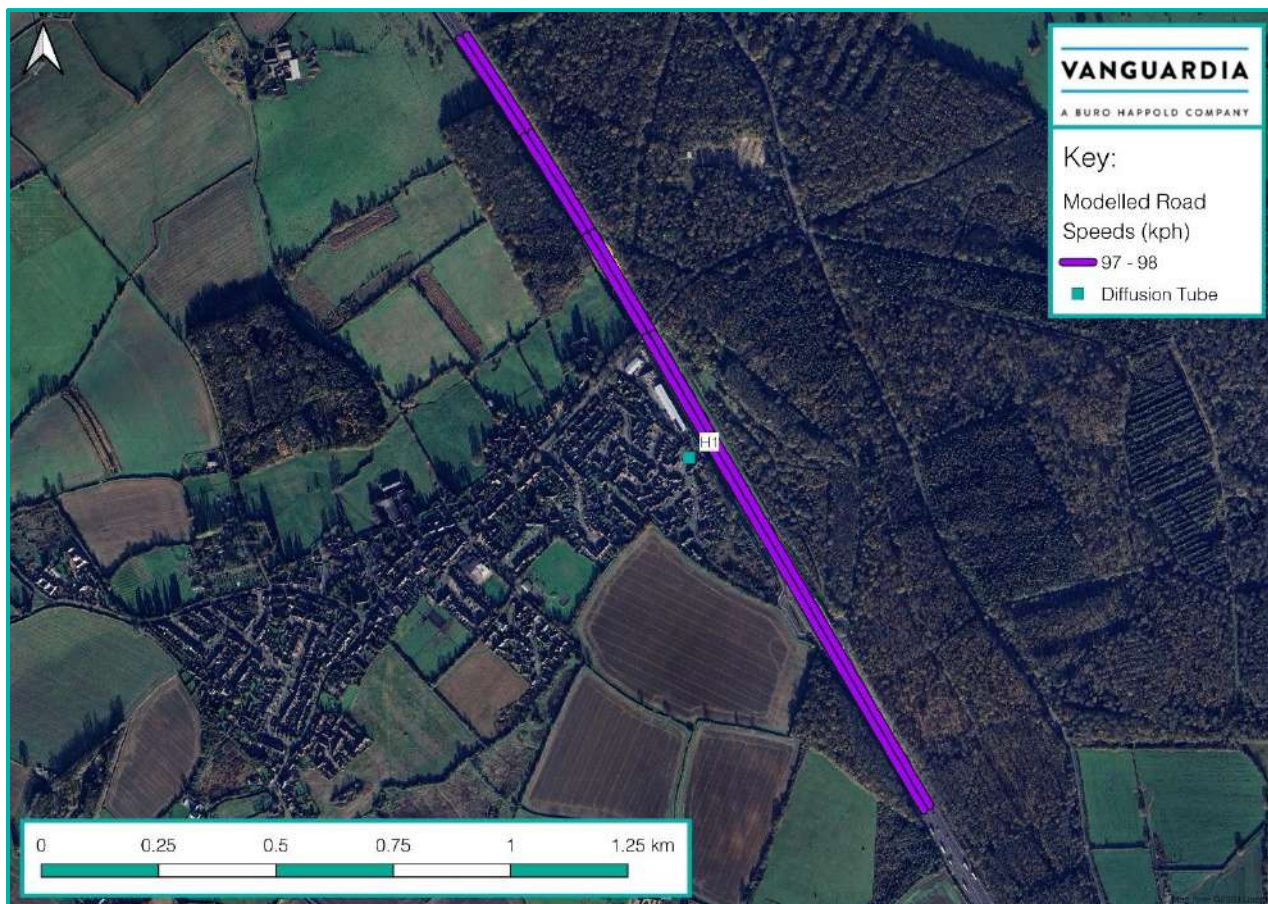

Model verification can only be undertaken where there is sufficient roadside monitoring data in the vicinity of the subject scheme being assessed. TG22 recommends that a combination of automatic and diffusion tube monitoring data is used; although this may be limited by data availability.

For this assessment in WNC, one roadside diffusion tube monitoring location was chosen for the verification process.

### NO<sub>2</sub> Verification

Table D.9 compares the monitored and modelled NO<sub>2</sub> concentrations at the monitoring location.

Table D.9: Comparison of Monitored and Modelled NO<sub>2</sub> Concentrations

Site ID	Type	Concentrations (µg/m <sup>3</sup> )		
		Monitored	Modelled	% Difference
H1	Diffusion Tube	12.4	9.4	-24.5

The data in Table D.9 shows that the model is under-predicting NO<sub>2</sub> concentrations. This is not unusual and is likely to be the result of local dispersion conditions.

As it is primary NO<sub>x</sub> rather than secondary NO<sub>2</sub> emissions that are modelled, an adjustment factor must be derived for the road contribution of NO<sub>x</sub>. A ratio of the modelled versus monitored NO<sub>x</sub> concentrations using the least squares statistical method has been undertaken to derive an adjustment factor, as set out in Table D.10.

**Table D.10: Deriving the Adjustment Factor**

Site ID	Monitored Road NO <sub>x</sub> (µg/m <sup>3</sup> )	Modelled Road NO <sub>x</sub> (µg/m <sup>3</sup> )	Ratio
H1	10.72	4.27	2.510

**Table D.11** compares monitored and modelled NO<sub>2</sub> concentrations at the monitoring location after the adjustment factor has been applied.

**Table D.11: Comparison of Monitored and Adjusted Modelled NO<sub>2</sub> Concentrations**

Site ID	Type	Concentrations (µg/m <sup>3</sup> )		
		Monitored	Modelled	% Difference
H1	Diffusion Tube	12.4	12.4	-

The data in **Table D.11** shows that NO<sub>2</sub> concentrations in the model now match the monitored concentration, indicating that the model is performing acceptably.

## Appendix E – Human Receptors Impacts

Table E.1 – 2031 Baseline + DCO Amendments: Predicted NO<sub>2</sub> Impacts at Specified Receptors – A45

Calculated NO <sub>2</sub> Annual Mean (µg/m <sup>3</sup> )				
Receptor ID	2031 Baseline	2031 Baseline + DCO Amendments	% Change of Objective	Impact Descriptor
<b>Modelled Receptors</b>				
W1	9.2	9.2	0%	Negligible
W2	10.9	10.9	0%	Negligible
W3	8.7	8.7	0%	Negligible
W4	9.8	9.8	0%	Negligible
W5	8.2	8.2	0%	Negligible
Objective - 40				

Table E.2 – 2031 Baseline + DCO Amendments: Predicted PM<sub>10</sub> Impacts at Specified Receptors – A45

Calculated PM <sub>10</sub> Annual Mean (µg/m <sup>3</sup> )				
Receptor ID	2031 Baseline	2031 Baseline + DCO Amendments	% Change of Objective	Impact Descriptor
<b>Modelled Receptors</b>				
W1	14.1	14.1	0%	Negligible
W2	15.0	15.0	0%	Negligible
W3	14.5	14.5	0%	Negligible
W4	15.6	15.6	0%	Negligible
W5	14.9	15.0	0%	Negligible
Objective - 40				

Table E.3 – 2031 Baseline + DCO Amendments: Predicted PM<sub>2.5</sub> Impacts at Specified Receptors – A45

Calculated PM <sub>2.5</sub> Annual Mean (µg/m <sup>3</sup> )				
Receptor ID	2031 Baseline	2031 Baseline + DCO Amendments	% Change of Limit	Impact Descriptor
<b>Modelled Receptors</b>				
W1	6.9	6.9	0%	Negligible
W2	7.5	7.5	0%	Negligible
W3	7.2	7.2	0%	Negligible
W4	7.7	7.8	0%	Negligible
W5	7.4	7.4	0%	Negligible
Limit – 20				

**Table E.4 – 2031 Baseline + DCO Amendments: Predicted NO<sub>2</sub> Impacts at Specified Receptors – M1 (Site)**

<b>Calculated NO<sub>2</sub> Annual Mean (µg/m<sup>3</sup>)</b>				
<b>Receptor ID</b>	<b>2031 Baseline</b>	<b>2031 Baseline + DCO Amendments</b>	<b>% Change of Objective</b>	<b>Impact Descriptor</b>
<b>Modelled Receptors</b>				
C1	12.8	12.8	0%	Negligible
C2	12.2	12.2	0%	Negligible
C3	11.6	11.6	0%	Negligible
C4	11.2	11.2	0%	Negligible
C5	9.6	9.6	0%	Negligible
C6	9.6	9.6	0%	Negligible
C7	9.9	9.9	0%	Negligible
C8	10.1	10.1	0%	Negligible
C9	10.4	10.4	0%	Negligible
C10	10.3	10.3	0%	Negligible
C11	10.3	10.3	0%	Negligible
C12	10.3	10.3	0%	Negligible
C13	10.7	10.7	0%	Negligible
C14	10.7	10.7	0%	Negligible
C15	10.7	10.7	0%	Negligible
C16	12.0	12.0	0%	Negligible
C17	10.6	10.6	0%	Negligible
NSSUE1	9.4	9.4	0%	Negligible
NSSUE2	9.6	9.6	0%	Negligible
NSSUE3	9.5	9.5	0%	Negligible
Objective - 40				

**Table E.5 – 2031 Baseline + DCO Amendments: Predicted PM<sub>10</sub> Impacts at Specified Receptors – M1 (Site)**

<b>Calculated PM<sub>10</sub> Annual Mean (µg/m<sup>3</sup>)</b>				
<b>Receptor ID</b>	<b>2031 Baseline</b>	<b>2031 Baseline + DCO Amendments</b>	<b>% Change of Objective</b>	<b>Impact Descriptor</b>
<b>Modelled Receptors</b>				
C1	16.5	16.5	0%	Negligible
C2	16.2	16.2	0%	Negligible
C3	15.9	15.9	0%	Negligible
C4	15.7	15.7	0%	Negligible
C5	14.5	14.5	0%	Negligible
C6	14.8	14.9	0%	Negligible
C7	15.0	15.0	0%	Negligible
C8	15.1	15.1	0%	Negligible
C9	15.2	15.2	0%	Negligible
C10	15.2	15.2	0%	Negligible
C11	15.2	15.2	0%	Negligible
C12	15.2	15.2	0%	Negligible
C13	15.4	15.4	0%	Negligible
C14	15.4	15.4	0%	Negligible
C15	15.4	15.4	0%	Negligible
C16	16.1	16.1	0%	Negligible
C17	15.3	15.3	0%	Negligible
NSSUE1	14.7	14.7	0%	Negligible
NSSUE2	14.8	14.8	0%	Negligible
NSSUE3	14.7	14.7	0%	Negligible
Objective - 40				

**Table E.6 – 2031 Baseline + DCO Amendments t: Predicted PM<sub>2.5</sub> Impacts at Specified Receptors – M1 (Site)**

<b>Calculated PM<sub>2.5</sub> Annual Mean (µg/m<sup>3</sup>)</b>				
<b>Receptor ID</b>	<b>2031 Baseline</b>	<b>2031 Baseline + DCO Amendments</b>	<b>% Change of Limit</b>	<b>Impact Descriptor</b>
<b>Modelled Receptors</b>				
C1	8.2	8.2	0%	Negligible
C2	8.0	8.0	0%	Negligible
C3	7.8	7.8	0%	Negligible
C4	7.7	7.7	0%	Negligible
C5	7.1	7.1	0%	Negligible
C6	7.2	7.2	0%	Negligible
C7	7.3	7.3	0%	Negligible
C8	7.3	7.3	0%	Negligible
C9	7.4	7.4	0%	Negligible
C10	7.4	7.4	0%	Negligible
C11	7.4	7.4	0%	Negligible
C12	7.4	7.4	0%	Negligible
C13	7.5	7.5	0%	Negligible
C14	7.5	7.5	0%	Negligible
C15	7.5	7.5	0%	Negligible
C16	7.9	7.9	0%	Negligible
C17	7.5	7.5	0%	Negligible
NSSUE1	7.1	7.1	0%	Negligible
NSSUE2	7.2	7.2	0%	Negligible
NSSUE3	7.1	7.1	0%	Negligible
Limit - 20				

**Table E.7 – 2031 Baseline + DCO Amendments: Predicted NO<sub>2</sub> Impacts at Specified Receptors – M1 (Hartwell)**

Calculated NO <sub>2</sub> Annual Mean (µg/m <sup>3</sup> )				
Receptor ID	2031 Baseline	2031 Baseline + DCO Amendments	% Change of Objective	Impact Descriptor
<b>Modelled Receptors</b>				
H1	7.4	7.4	0%	Negligible
H2	8.1	8.2	0%	Negligible
H3	9.9	10.0	0%	Negligible
H4	8.7	8.7	0%	Negligible
Objective - 40				

**Table E.8 – 2031 Baseline + DCO Amendments: Predicted PM<sub>10</sub> Impacts at Specified Receptors – M1 (Hartwell)**

Calculated PM <sub>10</sub> Annual Mean (µg/m <sup>3</sup> )				
Receptor ID	2031 Baseline	2031 Baseline + DCO Amendments	% Change of Objective	Impact Descriptor
<b>Modelled Receptors</b>				
H1	13.6	13.6	0%	Negligible
H2	13.9	13.9	0%	Negligible
H3	14.7	14.7	0%	Negligible
H4	14.1	14.1	0%	Negligible
Objective - 40				

**Table E.9 – 2031 Baseline + DCO Amendments: Predicted PM<sub>2.5</sub> Impacts at Specified Receptors – M1 (Hartwell)**

Calculated PM <sub>2.5</sub> Annual Mean (µg/m <sup>3</sup> )				
Receptor ID	2031 Baseline	2031 Baseline + DCO Amendments	% Change of Limit	Impact Descriptor
<b>Modelled Receptors</b>				
H1	6.5	6.5	0%	Negligible
H2	6.7	6.7	0%	Negligible
H3	7.2	7.2	0%	Negligible
H4	6.8	6.9	0%	Negligible
Limit - 20				

Vanguardia Limited

The Ministry  
79-81 Borough Road  
London SE1 1DN  
T. +44 (0) 2039 682 460

21 Station Road West  
Oxted. Surrey  
RH8 9EE  
T +44 (0) 1883 718 690

2nd Floor Eastgate  
2 Castle Street  
Castlefield  
Manchester M3 4LZ  
T +44(0) 161 233 5000